

# XT550

## Outdoor/In-Ground Speaker

Technical Information for System Engineers



**SOUNDTUBE**  
ENTERTAINMENT



### Specifications: XT550

System Type	5.25" Coax outdoor (32 Watt transformer for 25/70.7/100 Volt or voice coil/8 Ohm direct)
Frequency Response (-3 dB) <sup>1</sup>	75 Hz - 12 kHz port open (101 Hz - 12 kHz port closed)
Low Frequency (-10 dB) <sup>1</sup>	62 Hz - 22 kHz port open (62 Hz - 22 kHz port closed)
Max. Program Power	120 Watts
Max. Continuous Power RMS <sup>2</sup>	60 Watts
Max. SPL dB @ 1 M	107.5 dB
Sensitivity dB @ 1W/1M <sup>3</sup>	88.5 dB
Impedance (nominal)	4 Ohms (nominal)
Coverage Angle (-6 dB @ 2 kHz)	360° Horizontal - 40° Vertical
Coverage Angle (-6 dB @ 10 kHz)	360° Horizontal - 40° Vertical
Tap Selector	5-Position rotary switch with voice coil direct (4 Ohm)

#### Transformer Taps

70.7 V	Output	100 V	Output	25 V	Output
32 W	103.5 dB	32 W	103.5 dB	4 W	94.5 dB
16 W	100.5 dB	16 W	100.5 dB	2 W	91.5 dB
8 W	97.5 dB	8 W	97.5 dB	1 W	88.5 dB
4 W	94.5 dB			0.5 W	85.5 dB

Transducers	
Low-Frequency Driver	1 x 133 mm (5.25 in) Polypropylene cone, butyl rubber surround
High-Frequency Driver	1 x 25 mm (1.0 in) Aluminum dome
Low-Frequency Voice Coil	25 mm (1.0 in)
Network Type	
Low Pass	6 dB per octave, 1st order
High Pass	6 dB per octave, 1st order
Crossover Frequency	3.0 kHz
Enclosure Material	Roto-molded polyethylene plastic
Grille	Stainless-steel with powder-coat finish
Inputs	18-Gauge wire lead
Color Options	Granite green or sandstone
Diameter	358 mm / 14.1 in
Total Height	394 mm / 15.51 in
Weight	5.9 kG / 13.0 lbs
Shipping Weight	8.6 kG / 19.0 lbs
Accessories	
Included	Anti-theft brackets, water-tight strain relief
Optional	N/A
Packaging	1 Per box

<sup>1</sup> Frequency response is measured in half space.

<sup>2</sup> Continuous power rating, EIA-426-B test.

<sup>3</sup> 2.83 Volts at a distance of 1 meter.

SoundTube continually develops new product innovations and improvements. Updates to existing products without prior notice are an example of SoundTube's drive for constant improvement.

### Key Features

- UV-, scratch- and weather-resistant with professional-grade components for long-lasting performance and durability.
- Patented BroadBeam® waveguide technology provides smooth 360° horizontal off-axis coverage and reduces overall system costs.
- One 133 mm (5.25 in) weatherproof polypropylene woofer with butyl rubber surround and one 25 mm (1.0 in) aluminum dome tweeter with integrated horn & mounting bracket.
- Weather-proof 5-position tap switch for 25/70.7/100 Volt applications with voice coil direct (4 Ohm) position. 32 Watt transformer included
- Patented, durable and sealed Zero Reflection™ enclosure with optional port vent for added frequency response.
- Liquid-tight compression fittings for water-tight protection.
- Multiple wire inlet locations for fast and easy daisy chaining.
- Stainless steel fasteners, stainless steel & powder-coated grille.
- Color options: granite green or sandstone.

### Description

The SoundTube XT550 is a premium 2-way outdoor loudspeaker solution for installations requiring high-performance sound in a durable speaker design. The XT550 is designed for full-range background/foreground music and paging. The sealed, in-ground enclosure design delivers true low end response (62 Hz, -10 dB) and optimal off axis performance. The XT550 includes theft-resistant mounting hardware and a weather-proof 5-position tap switch for 25/70.7/100 Volt applications with voice coil direct (4 Ohm) position.

### Applications

The ultra-wide 360° horizontal dispersion pattern makes the XT550 an ideal choice for theme parks, promenades, playgrounds, shopping malls, restaurants, resorts, gardens and other outdoor applications. XT550 speakers come with in-ground anti-theft brackets and stainless-steel square-tip screws for increased outdoor security.



### Frequency Response (open/closed port)

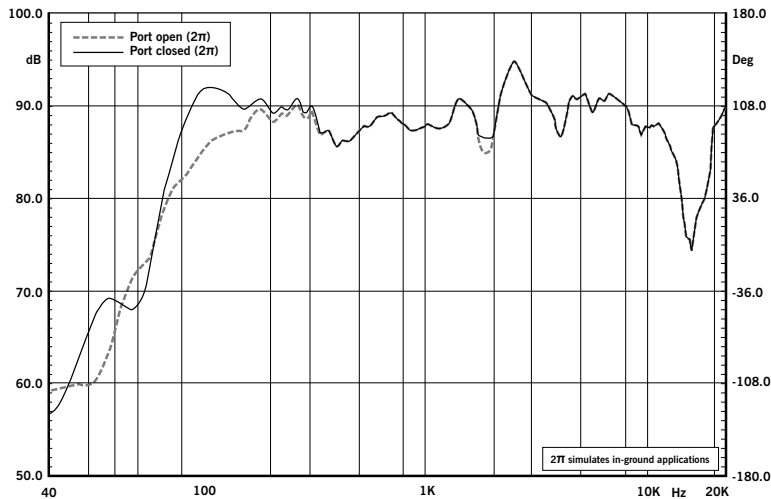

### Phase/Impedance Reponse (open port)

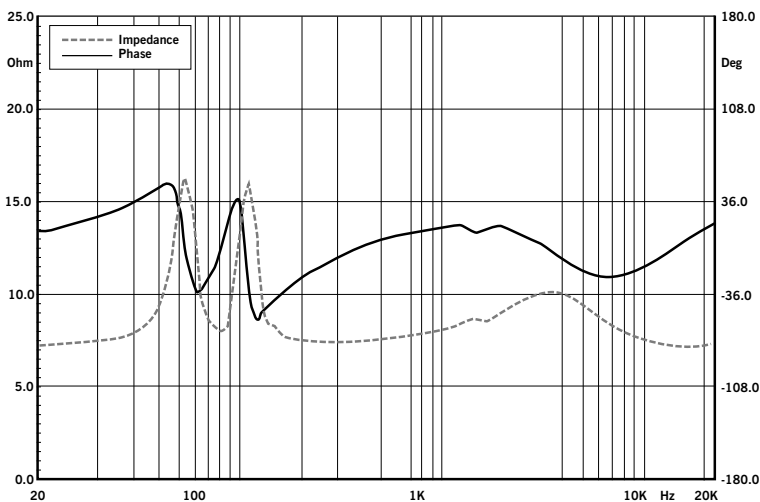

### Phase/Impedance Reponse (closed port)

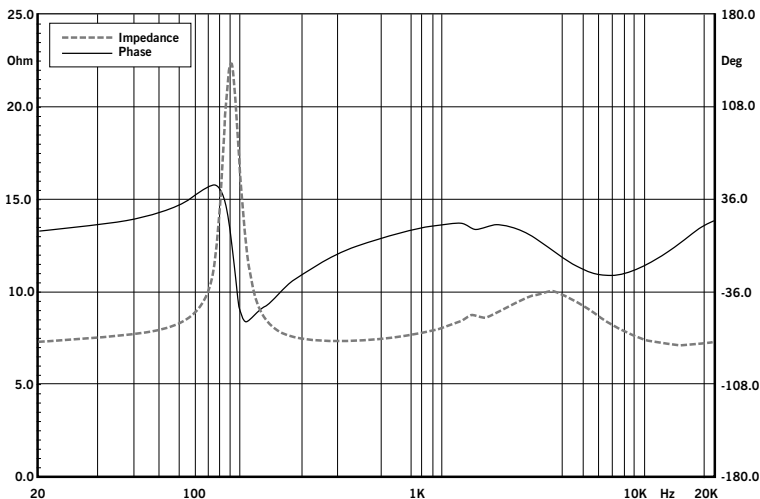

### Reduce Overall System Costs

SoundTube's BroadBeam® dispersion technology utilizes an advanced diffuser/tweeter system to provide maximum dispersion of the higher frequencies throughout the XT550's 360° horizontal by 40° vertical coverage pattern.

Designed specifically for outdoor music & paging, the XT550 projects even coverage and smooth response over a larger area than typical outdoor speakers, with fewer units per install – saving time and money on speakers, installation and amplifier power.

### Enclosure Technology

XT enclosures are engineered for maximum durability and performance. Unlike other outdoor speakers, SoundTube incorporates patented ZeroReflection™ internal shaping to create the most effective environment for sound reproduction. The result is accurate sound and tight bass in an indestructible enclosure.

### Patented SoundTube Technologies

SoundTube Entertainment is constantly developing new technologies that enhance audio product performance. SoundTube Entertainment innovations are protected by multiple U.S. & international patents, which explicitly cover SoundTube dispersion, enclosure & dome technologies. SoundTube Entertainment actively defends its patents in order to protect SoundTube resellers and end users.

### Technical Data and Specification Tools

#### Technical Data

SoundTube Entertainment strives to provide complete and effective technical information and data to dealers, engineers and designers. All data are available from SoundTube Entertainment or at [www.soundtube.com](http://www.soundtube.com)

#### Data Acquisition

All performance data acquired at SoundTube's Technical Measurement Center (TMC) are analyzed using a variety of standard measurement techniques, including Measured Length Sequence (MLS) and Time Delay Spectrometry (TDS). Performance, development and data acquisition tools include: Gold Line TEF 20, CLIO, LMS, LEAP, and proprietary modeling software. EASE™ data are acquired through an automated TEF20/Outline/EASE™ interface.



### Mechanical Drawings

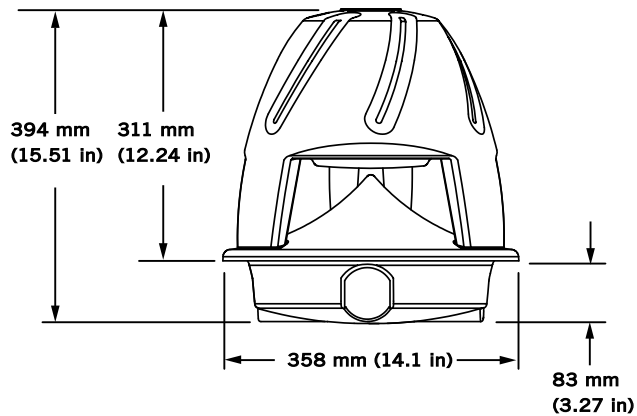

### Included Accessory

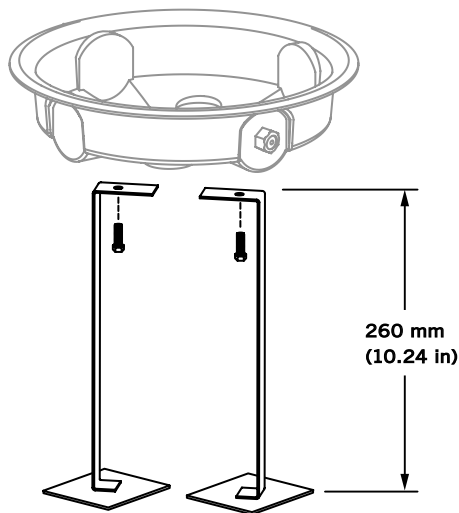

### Anti-theft hardware

### Architectural Specifications

The loudspeaker shall be an in-ground design consisting of one 133 mm (5.25 in) low-frequency transducer and one 25 mm (1.0 in) aluminum dome high-frequency transducer with a frequency-dividing network installed in an optionally sealed enclosure. The low-frequency voice coil diameter shall be 25 mm (1.0 in).

Performance specifications of a typical production unit shall be as follows: Usable frequency response shall extend from 62 Hz – 22 kHz (-10 dB). Measured sensitivity (2.83 Volt input, 1 meter) shall be at least 88.5 dB. The maximum continuous output at 1 meter shall be 107.5 dB. Rated power capacity of the components and network shall be at least 60 Watts continuous RMS power. The loudspeaker shall have a nominal impedance of 4 Ohms and be available for 25/70.7/100 Volt modes with voice coil/4 Ohm direct. The frequency-dividing network shall have a crossover frequency of 3.0 kHz.

The enclosure shall be constructed of a rotomolded polyethylene plastic and have a removable port plug constructed of buna-N rubber. The grille shall be constructed of powder-coated stainless-steel. Color options shall be granite green or sandstone. All transducers and network circuitry are weather resistant and ship in a sealed enclosure.

Installation shall be by in-ground mount. The external wiring input connector shall be hard-wire leads. The overall cabinet dimensions shall be no more than 358 mm (14.1 in) in diameter by 394 mm (15.51 in) in height and shall weigh no more than 5.9 kG (13.0 lbs).

The low-frequency transducer shall have a weatherproof butyl rubber surround to resist weather, elements and insects. The high-frequency transducer shall be a horn-loaded dome and constructed of aluminum.

For theft deterrence, all XT550 speakers come with anti-theft brackets and square-tip screws.

The system shall be the XT550 for both low and high impedance applications.

### SoundTube Entertainment

6430 North Business Park Loop  
Park City, Utah 84098  
Phone 435.647.9555  
Fax 435.647.9666  
Toll Free 800.647.TUBE  
www.soundtube.com

**All SoundTube products come with a 5-year limited warranty.**