

Maximum power, minimum size

H-compact

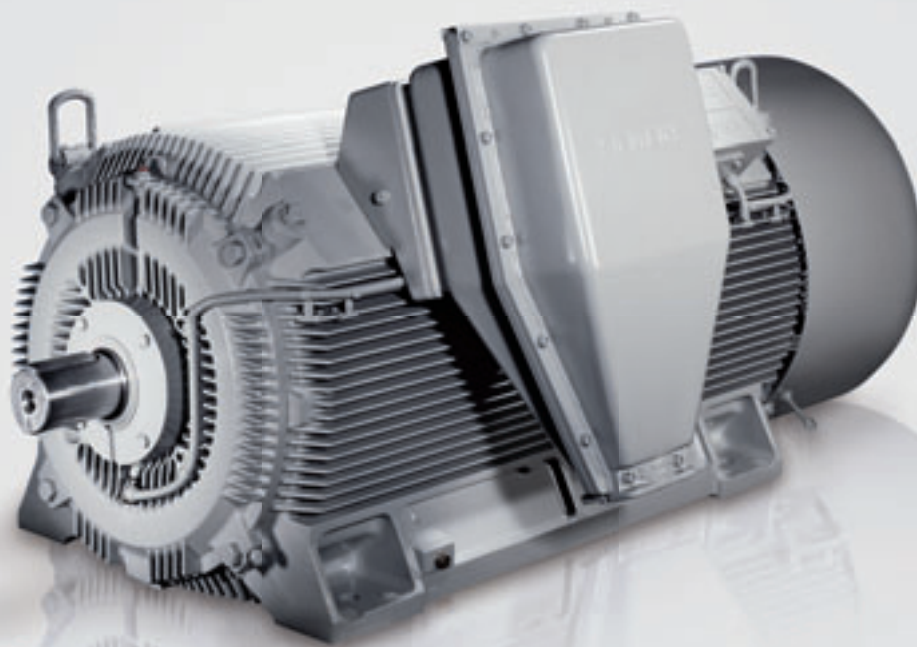

Motors

Answers for industry.

SIEMENS

Great performers in even the tightest space – latest generation of high-voltage motors.

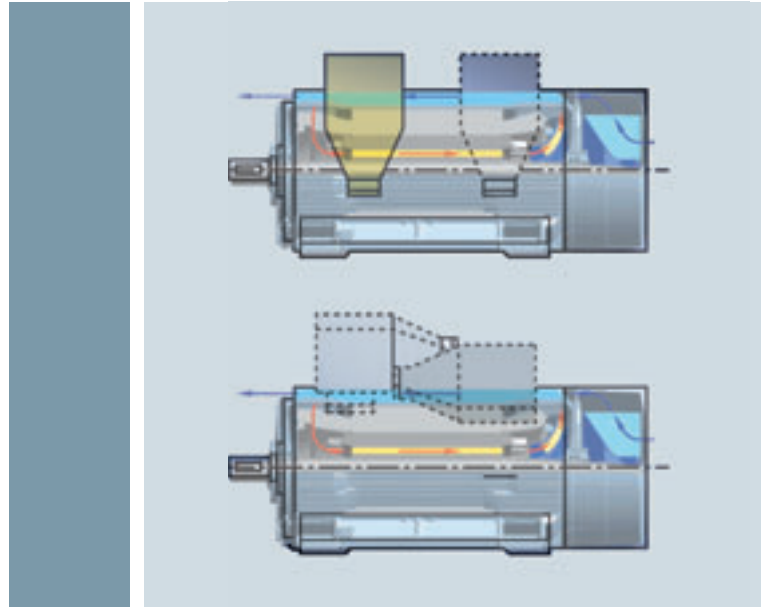

Space costs money in industry. When designing our H-compact high-voltage motors, this is the reason that we have consciously kept the envelope dimensions as low as possible – without having a negative impact on the performance.

You are right in expecting that your drive system operates reliably – but without taking up unnecessary, valuable space. We have especially focused on achieving the highest degree of reliability and lowest envelope dimensions. The result of our development work: H-compact, the high-voltage motor that admirably fulfills both of these requirements: reliable power and compact design.

Different versions available

We supply H-compact in versions for direct online operation, for drive converter operation and for use in hazardous zones.

Horizontal

Standard motors with type of construction IM B3 – on request other types of construction are available, for example IM B35.

Vertical

IM V1 with protective roof assembly.
IM V1 without protective roof assembly.

Degrees of protection IP55 and higher.

Cooling type IC411 or IC416.

Perfect cooling for a long lifetime

The extremely low envelope dimensions of the H-compact have been achieved by using a highly efficient two-circuit cooling system.



With the longest lifetime and highest reliability.



Open rolling-contact bearing



Open flanged-mounted sleeve bearings with lubrication

For many years now, H-compact stands for the highest degree of quality and ruggedness.

When developing the new series, we again placed topmost priority on these features – as you have come to expect from Siemens. The results: maximum reliability and long lifetime.



For instance, the frame and end shields are ribbed and manufactured out of gray cast iron with a sophisticated aerodynamic shape. The frame tapers in at some locations in order to optimize the cooling airflow. The motors have a high degree of strength and stiffness thanks to the internal ribs in the area around the stator winding overhang as well as the box-section feet along the complete length. The gray cast-iron frame in conjunction with high-quality anti-corrosion protection and paint finish protect the motors against the effects of the weather over many years. The innovative two-circuit cooling concept not only permits a high power density, but also ensures that the temperature is uniformly distributed in the motor: one of our measures to guarantee you the highest reliability! H-compact motors are generally equipped with rolling-contact bearings. For higher

speed, load capability and operating conditions, we can also equip our motors with sleeve bearings. Flange-type sleeve bearings are used and are suitable for both clockwise and counter-clockwise rotation without having to make any changes. Depending on the bearing load, they have an oil-ring lubrication system with natural cooling either through radiation or convection or a circulating-oil lubricating system with oil cooling. It is possible to retrofit motors with a circulating-oil system at any time without having to make any modifications.

The drive end and non-drive end bearings are floating bearings. The maximum axial play is ± 3.5 mm. In this case, the motor rotor and the mechanical transmission line must be axially located using a limited-end-float coupling at the driven load.

Technology that has proven itself.



The Siemens MICALASTIC® insulating system, proven worldwide and used for high-rating high-voltage motors, is also used in the H-compact. This means that your motors have an insulation which is absolutely world class when it comes to reliability and long lifetime.



High starting torques

Take full advantage of the high starting torques. An additional benefit which distinguishes H-compact. This guarantees faster starting even for high load torques and external moments of inertia. The high locked rotor time provides you with an even higher degree of security if the rotor is externally locked.

Continuous monitoring

Even the most sophisticated motor can be subject to operational conditions for which it was not originally designed. Sensors and monitoring devices can continually sense the electrical, thermal and mechanical operating data. Six PT 100 slot resistance thermometers and surge pulse measuring nipples (SPM) for rolling-contact bearings are provided as standard.

Well-proven MICALASTIC VPI insulation

For many decades now the Siemens MICALASTIC® insulating system has proven itself worldwide. The VPI technique (Vacuum Pressure Impregnation), harmonized with the insulation design, is an important element of the MICALASTIC insulation system. This technique guarantees that the insulation is almost free of any voids, therefore providing favorable partial discharge characteristics. A good thermal transition between the winding and laminated core is guaranteed. The long electrical lifetime is achieved, among other things, by using a high percentage of mica in the insulation. In conjunction with the high mechanical strength and thermal endurance, these factors ensure an extremely high winding lifetime – even under tough ambient conditions.

Reliable and rugged

In the lower power range, H-compact motors are equipped with aluminum die-cast rotors. Copper cage windings are optionally available. Both of these versions provide excellent performance. The aluminum die-cast technology has the additional benefit of being extremely rugged due to the form-fit connection between the rotor bars and laminated core.

Low noise and good cooling.

Safety at work is becoming increasingly important. The new series of H-compact motors is especially quiet. We optimized both the fan assembly as well as the frame to achieve even better acoustic properties – and less noise. Hear for yourself. The appropriate safety at work regulations are generally maintained without having to apply costly and complex noise-reducing measures.

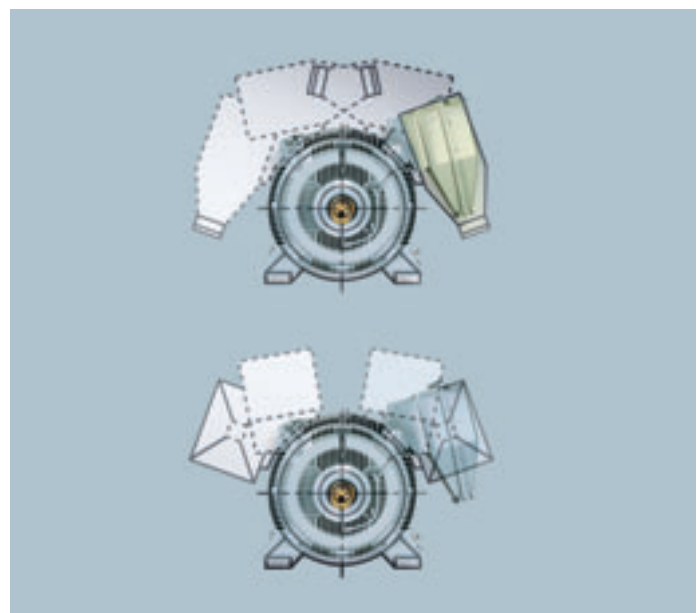

Innovative cooling

Effective cooling is a decisive factor for high-voltage motors. Good heat dissipation allows a high power density to be reached. An additional goal is to achieve a uniform temperature level. This reduces the thermal load on the motor components (e. g. winding and bearings) thus increasing the lifetime and reliability of your motor.

The Siemens two-circuit cooling system

Siemens high-voltage motors have surface as well as inner cooling. The frame acts as a heat exchanger between the internal and external air. The frame has been aerodynamically optimized to guide the external cooling airflow. This is the

reason that it has a tapered shape which ensures that there is an optimum contact between the cooling airflow and the frame. The internal cooling airflow circuit has been harmonized with the characteristics of the closed motor. The rotor has cooling air ducts through which the internal fan, located at the non-drive end, draws in air. This cooling air is subject to high turbulence at the internal ribs of the frame and the end shield ribs which means that it is intensively cooled down. Air in the motor flows through four air ducts in the frame, in the same direction as the outer airflow, to the drive end. This codirectional principle ensures uniform cooling and low bearing and winding temperatures at the drive end.

Harmonized system solutions for variable-speed operation.

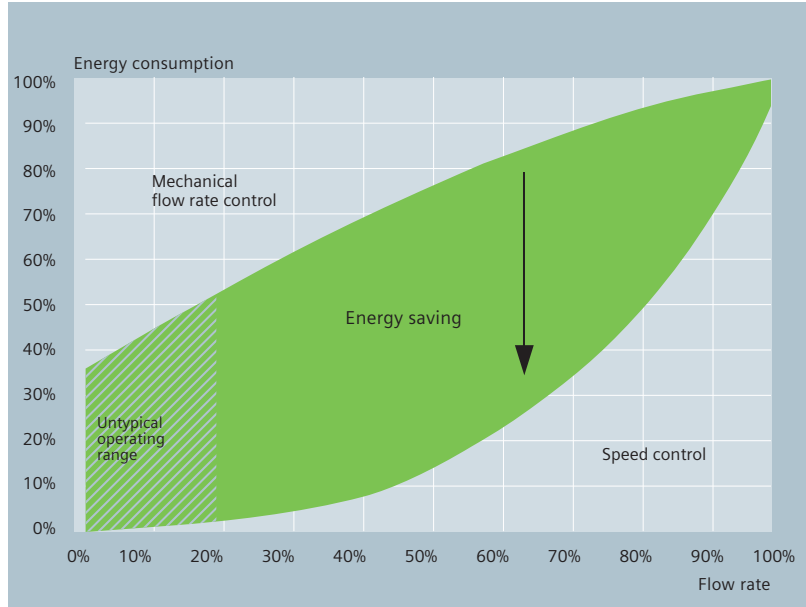

System solutions with a high degree of availability and efficiency can be implemented by combining H-compact with the frequency converter families: ROBICON Perfect Harmony for medium voltage and SINAMICS for medium and low voltage.

Lower energy consumption

Drive converters allow large amounts of energy to be saved – up to 60%, in extreme cases even up to 70% – as the drive power can be flexibly adapted to the requirements of the plant or system. This is because pumps, fans and compressors are frequently operated in the partial load range. For fixed-speed drives the material flow must, for example, be reduced using a throttle valve. This means that without flexible speed control a high proportion of the drive power is unused. And today, who can tolerate such a waste?

More precise processes have a short payback time

In many cases, AC drive converters allow processes to be controlled more precisely. Soft starting and stopping using continuous speed control reduces the stress on the mechanical system. This reduces your operating costs and plays a role in reducing payback times.

With local service.
We are there for you.



Select the right motor – and the right partner. With Siemens, you are in better shape from the word go. We are one of the leading electrical and electronic engineering companies in the world and we are there for you in 130 countries and 450 cities. Our employees can optimally support you locally – wherever you are. From the initial help to create the optimum motor concept up to reliable support for maintenance, troubleshooting and much more. With Siemens, everything runs smoothly – and you always have somebody you can personally talk to. Simply ask us – we will take care of the rest.

Our Hotline: +49 (0) 180 / 505 02 22

We offer far more than technology ...

We will flexibly address your individual requirements. This is all made possible by our logistics and production control system.

... and high-quality components and materials

We carefully select our suppliers. For us, quality checks and assurance means a qualified incoming goods process. Further, we have sophisticated production monitoring procedures so that we can quickly intervene where necessary. Our final check ensures that only perfect products leave our factories. When so requested, we can also fulfill specific customer test criteria.

H-compact: Technical data and dimensions

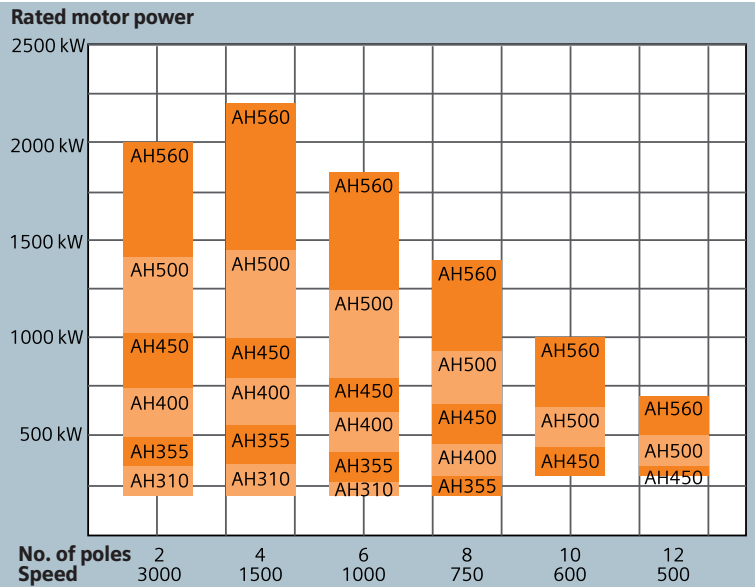

From Siemens you can obtain a wide range of types extensively and finely graduated. Our motors have been designed for rated voltages from 2 to 11 kV (as low-voltage system also with 690 V) as well as rated frequencies of 50 and 60 Hz.

Motors with pole numbers of between 2 and 12 are available as standard. H-compact is suitable for use in Zone 2 (non-sparking). Versions with degree of protection EEx e "increased safety" and EEX pe "pressurized" are listed in the catalog for Zone 1.

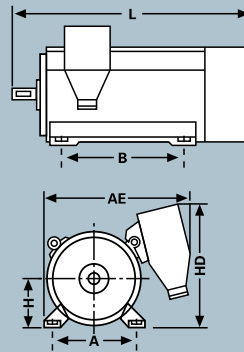

Maximum dimensions in mm
for rolling-contact bearing versions for 6 kV

H	HD	AE	L	A	B
310	860	1,075	1,785	610	900
355	930	1,155	1,925	686	1,000
400	1,010	1,255	2,090	750	1,120
450	1,100	1,340	2,390	850	1,250
500	1,200	1,440	2,525	950	1,320
560	1,310	1,560	2,775	1,060	1,400

Siemens AG
Industry Sector
Large Drives
P. O. Box 47 43
90025 NÜRNBERG
GERMANY

www.siemens.com/h-compact

Subject to change without prior notice
Order No.: E20001-A180-P530-X-7600
DISPO 21503
21/15416 MK.LD.XX.LDHM.52.8.04 WS 08085.
Printed in Germany
© Siemens AG 2008

The information provided in this brochure contains merely general descriptions or characteristics of performance which in actual case of use do not always apply as described or which may change as a result of further development of the products. An obligation to provide the respective characteristics shall only exist if expressly agreed in the terms of contract.

All product designations may be trademarks or product names of Siemens AG or supplier companies whose use by third parties for their own purposes could violate the rights of the owners.