

# High-Voltage Motors H-compact **Standardline** Operation on supply system

# 4



<b>4/2</b>	<b>Overview</b>
<b>4/2</b>	<b>Benefits</b>
<b>4/2</b>	<b>Technical specifications</b>
<b>4/3</b>	<b>Selection and Ordering Data</b>
<b>4/7</b>	<b>Options</b>
<b>4/8</b>	<b>Dimensional drawings</b>
<b>4/9</b>	<b>More information</b>
4/9	Description - construction details
4/9	Housing, cooling system
4/9	Hoisting gear
4/9	Rotor construction
4/9	Shaft
4/9	Direction of rotation, fans and fan shroud
4/9	Vibration response
4/9	Insulation system
4/9	Noise
4/9	Switching frequency
4/10	Connection box
4/10	Auxiliary connection box
4/10	Paint finish
4/10	Bearing construction



# High-Voltage Motors H-compact Standardline

## Operation on supply system

### Overview



H-compact Standardline is a range of standardized, rib-cooled high-voltage motors incorporating the latest state-of-the-art technology.

Their appeal lies in their excellent reliability, durability and robust design.

The following versions of H-compact Standardline motors are available:

- Power range 200 to 800 kW
- Supply voltages 3 / 3.3 / 6 and 6.6 kV, 50 Hz
- 2-pole, 4-pole and 6-pole
- Type of construction IM B3

### Benefits

The focus on a design which is standardized, but capable of satisfying a wide range of applications, has made it possible to optimize production processes and consequently slash delivery times and the price at which high-voltage motors are supplied.

Benefits to the customer:

- State-of-the-art motor technology which is already in use worldwide
- Attractive price
- Quick delivery time of only 6 weeks
- Maximum power density
- Low operating costs thanks to excellent efficiency
- High output combined with small dimensions makes it possible to build extremely compact units

### Technical specifications

Type of construction	IM B3 (IM 1001)
Shaft heights	315 mm, 355 mm, 400 mm
Type of protection	IP55
Cooling method	IC 411; ribbed cooling, self-ventilated, with additional inner cooling circuit
Ambient conditions	Max. ambient temperature (cooling medium temp.) CT = 40 °C Installation altitude ≤1000 m above sea level. Ambient temperatures up to 55 °C possible with utilization according to temperature class F. Operation and starting permissible at temperatures down to -20 °C.
Insulation system	MICALASTIC® with Vacuum Pressure Impregnation (VPI)
Rotor construction	with aluminum die-cast cage
Bearing construction	Deep-groove ball bearing to DIN 625, with SPM nipple (shock pulse measurement)
Bearing box and shields	Made of grey cast iron, integrally cast motor feet
Temperature monitoring	By 6 PT 100s in stator winding as standard (not included if PTC thermistors are ordered)
Auxiliary connection box	standard feature
Regulations and standards	in accordance with IEC 60034-1 ff.

### Selection and Ordering Data

Note:

Motors are available only with the specified data for voltage, frequency and output.

The documentation supplied is standardized. It contains starting characteristics for  $V_{rated}$  and 80 %  $V_{rated}$  without load torque. A starting inspection is not included.

Rated output 1)	Order No. + order codes for further options	Operating values at rated output						Starting torque	Starting current	Stalling torque	Moment of inertia J		Sound pressure level 2)		
		Rated speed	Efficiency $\eta$ with		Power factor $\cos \varphi$	Rated current	Rated torque				with direct starting as multiple of rated			Motor	External max. perm.
			4/4 load	3/4 load							torque	current			
kW		rpm	%	%	A	Nm							dB(A)		
<b>3 kV, 50 Hz</b>															
<b>3000 rpm, 2-pole</b>															
200	1LA4310-2AN30-Z + B20	2970	95.2	95.2	0.87	46.0	643	0.90	5.05	2.3	2.2	28	73/74		
236	1LA4312-2AN30-Z + B20	2967	95.0	95.2	0.87	55.0	759	0.90	5.00	2.3	2.2	26	73/74		
300	1LA4314-2AN30-Z + B20	2972	95.7	95.8	0.88	69.0	964	1.05	5.20	2.4	2.7	30	73/74		
355	1LA4316-2AN30-Z + B20	2974	96.2	96.2	0.88	81.0	1140	1.10	5.30	2.5	3.1	35	73/74		
400	1LA4350-2AN30-Z + B20	2978	96.1	96.2	0.88	91.0	1283	1.05	5.25	2.3	4.3	38	75/76		
450	1LA4352-2AN30-Z + B20	2978	96.4	96.4	0.88	102.0	1443	1.20	5.55	2.5	4.8	43	75/76		
500	1LA4354-2AN30-Z + B20	2980	96.6	96.7	0.88	114.0	1602	1.20	5.55	2.5	5.2	46	75/76		
560	1LA4400-2AN30-Z + B20	2984	96.5	96.4	0.88	128.0	1792	0.85	5.40	2.5	7.8	26	77/78		
650	1LA4402-2AN30-Z + B20	2985	96.8	96.7	0.88	146.0	2079	0.90	5.60	2.6	8.7	27	77/78		
750	1LA4404-2AN30-Z + B20	2985	96.7	96.7	0.89	168.5	2398	0.95	5.60	2.6	9.9	30	77/78		
<b>1500 rpm, 4-pole</b>															
200	1LA4310-4AN30-Z + B20	1480	94.3	94.4	0.81	50.0	1290	1.15	5.20	2.30	2.8	159	75/77		
250	1LA4312-4AN30-Z + B20	1480	95.0	95.2	0.84	60.0	1613	1.15	5.30	2.30	3.5	201	75/77		
300	1LA4314-4AN30-Z + B20	1480	95.2	95.4	0.85	72.0	1936	1.25	5.50	2.40	4.0	222	75/77		
365	1LA4316-4AN30-Z + B20	1481	95.7	95.9	0.85	87.0	2353	1.25	5.50	2.40	4.8	297	75/77		
400	1LA4350-4AN30-Z + B20	1485	95.7	95.8	0.84	96.0	2572	1.25	5.50	2.50	6.0	224	77/79		
470	1LA4352-4AN30-Z + B20	1484	95.9	96.0	0.85	110.0	3024	1.20	5.30	2.35	6.9	247	77/79		
560	1LA4354-4AN30-Z + B20	1485	96.2	96.3	0.86	130.0	3601	1.30	5.50	2.40	8.1	296	77/79		
630	1LA4400-4AN30-Z + B20	1488	96.3	96.3	0.85	148.0	4043	1.20	5.50	2.50	11.6	288	79/81		
710	1LA4402-4AN30-Z + B20	1488	96.5	96.5	0.85	166.0	4556	1.20	5.50	2.50	12.9	330	79/81		
800	1LA4404-4AN30-Z + B20	1488	96.6	96.6	0.86	186.0	5134	1.20	5.50	2.50	14.5	381	79/81		
<b>1000 rpm, 6-pole</b>															
236	1LA4314-6AN30-Z + B20	986	94.6	94.9	0.82	59.0	2286	1.25	5.30	2.50	5.3	375	69/72		
270	1LA4316-6AN30-Z + B20	985	94.8	95.2	0.82	66.0	2617	1.25	5.50	2.40	6.4	431	69/72		
315	1LA4350-6AN30-Z + B20	989	95.3	95.5	0.82	78.0	3042	1.10	5.30	2.30	10.8	541	71/74		
365	1LA4352-6AN30-Z + B20	989	95.6	95.8	0.83	89.0	3523	1.10	5.30	2.20	12.7	667	71/74		
425	1LA4354-6AN30-Z + B20	990	95.8	95.9	0.82	104.0	4099	1.25	5.50	2.40	15.0	841	71/74		
490	1LA4400-6AN30-Z + B20	991	95.9	96.0	0.81	118.0	4722	1.05	5.50	2.30	21.2	740	73/76		
570	1LA4402-6AN30-Z + B20	992	96.2	96.3	0.81	136.0	5487	1.10	5.50	2.30	24.2	1193	73/76		
630	1LA4404-6AN30-Z + B20	991	96.3	96.3	0.80	154.0	6071	1.20	5.50	2.40	27.3	1233	73/76		

1) Temperature class F, utilization in accordance with B.

2) Measured at distance of 1 m in accordance with DIN 45635 (Part 1), tolerance +3 dB(A).

# High-Voltage Motors H-compact Standardline

## Operation on supply system

Rated output 1)  kW	Order No. + order codes for further options	Operating values at rated output						Starting torque	Starting current	Stalling torque	Moment of inertia J		Sound pressure level 2)  dB(A)			
		Rated speed	Efficiency $\eta$ with		Power factor $\cos \varphi$	Rated current	Rated torque				with direct starting as multiple of rated			Motor	External max. perm.	
			4/4 load	3/4 load							torque	current				torque
		rpm	%	%	A	Nm										
<b>3.3 kV, 50 Hz</b>																
<b>3000 rpm, 2-pole</b>																
200	1LA4310-2AN00-Z + B20	2977	95.5	95.2	0.85	43.0	641	1.10	6.00	2.85	2.2	28	73/74			
236	1LA4312-2AN00-Z + B20	2975	95.2	95.2	0.84	52.0	757	1.10	5.90	2.80	2.2	26	73/74			
300	1LA4314-2AN00-Z + B20	2978	95.9	95.7	0.85	65.0	962	1.30	6.15	2.95	2.7	30	73/74			
355	1LA4316-2AN00-Z + B20	2980	96.3	96.1	0.85	76.0	1138	1.35	6.30	3.10	3.1	35	73/74			
400	1LA4350-2AN00-Z + B20	2983	96.3	96.2	0.85	86.0	1280	1.30	6.15	2.85	4.3	38	75/76			
450	1LA4352-2AN00-Z + B20	2983	96.5	96.4	0.85	96.5	1441	1.45	6.50	3.10	4.8	43	75/76			
500	1LA4354-2AN00-Z + B20	2985	96.7	96.7	0.85	107.0	1600	1.45	6.55	3.10	5.2	46	75/76			
560	1LA4400-2AN00-Z + B20	2988	96.6	96.3	0.84	121.5	1790	1.05	6.35	3.05	7.8	26	77/78			
650	1LA4402-2AN00-Z + B20	2988	96.8	96.6	0.85	138.0	2077	1.10	6.60	3.20	8.7	27	77/78			
750	1LA4404-2AN00-Z + B20	2989	96.8	96.6	0.87	157.0	2396	1.15	6.70	3.20	9.9	30	77/78			
<b>1500 rpm, 4-pole</b>																
200	1LA4310-4AN00-Z + B20	1484	94.4	94.2	0.74	50.0	1287	1.40	5.75	2.80	2.8	159	75/77			
250	1LA4312-4AN00-Z + B20	1485	95.2	95.2	0.79	58.0	1608	1.40	6.15	2.85	3.5	201	75/77			
300	1LA4314-4AN00-Z + B20	1484	95.4	95.4	0.80	69.5	1931	1.55	6.35	2.95	4.0	222	75/77			
365	1LA4316-4AN00-Z + B20	1485	95.9	95.9	0.80	83.5	2346	1.55	6.35	2.95	4.8	297	75/77			
400	1LA4350-4AN00-Z + B20	1488	95.8	95.6	0.77	95.0	2566	1.55	6.20	3.05	6.0	224	77/79			
470	1LA4352-4AN00-Z + B20	1488	96.1	96.0	0.80	105.5	3017	1.45	6.15	2.85	6.9	247	77/79			
560	1LA4354-4AN00-Z + B20	1489	96.4	96.3	0.82	124.0	3592	1.60	6.40	2.95	8.1	296	77/79			
630	1LA4400-4AN00-Z + B20	1491	96.4	96.2	0.80	143.0	4036	1.45	6.35	3.05	11.6	288	79/81			
710	1LA4402-4AN00-Z + B20	1491	96.6	96.4	0.81	159.0	4548	1.45	6.40	3.05	12.9	330	79/81			
800	1LA4404-4AN00-Z + B20	1491	96.7	96.5	0.82	177.5	5125	1.45	6.45	3.05	14.5	381	79/81			
<b>1000 rpm, 6-pole</b>																
236	1LA4314-6AN00-Z + B20	989	94.8	94.8	0.77	57.0	2279	1.50	6.10	3.05	5.3	375	69/72			
270	1LA4316-6AN00-Z + B20	988	95.1	95.2	0.78	62.5	2609	1.55	6.45	2.95	6.4	431	69/72			
315	1LA4350-6AN00-Z + B20	991	95.5	95.4	0.78	74.5	3034	1.35	6.20	2.80	10.8	541	71/74			
365	1LA4352-6AN00-Z + B20	991	95.8	95.7	0.79	84.5	3515	1.35	6.20	2.70	12.7	667	71/74			
425	1LA4354-6AN00-Z + B20	992	95.9	95.8	0.78	99.5	4091	1.55	6.40	2.95	15.0	841	71/74			
490	1LA4400-6AN00-Z + B20	993	96.0	95.9	0.81	111.5	4713	1.30	6.50	2.80	21.2	740	73/76			
570	1LA4402-6AN00-Z + B20	994	96.3	96.2	0.81	128.5	5476	1.35	6.45	2.80	24.2	1193	73/76			
630	1LA4404-6AN00-Z + B20	993	96.4	96.2	0.78	146.5	6060	1.45	6.45	2.95	27.3	1233	73/76			

1) Temperature class F, utilization in accordance with B.

2) Measured at distance of 1 m in accordance with DIN 45635 (Part 1), tolerance +3 dB(A).

# High-Voltage Motors H-compact Standardline

## Operation on supply system

Rated output 1)	Order No. + order codes for further options	Operating values at rated output						Starting torque	Starting current	Stalling torque	Moment of inertia J		Sound pressure level 2)			
		Rated speed	Efficiency $\eta$ with		Power factor $\cos \varphi$	Rated current	Rated torque				with direct starting as multiple of rated			Motor	External max. perm.	
			4/4 load	3/4 load							torque	current				torque
kW		rpm	%	%	A	Nm							dB(A)			
<b>6 kV, 50 Hz</b>																
<b>3000 rpm, 2-pole</b>																
200	1LA4310-2AN60-Z + B20	2970	95.2	95.2	0.87	23.0	643	0.90	5.00	2.30	2.2	28	73/74			
236	1LA4312-2AN60-Z + B20	2967	95.0	95.2	0.87	27.5	759	0.90	5.00	2.30	2.2	26	73/74			
300	1LA4314-2AN60-Z + B20	2972	95.7	95.8	0.88	34.5	964	1.05	5.20	2.40	2.7	30	73/74			
355	1LA4316-2AN60-Z + B20	2974	96.2	96.2	0.88	40.5	1140	1.10	5.30	2.50	3.1	35	73/74			
400	1LA4350-2AN60-Z + B20	2978	96.1	96.2	0.88	45.5	1283	1.05	5.20	2.30	4.3	38	75/76			
450	1LA4352-2AN60-Z + B20	2978	96.4	96.4	0.88	51.0	1443	1.20	5.50	2.50	4.8	43	75/76			
500	1LA4354-2AN60-Z + B20	2980	96.6	96.7	0.88	57.0	1602	1.20	5.50	2.50	5.2	46	75/76			
560	1LA4400-2AN60-Z + B20	2984	96.5	96.4	0.88	64.0	1792	0.85	5.40	2.50	7.8	26	77/78			
650	1LA4402-2AN60-Z + B20	2985	96.8	96.7	0.88	73.0	2079	0.90	5.60	2.60	8.7	27	77/78			
750	1LA4404-2AN60-Z + B20	2985	97.0	96.9	0.89	84.0	2399	0.95	5.60	2.60	9.9	30	77/78			
<b>1500 rpm, 4-pole</b>																
200	1LA4310-4AN60-Z + B20	1480	94.3	94.4	0.81	25.0	1290	1.15	5.20	2.30	2.8	159	75/77			
250	1LA4312-4AN60-Z + B20	1480	95.0	95.2	0.84	30.0	1613	1.15	5.30	2.30	3.5	201	75/77			
300	1LA4314-4AN60-Z + B20	1480	95.2	95.4	0.85	36.0	1936	1.25	5.50	2.40	4.0	222	75/77			
365	1LA4316-4AN60-Z + B20	1481	95.7	95.9	0.85	43.5	2353	1.25	5.50	2.40	4.8	297	75/77			
400	1LA4350-4AN60-Z + B20	1485	95.7	95.8	0.84	48.0	2572	1.25	5.50	2.50	6.0	224	77/79			
470	1LA4352-4AN60-Z + B20	1484	95.9	96.0	0.85	55.0	3024	1.20	5.30	2.35	6.9	247	77/79			
560	1LA4354-4AN60-Z + B20	1485	96.2	96.3	0.86	65.0	3601	1.30	5.50	2.40	8.1	296	77/79			
630	1LA4400-4AN60-Z + B20	1488	96.3	96.3	0.85	74.0	4043	1.20	5.50	2.50	11.6	288	79/81			
710	1LA4402-4AN60-Z + B20	1488	96.5	96.5	0.85	83.0	4556	1.20	5.50	2.50	12.9	330	79/81			
800	1LA4404-4AN60-Z + B20	1488	96.6	96.6	0.86	93.0	5134	1.20	5.50	2.50	14.5	381	79/81			
<b>1000 rpm, 6-pole</b>																
236	1LA4314-6AN60-Z + B20	986	94.6	94.9	0.82	29.5	2286	1.25	5.30	2.50	5.3	375	69/72			
270	1LA4316-6AN60-Z + B20	985	94.8	95.2	0.82	33.0	2617	1.25	5.50	2.40	6.4	431	69/72			
315	1LA4350-6AN60-Z + B20	989	95.3	95.5	0.82	39.0	3041	1.10	5.30	2.30	10.8	541	71/74			
365	1LA4352-6AN60-Z + B20	989	95.6	95.8	0.83	44.5	3524	1.10	5.30	2.20	12.7	667	71/74			
425	1LA4354-6AN60-Z + B20	990	95.8	95.9	0.82	52.0	4099	1.25	5.50	2.40	15.0	841	71/74			
490	1LA4400-6AN60-Z + B20	991	95.9	96.0	0.84	59.0	4722	1.05	5.50	2.30	21.2	740	73/76			
570	1LA4402-6AN60-Z + B20	992	96.2	96.3	0.84	68.0	5487	1.10	5.50	2.30	24.2	1193	73/76			
630	1LA4404-6AN60-Z + B20	991	96.3	96.3	0.82	77.0	6071	1.20	5.50	2.40	27.3	1233	73/76			

1) Temperature class F, utilization in accordance with B.

2) Measured at distance of 1 m in accordance with DIN 45635 (Part 1), tolerance +3 dB(A).

# High-Voltage Motors H-compact Standardline

## Operation on supply system

Rated output 1)	Order No. + order codes for further options	Operating values at rated output						Starting torque	Starting current	Stalling torque	Moment of inertia J		Sound pressure level 2)			
		Rated speed	Efficiency $\eta$ with		Power factor $\cos \varphi$	Rated current	Rated torque				with direct starting as multiple of rated			Motor	External max. perm.	
			4/4 load	3/4 load							torque	current				torque
kW		rpm	%	%	A	Nm							dB(A)			
<b>6.6 kV, 50 Hz</b>																
<b>3000 rpm, 2-pole</b>																
<b>200</b>	<b>1LA4310-2AN70-Z + B20</b>	2977	95.4	95.2	0.85	21.5	641	1.10	6.00	2.80	2.2	28	73/74			
<b>236</b>	<b>1LA4312-2AN70-Z + B20</b>	2975	95.2	95.2	0.84	26.0	757	1.10	5.90	2.80	2.2	26	73/74			
<b>300</b>	<b>1LA4314-2AN70-Z + B20</b>	2978	95.9	95.7	0.85	32.5	962	1.30	6.15	2.95	2.7	30	73/74			
<b>355</b>	<b>1LA4316-2AN70-Z + B20</b>	2980	96.3	96.1	0.85	38.0	1138	1.35	6.30	3.05	3.1	35	73/74			
<b>400</b>	<b>1LA4350-2AN70-Z + B20</b>	2983	96.3	96.2	0.85	43.0	1280	1.30	6.10	2.80	4.3	38	75/76			
<b>450</b>	<b>1LA4352-2AN70-Z + B20</b>	2983	96.5	96.3	0.85	48.0	1441	1.45	6.50	3.05	4.8	43	75/76			
<b>500</b>	<b>1LA4354-2AN70-Z + B20</b>	2985	96.7	96.7	0.85	53.5	1600	1.45	6.50	3.05	5.2	46	75/76			
<b>560</b>	<b>1LA4400-2AN70-Z + B20</b>	2988	96.5	96.3	0.84	60.5	1790	1.00	6.30	3.05	7.8	26	77/78			
<b>650</b>	<b>1LA4402-2AN70-Z + B20</b>	2988	96.8	96.6	0.85	69.0	2077	1.10	6.60	3.20	8.7	27	77/78			
<b>750</b>	<b>1LA4404-2AN70-Z + B20</b>	2989	97.1	96.8	0.87	78.5	2396	1.15	6.70	3.20	9.9	30	77/78			
<b>1500 rpm, 4-pole</b>																
<b>200</b>	<b>1LA4 310-4AN70-Z + B20</b>	1484	94.4	94.2	0.74	25.0	1287	1.40	5.75	2.80	2.8	159	75/77			
<b>250</b>	<b>1LA4 312-4AN70-Z + B20</b>	1485	95.2	95.2	0.79	29.0	1609	1.40	6.10	2.80	3.5	201	75/77			
<b>300</b>	<b>1LA4 314-4AN70-Z + B20</b>	1484	95.4	95.3	0.80	35.0	1931	1.55	6.30	2.95	4.0	222	75/77			
<b>365</b>	<b>1LA4 316-4AN70-Z + B20</b>	1485	95.9	95.9	0.80	42.0	2346	1.55	6.35	2.95	4.8	297	75/77			
<b>400</b>	<b>1LA4 350-4AN70-Z + B20</b>	1488	95.8	95.6	0.77	47.5	2567	1.50	6.20	3.05	6.0	224	77/79			
<b>470</b>	<b>1LA4 352-4AN70-Z + B20</b>	1488	96.1	96.0	0.80	53.0	3017	1.45	6.15	2.85	6.9	247	77/79			
<b>560</b>	<b>1LA4 354-4AN70-Z + B20</b>	1490	96.4	96.3	0.82	62.0	3592	1.55	6.40	2.95	8.1	296	77/79			
<b>630</b>	<b>1LA4 400-4AN70-Z + B20</b>	1491	96.4	96.2	0.80	71.5	4036	1.45	6.35	3.05	11.6	288	79/81			
<b>710</b>	<b>1LA4 402-4AN70-Z + B20</b>	1491	96.6	96.4	0.81	79.5	4548	1.45	6.40	3.05	12.9	330	79/81			
<b>800</b>	<b>1LA4 404-4AN70-Z + B20</b>	1491	96.7	96.5	0.82	88.5	5125	1.45	6.40	3.05	14.5	381	79/81			
<b>1000 rpm, 6-pole</b>																
<b>236</b>	<b>1LA4 314-6AN70-Z + B20</b>	989	94.8	94.8	0.77	28.5	2279	1.50	6.10	3.05	5.3	375	69/72			
<b>270</b>	<b>1LA4 316-6AN70-Z + B20</b>	988	95.1	95.2	0.78	31.5	2609	1.55	6.45	2.95	6.4	431	69/72			
<b>315</b>	<b>1LA4 350-6AN70-Z + B20</b>	991	95.5	95.4	0.78	37.0	3034	1.35	6.15	2.80	10.8	541	71/74			
<b>365</b>	<b>1LA4 352-6AN70-Z + B20</b>	991	95.8	95.7	0.79	42.0	3515	1.35	6.20	2.70	12.7	667	71/74			
<b>425</b>	<b>1LA4 354-6AN70-Z + B20</b>	992	95.9	95.8	0.78	50.0	4091	1.55	6.40	2.95	15.0	841	71/74			
<b>490</b>	<b>1LA4 400-6AN70-Z + B20</b>	993	96.0	95.9	0.81	55.5	4713	1.30	6.45	2.80	21.2	740	73/76			
<b>570</b>	<b>1LA4 402-6AN70-Z + B20</b>	994	96.3	96.2	0.81	64.5	5476	1.35	6.45	2.80	24.2	1193	73/76			
<b>630</b>	<b>1LA4 404-6AN70-Z + B20</b>	993	96.4	96.2	0.78	73.0	6060	1.45	6.45	2.95	27.3	1233	73/76			

1) Temperature class F, utilization in accordance with B.

2) Measured at distance of 1 m in accordance with DIN 45635 (Part 1), tolerance +3 dB(A).

### Ordering example:

High-voltage motor  
H-compact Standardline basic version  
6.6 kV, 50 Hz, 1500 rpm, 4-pole, 300 kW  
with option M13: Anti-condensation heating for 230 V

**1LA4314-4AN70-Z  
+B20+M13**

### Options

Option description	Order code	Comment
Standardline design	<b>B20</b>	Always state
Motor protection through PTC thermistor with 6 built-in temperature sensors for alarm and switch-off	<b>A12</b>	
Motor temperature sensing by means of 6 built-in PT100 G resistance thermometers	<b>A65</b>	Standard
Installation of 2 screw-in PT100 resistance thermometers in basic circuit for rolling-contact bearings	<b>A40</b>	
Nipples for SPM (shock pulse measurement)	<b>G50</b>	Standard
Connection box on RHS (view onto DE)	<b>K09</b>	
Connection box on LHS (view onto DE)	<b>K10</b>	
Connection box at 90° angle, cable from DE	<b>K83</b>	
Connection box at 90° angle, cable from NDE	<b>K84</b>	
Connection box at 180° angle, cable from top	<b>K85</b>	
Special finish in standard color RAL 7030	<b>K26</b>	
Anti-condensation heating for 110 V	<b>M12</b>	
Anti-condensation heating for 230 V	<b>M13</b>	
Supplementary (second) auxiliary connection box in grey cast iron	<b>M50</b>	
Separate auxiliary connection box for anti-condensation heating	<b>M52</b>	
Version for clockwise rotation	<b>K97</b>	
Version for counter-clockwise rotation	<b>K98</b>	
Ambient temperature 45 °C	<b>D11</b>	With utilization in accordance with F
Ambient temperature 50 °C	<b>D12</b>	With utilization in accordance with F
Ambient temperature 55 °C	<b>D13</b>	With utilization in accordance with F
Standard paint finish in a color different from RAL 7030	<b>Y53</b>	Plain text required
<b>Documentation</b>		
Documentation in English	-	Standard
Documentation in German	<b>D00</b>	
Documentation in Russian	<b>D56</b>	
Documentation in Italian	<b>D72</b>	
Documentation in French	<b>D77</b>	
Documentation in Spanish	<b>D78</b>	
Documentation in Portuguese	<b>D79</b>	
Documentation in Swedish	<b>D83</b>	
Documentation in Chinese	<b>D84</b>	
Documentation on CD-ROM	<b>B21</b>	



# High-Voltage Motors H-compact Standardline

## Operation on supply system

### Dimensional drawings

#### Design:

Type IM B3, rolling-contact bearing, degree of protection IP55,  
type of cooling IC 441

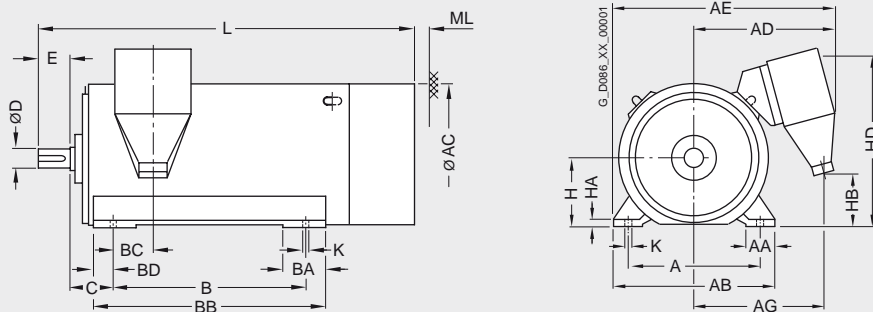

Type	Weight kg	A mm	AD mm	AE mm	B mm	C mm	H mm	HD mm	L mm	D mm	E mm
<b>2-pole</b>											
1LA4310-2	1550	610	710	1075	710	200	315	860	1590	70	105
1LA4312-2	1550	610	710	1075	710	200	315	860	1590	70	105
1LA4314-2	1850	610	710	1075	900	200	315	860	1790	70	105
1LA4316-2	2000	610	710	1075	900	200	315	860	1790	70	105
1LA4350-2	2300	686	740	1155	1000	224	355	930	1930	75	105
1LA4352-2	2400	686	740	1155	1000	224	355	930	1930	75	105
1LA4354-2	2550	686	740	1155	1000	224	355	930	1930	75	105
1LA4400-2	3150	750	775	1120	1120	254	400	1010	2095	85	130
1LA4402-2	3300	750	775	1120	1120	254	400	1010	2095	85	130
1LA4404-2	3550	750	775	1120	1120	254	400	1010	2095	85	130
<b>4-pole</b>											
1LA4310-4	1500	610	710	1075	710	200	315	860	1610	90	130
1LA4312-4	1650	610	710	1075	710	200	315	860	1610	90	130
1LA4314-4	1900	610	710	1075	900	200	315	860	1810	90	130
1LA4316-4	2050	610	710	1075	900	200	315	860	1810	90	130
1LA4350-4	2350	686	740	1155	1000	224	355	930	1985	100	165
1LA4352-4	2550	686	740	1155	1000	224	355	930	1985	100	165
1LA4354-4	2750	686	740	1155	1000	224	355	930	1985	100	165
1LA4400-4	3400	750	775	1125	1120	254	400	1010	2125	120	165
1LA4402-4	3600	750	775	1125	1120	254	400	1010	2125	120	165
1LA4404-4	3800	750	775	1125	1120	254	400	1010	2125	120	165
<b>6-pole</b>											
1LA4314-6	1950	610	710	1075	900	200	315	860	1810	90	130
1LA4316-6	2150	610	710	1075	900	200	315	860	1810	90	130
1LA4350-6	2400	686	740	1155	1000	224	355	930	1985	100	165
1LA4352-6	2600	686	740	1155	1000	224	355	930	1985	100	165
1LA4354-6	2850	686	740	1155	1000	224	355	930	1985	100	165
1LA4400-6	3500	750	775	1225	1120	254	400	1010	2125	120	165
1LA4402-6	3750	750	775	1225	1120	254	400	1010	2125	120	165
1LA4404-6	4000	750	775	1225	1120	254	400	1010	2125	120	165



### More information

#### Description - construction details

##### Housing, cooling system

The stator housing on all motors is made of grey cast iron.

The housing contains 4 axial cooling air ducts equally spaced around the circumference.

The main and auxiliary connection boxes are bolted onto the two upper ducts, which also contain the winding conductors and monitoring cables.

The two bottom ducts are located in the foot area.

These cooling air ducts are a component of the supplementary inner cooling circuit that is a feature of Siemens H-compact and N-compact motors. This cooling circuit ensures even thermal distribution within the motor and provides for optimum cooling. The resulting bearing and winding overhang temperatures have a positive impact on the service life and availability of the motors.

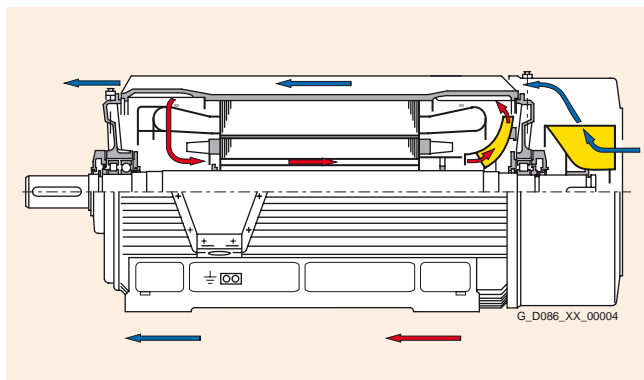

##### Hoisting gear

Two diagonally arranged, reversible hoisting lugs which align automatically with the lifting cable, i.e. according to the applied direction of force.

##### Rotor construction

The rotor winding is made of die-cast aluminum.

The aluminum is poured into the rotor slots under pressure and thus bonded with the rotor laminations in a positive connection. This method of manufacture precludes any risk of cage movement or cage "creepage" in the rotor core.

Another advantage of the die-cast method is the excellent thermal coupling between the cage and laminated rotor core, resulting in high permissible starting and rotor locking times.

##### Shaft

All motors have a shaft extension designed according to DIN 748 "short" with key steel featherkey according to DIN 6880. The rotors are balanced with half-key.

##### Direction of rotation, fans and fan shroud

**The direction of rotation must be stated in every order!**

On 2-pole motors, the external fan is a low-noise, direction-dependent axial fan. 4-pole and 6-pole motors are equipped with a direction-neutral radial fan.

The external fan is covered by a sheet-steel shroud.

##### Vibration response

H-compact Standardline motors comply with vibration severity grade N as stipulated by IEC 60034-14, or grade A according to the revised version of IEC 60034-14 (valid from December 2006). The vibration levels remain well below limit values in most cases.

##### Insulation system

The SIEMENS-MICALASTIC® insulation system, tried and tested on high-power high-voltage motors for many years, has been used on the H-compact Standardline range.

The MICALASTIC insulation system complies with temperature class F, thermally utilized according to B (in normal operation).

An important element is the VPI (Vacuum Pressure Impregnation) process which is specially tailored to this insulation system.

The winding is resistant to system transfers with 100% residual field and switching operations up to 110% with phase opposition.

The surge withstand capability of the insulation satisfies insulation coordination requirements. The insulation properties exceed the values ( $V_p = 4 \times V_{rated} + 5 \text{ kV}$ ) stipulated in DIN EN 60034-15/VDE 0530-15.

##### Noise

H-compact Standardline motors are low-noise machines. This is achieved by:

- Motor construction designed for low noise
- Optimization of external ventilation
- Fans with good air-flow form design
- Noise-optimized construction of steel fan shroud
- Number of stator and rotor slots carefully selected for low magnetic noise excitation

##### Switching frequency

H-compact Standardline motors are designed for continuous operation in accordance with IEC / VDE 0530 Part 1. The permissible switching frequency limit is 5000 starts per year.

# High-Voltage Motors H-compact Standardline

## Operation on supply system

### Connection box 1XA8711

Rated voltage 6.6 kV, up to 315 A, 3 connections (M16) for mains connection

- Up to 240 mm<sup>2</sup> conductor cross section with cable lug in accordance with DIN 46234,
- Up to 400 mm<sup>2</sup> conductor cross section with cable lug in accordance with DIN 46235,
- Alternatively, connection without cable lug,

Internal ground connection

Mounted on motor on RHS at DE (looking towards the DE shaft end).

As an option, the connection box can be mounted on LHS at DE, rotated through an angle of 90° or 180°.

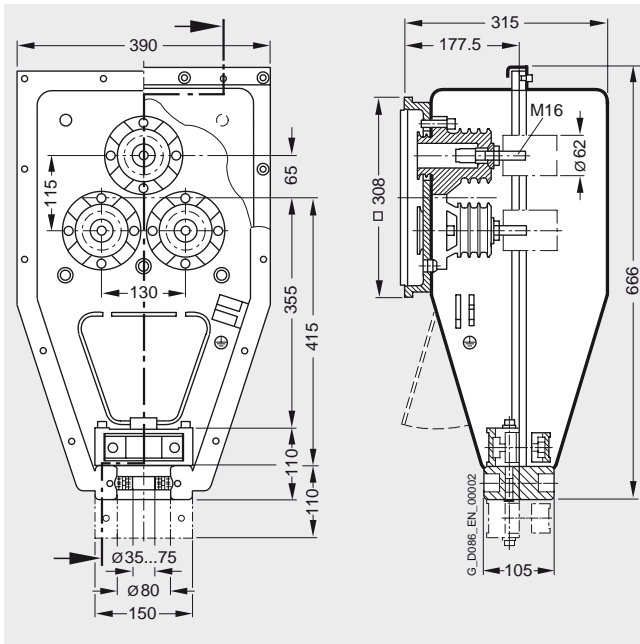

### Auxiliary connection box 1XB9014

The auxiliary connection box is designed to hold connections for connecting monitoring elements, heating, etc. It is made of aluminum and is shipped as standard with a cable entry plate without drill holes. This means that the cable entry parameters do not need to be clarified in advance when the motor is ordered. The plate is secured by 2 or 4 screws and can be removed easily for machining with the required entry holes.

- Dimensions (W x D x H): 360 x 160 x 90 mm
- No. of connections: 35
- Max. box mounting height: 50 mm

### Paint finish

Two paint systems - standard paint and special paint - are available for protecting motors against corrosion. They satisfy the following requirements relating to environmental conditions:

The **Standard paint** is categorized in the "Moderate" climate group as specified by IEC 721-2-1.

It is suitable for

- installation indoors or outdoors under cover, without direct natural weathering.
- Temperatures up to +120 °C for short periods or +100 °C continuously.
- Rel. air humidity up to 100% at temperatures up to +30 °C for short periods, up to 85% at temperatures up to +25 °C continuously.

Normal paint system:

- Primer approx. 30 µm on parts which can be dipped (casting), approx. 60 µm on parts which can be sprayed (steel)
- Final coat approx. 30 µm

The **Special paint** is categorized in the "Worldwide" climate group as specified by IEC 721-2-1.

It is suitable for

- installation outdoors with direct exposure to solar radiation and weathering over a wide temperature and humidity range (industrial or coastal areas are typical installation sites).
- Temperatures up to +140 °C for short periods or +120 °C continuously.

Special paint system:

- Primer approx. 30 µm on parts which can be dipped (casting), approx. 60 µm on parts which can be sprayed (steel)
- Final coat approx. 60 µm

The primer coat is applied to internal and external surfaces, the final coat to external surfaces.

Increased total film thicknesses, e.g. 120 or 150 µm, are available at an additional cost.

### Bearing construction

The motors are equipped with deep-groove ball bearings in accordance with DIN 625.

The location bearing is positioned at the DE.

All rolling-contact bearings are lubricated with mineral-oil-based lithium soap grease. The bearings have a re-greasing device with flat grease nipple M10 x 1 to DIN 3404 and a collector for used grease which is large enough to cover the calculated bearing life when the re-greasing intervals and quantities are observed (lubrication data can be found on lubrication plate or in order documentation).

The rolling-contact bearings are sealed externally by V-ring seals and internally by gap seals.