

Installation, Operation and Maintenance

Series 1011, Series 1012, Series 1011G



1011



1012

Receiving, Handling and Inspection

1. Unpack and inspect suction diffuser for damage which may have occurred during shipping. Any damage should be reported to the carrier immediately.
2. Remove suction diffuser flange covers and inspect for any foreign matter that could be washed downstream when the suction diffuser is put into service.
3. Carefully check the pressure and temperature ratings on the suction diffuser body or nameplate to be sure that they are correct for the intended application. Store the suction diffuser in a dry, clean area until it is installed.

Recommended Mounting Position

The upstream side of the suction diffuser may be placed vertically or horizontally. Positioning bosses for a pipe support are located on 3 sides of the suction diffuser body. See table for pipe support inside diameters to fit each size of suction diffuser.

Installation

1. Two dimensions are used to designate the size of suction diffusers. The first is the inlet size; the second is the outlet size. Example: 3" x 2" suction diffuser has a three-inch inlet and a two-inch outlet flange.
2. Place the suction diffuser so that the head of the flow arrow points to the suction flange (inlet) of the pump. Full-face gaskets must be used on flat flanges. Pump and suction diffuser flanges should be aligned before final connections are made. Do not draw piping into place by force. Flange bolts should be only finger tight.
3. Suction and discharge piping should be properly supported so that the weight of piping does not rest on pump. To support the suction diffuser cut a piece of pipe with the correct inside diameter (see table) to the approximate length from the boss to the adjustable foot. Take this measure with the foot adjusted to its shortest position. Place the pipe over the boss and on the foot. Adjust the nut upward until the weight of the suction diffuser is properly supported.
4. Tighten all flange bolts in sequence crossing to opposites. Slowly bring system to working pressure and check for leaks. If pressure gauges are installed be sure that threaded fittings are properly sealed. If leaks occur, check for piping and flange misalignment. If there is no misalignment, retighten flange bolting.

Start-up Service

After 30 days of operation, the temporary mesh sleeve around the perforated screen should be removed. See Cleaning & Servicing. (Back page)

Cleaning & Servicing

We recommended that pressure gauges be installed on the suction diffuser inlet and outlet or the suction diffuser inlet and suction side of the pump to indicate when cleaning is required. Record the pressure drop when the suction diffuser is clean. When the indicated pressure drop doubles, the suction diffuser should be cleaned.

1. Shut down the pump and close the upstream and downstream isolation valves.
2. Remove the NPT plug on the body of the suction diffuser and allow to drain.
3. Loosen knobs (or nuts) and remove cover. Do not use sharp objects to pry cover from body or the o-ring seal may be damaged.
4. Remove and clean perforated screen. The temporary mesh sleeve should be removed and thrown away after the 30-day start-up period. Inspect the perforated screen for damage and replace if necessary.

5. Before reassembling the suction diffuser, inspect the o-ring seal for cuts or other damage and replace if necessary.
6. When reassembling, be sure that the o-ring is seated against the cover and that the screen is seated snugly in the recess of the cover. Reinstall cover and tighten cover knobs (or nuts) in sequence crossing to opposites.
7. Open upstream isolation valve slowly to bring the system back up to working pressure. If there are no leaks open the downstream isolation valve and restart the system. If leakage occurs the cover should be checked for proper seating. Retighten knobs (or nuts)

Note: For a "quick clean", a blow down valve may be substituted for the NPT plug. Opening this valve with the system running will flush out most of the accumulated sediment from the suction diffuser. We do not recommend this procedure for the first service after start-up. This procedure should be used only if it is not possible to carry out scheduled maintenance on the suction diffuser described in Steps 1 – 7.

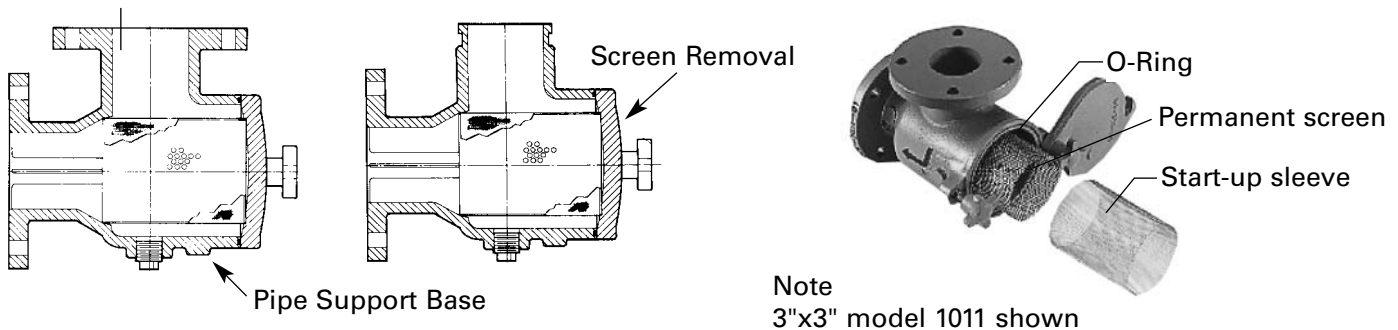

Table of Screen Removal Allowances & Pipe Support Inside Diameters

Size Inlet x Outlet	2" x 1 1/4"	2 1/2" x 2"	3" x 2"	4" x 3"	5" x 4"	6" x 4"	8" x 6"	8" x 8"	10" x 8"	10" x 10"	12" x 8"	12" x 10"	12" x 12"
	2" x 1 1/2"	2 1/2" x 2 1/2"	3" x 2 1/2"	4" x 4"	5" x 5"	6" x 5"							
	2" x 2"		3" x 3"			6" x 6"							
Screen Removal	8 13/16	9 1/8	9 5/8	11 1/2	14 7/8	16 9/16	16 7/8	22 7/8	22 7/8	30 1/4	22 7/8	33	28 3/4
Pipe Support ID													
1011	0.824	1.049	1.049	1.380	1.380	1.380	1.380	1.380	1.380	2.067	1.380	2.067	2.067
1012	0.824	1.380	1.380	1.380	-	1.380	1.380	1.380	1.380	2.067	-	2.067	-
1011G	0.824	1.380	1.380	1.380	-	1.380	1.380	1.380	1.380	1.380	-	1.380	-

Consult Factory for other sizes and dimensions

CALIFORNIA PROPOSITION 65 WARNING
WARNING: This product contains chemicals known to the State of California to cause cancer and birth defects or other reproductive harm. (California law requires this warning to be given to customers in the State of California.)
 For more information: www.watts.com/prop65

Limited Warranty: Mueller Steam Specialty warrants each product to be free from defects in material and workmanship under normal usage for a period of one year from the date of original shipment. In the event of such defects within the warranty period, the Company will, at its option, replace or recondition the product without charge. This shall constitute the sole and exclusive remedy for breach of warranty, and the Company shall not be responsible for any incidental, special or consequential damages, including without limitation, lost profits or the cost of repairing or replacing other property which is damaged if this product does not work properly, other costs resulting from labor charges, delays, vandalism, negligence, fouling caused by foreign material, damage from adverse water conditions, chemical, or any other circumstances over which the Company has no control. This warranty shall be invalidated by any abuse, misuse, misapplication or improper installation of the product. **THIS WARRANTY IS IN LIEU OF ALL OTHER WARRANTIES, EXPRESS OR IMPLIED, INCLUDING ANY IMPLIED WARRANTIES OF MERCHANTABILITY OR FITNESS FOR A PARTICULAR PURPOSE.** Any implied warranties that are imposed by law are limited in duration to one year.

Some States do not allow limitations on how long an implied warranty lasts, and some States do not allow the exclusion or limitation of incidental or consequential damages. Therefore the above limitations may not apply to you. This Limited Warranty gives you specific legal rights, and you may have other rights that vary from State to State. You should consult applicable state laws to determine your rights.



A Division of Watts Water Technologies, Inc.

USA: 1491 NC Hwy 20 West St.; Pauls, NC 28384; www.muellersteam.com

Tel: 910-865-8241 Fax: 910-865-6220

Toll Free Phone 1-800-334-6259 Toll Free Fax: 1-800-421-6772