

Class 125 Iron Body Check Valves

Twin Disc • Wafer Style • Bronze Disc • Rubber Seat • Spring Actuated

250 PSI/17.2 Bar Non-Shock Cold Working Pressure
Maximum Temperature to 180° F/82° C

CONFORMS TO ANSI B16.1

MATERIAL LIST

PART	SPECIFICATION
1. Body	Ductile Iron ASTM A 536 Grade 65-45-12
2. Disc	Bronze ASTM B 584 UNS C83600
3. Torsion Spring	Stainless Steel ASTM A 313 UNS S31600
4. Disc Thrust Bearing	Stainless Steel ASTM A 240 UNS S31600
5. Stabilization Sphere	Nitrile ASTM D 2000
6. Hinge Pin Retainer	Steel
7. Stop Pin Retainer	Steel
8. Disc Hinge Pin	Stainless Steel ASTM A 276 UNS S31600
9. Spacer	Stainless Steel ASTM A 276 UNS S31600
10. Disc Stop Pin	Stainless Steel ASTM A 276 UNS S31600



W-920-W
Wafer

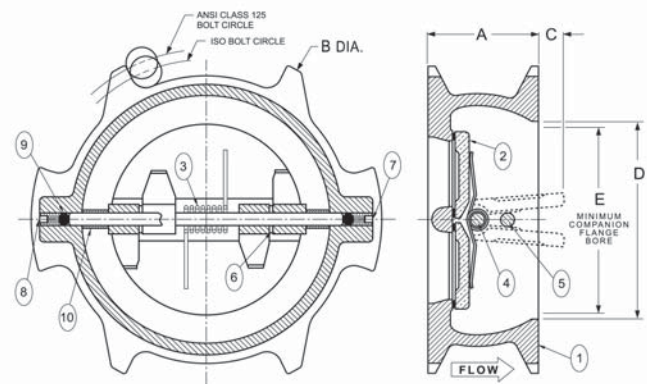

2" thru 12"

DIMENSIONS—WEIGHTS—QUANTITIES

Size		Dimensions										Weight	
		A		B		C		D		E			
In.	mm.	In.	mm.	In.	mm.	In.	mm.	In.	mm.	In.	mm.	Lbs.	Kg.
2	50	2.13	54	5.13	130	—	—	2.88	73	—	—	4	2
2½	65	2.38	60	6.00	152	.13	3.3	3.50	89	1.31	33	5	2
3	80	2.63	67	5.63	143	.19	4.8	3.88	99	1.69	43	7	3
4	100	2.63	67	7.75	197	.63	16.0	4.75	121	3.06	78	9	4
5	125	3.25	83	7.56	192	.81	20.0	5.50	140	3.63	92	13	6
6	150	3.75	95	8.63	222	.81	32.0	6.25	171	4.25	146	19	9
8	200	5.00	127	12.25	279	1.00	33.0	8.00	222	5.50	197	37	17
10	250	5.50	140	14.75	340	2.06	64.0	10.25	276	8.50	248	65	30
12	300	7.13	181	17.38	410	1.94	60.0	12.00	327	9.25	279	94	43

NOTE: Twin Disc Check Valves can be installed horizontally or in the vertical position with flow up.

CAUTION: For horizontal flow applications, the valve must be installed with disc hinge pin in the vertical position, to insure proper operation.

WARNING: 1. Seat end of valve must be mated to a standard flat faced metal flange. Rubber flanges not acceptable.

2. These are not to be used as steam valves.

3. Valves are not to be used near a reciprocating air compressor.

4. Install 5 pipe diameters minimum downstream from pump discharge or elbows to avoid flow turbulence. Flow straighteners may be required in extreme cases.

NOTE: On pump discharge, the preferred check valves are in-line spring loaded, swing design with lever and weight or lever and spring.

◆ For detailed Operating Pressure, refer to Pressure Temperature Chart on page 111.