

Class 150 Ductile Iron Body Gate Valves

Raised Face Flanges • Bolted Bonnet • Non-Rising Stem •
Solid Wedge • B 584 Bronze Trim

**285 PSI/19.7 Bar Non-Shock Cold Working Pressure
to -20° F to 100° F/-29° C to 38° C**
185 PSI/12.8 Bar Saturated Steam to 450°F/232°C ♦

CONFORMS TO MSS SP-128

MATERIAL LIST

PART	SPECIFICATION
1. Handwheel Nut	Steel ASTM A 307
2. Identification Plate	Aluminum
3. Handwheel	Iron ASTM A 126 Class B
4. Stem	Bronze ASTM B 371
5. Gland Follower Nut	Brass ASTM F 467
6. Gland Follower	Ductile Iron ASTM A 536
7. Gland Follower Bolt	Steel ASTM A 307
8. Packing Gland	Brass or Iron
9. Stuffing Box	Ductile Iron ASTM A 536
10. Packing	TFE Braided
11. Stuffing Box Gasket	Synthetic Fibers
12. Bonnet	Ductile Iron ASTM A 395
13. Body Bolt	Steel ASTM A 307
14. Body Gasket	Synthetic Fibers
15. Body Nut	Steel ASTM A 307
16. ² Seat Ring	Bronze ASTM B 584
17. Wedge Face Ring	Bronze ASTM B 584
18. ¹ Wedge	Ductile Iron ASTM A 395
19. Body	Ductile Iron ASTM A 395
20. Stuffing Box Nut	Steel ASTM A 307 (not shown)

¹ Sizes thru 4" made with Bronze Wedges. Sizes 5" thru 12" made with Ductile Iron Wedge with Bronze Face Rings (31 Trim).

² Lugs may be removed at customer's request - POA.

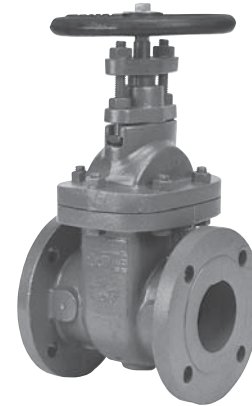

F-639-31
Flanged-Raised Face

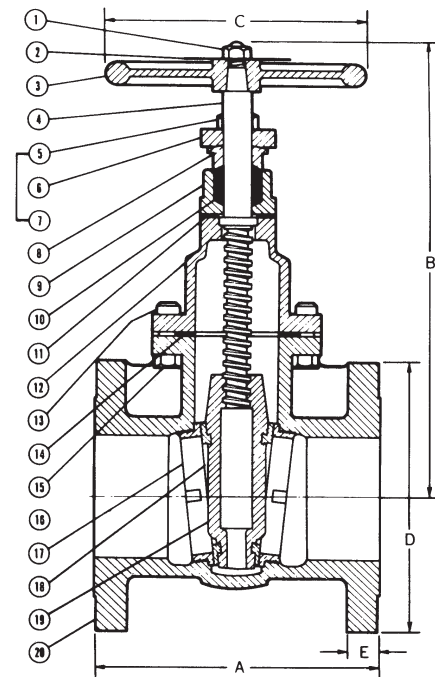

F-639-31
Flg x Flg

DIMENSIONS—WEIGHTS—QUANTITIES

Size	Dimensions										Weight		
	A		B		C		D		E		Lbs.	Kg.	
In.	mm.	In.	mm.	In.	mm.	In.	mm.	In.	mm.	In.	mm.		
2	50	7.00	178	11.00	279	7.00	178	6.00	152	.63	16	35	16
2½	65	7.50	191	12.50	318	7.00	178	7.00	178	.69	17	49	22
3	80	8.00	203	13.50	343	8.00	203	7.50	191	.75	19	60	27
4	100	9.00	229	15.75	400	10.00	254	9.00	229	.94	24	90	41
5	125	10.00	254	17.00	432	10.00	254	10.00	254	.94	24	129	59
6	150	10.50	267	21.00	533	12.00	305	11.00	279	1.00	25	161	73
8	200	11.50	292	25.00	635	14.00	356	13.50	343	1.13	29	278	126
10	250	13.00	330	29.00	737	16.00	406	16.00	406	1.19	30	419	190
12	300	14.00	356	34.50	876	18.00	457	19.00	483	1.25	32	631	286
14	350	15.00	381	40.38	1026	20.00	508	21.00	533	1.38	35	869	394
16	400	16.00	407	45.75	1162	22.00	559	23.50	597	1.44	37	1223	555

Position indicators available.

FREEZING WEATHER PRECAUTION: Subsequent to testing a piping system, valves should be left in an open position to allow complete drainage.

♦ For detailed Operating Pressure, refer to Pressure Temperature Chart on page 111.