

Models: 764-SS-WE, 765M-SS-WE*, 766M-SS-WE*, 767-SS-WE**Cast Stainless Steel Butt Weld End Y Strainers**
Sizes: 1/2" - 12" (15-300mm)

Pressure / Temperature – Non-Shock		
Model	Material	Rating
764-SS-WE	Stainless Steel	1440psi @ -20°F to 100°F
		99.28 bar @ 37.78°C
		475psi @ 1150°F 32.75 bar @ 621.11°C
765M-SS-WE	Stainless Steel	2160psi @ -20°F to 100°F
		148.93 bar @ 37.78°C
		710psi @ 1150°F 48.95 bar @ 621.11°C
766M-SS-WE	Stainless Steel	3600psi @ -20°F to 100°F
		248.21 bar @ 37.78°C
		1185psi @ 1150°F 81.70 bar @ 621.11°C
767-SS-WE	Stainless Steel	6000psi @ -20°F to 100°F
		413.69 bar @ 37.78°C
		1970psi @ 1150°F 135.83 bar @ 621.11°C

764-SS-WE	Class 600
765M-SS-WE	Class 900
766M-SS-WE	Class 1500
767-SS-WE	Class 2500



Models 764WE, 765MWE, 766MWE, 767WE

Typical Service

- Used extensively to strain foreign matter from pipelines and provide economical protection for costly pumps, meters, valves, and other similar mechanical equipment.
- Especially important where weld debris is likely present in the pipeline.
- Well suited for long service in high pressure and temperature applications.

Features

- Machined seats in both body and cap align and lock the screen in place to stop sediment bypass.
- Machined seats facilitate alignment and accurate reseating after servicing.

Construction

- Designed for high pressure and temperature services.
- Heavy gauge reinforced screens are used.

Self-Cleaning

- Self-cleaning is accomplished by opening the plug or valve connected to the blowoff outlet, if provided.
- Cleaning usually accomplished by shutting off line pressure and disassembling strainer.

Blowoff Outlets

- Cover flange for 764-SS-WE is furnished with blowoff tapping, not plugged.
- All other covers normally furnished as blind flanges. Socket weld blowoff connection available, specify on order.

Capacity

- Generously proportioned bodies.
- Open Area Ratio much greater than pipe size, ensuring low pressure drop.
- Minimum of 4 to 1 Open Area Ratio.

Special Coating and Treatments

Pickling and Passivation available on request. Consult factory.

Screens

MODEL	SIZES	STANDARD (WATER)		STEAM RECOMMENDATION	
		MATERIAL	OPENING	MATERIAL	OPENING
All	1/2" - 4"	304SS	.062 perf	304SS	.033 perf
All	5" & Up	304SS	.125 perf	304SS	.045 perf

Material

	764-SS-WE, 765M-SS-WE, 766M-SS-WE, 764-SS-WE
Body	Stainless Steel, ASTM A351 Grade CF8M
Cap	Stainless Steel, ASTM A351 Grade CF8M
Gasket	Spiral Wound SS, Graphite Filled

Pressure Drop

See Pressure Drop Charts in Technical Data Section in Mueller Steam Specialty Engineering binder.

* 765M and 766M supersede models 765/766. Consult factory.

Dimensions and Weights

SIZE		DIMENSIONS								WEIGHT	
		A		B		C		D Screen Removal			
in.	mm	in.	mm	in.	mm	in.	mm	in.	mm	lbs.	kgs.
764WE											
1/2	15	6 5/8	168	3 1/2	89	3/8	10	5	130	6	2.7
3/4	20	8 5/16	211	3 3/4	95	1/2	15	5	130	12.3	5.5
1	25	8 5/16	211	3 3/4	95	1/2	15	5	130	12.3	5.5
1 1/4	32	10 1/8	257	5 1/2	140	1/2	15	8	203	19	8.6
1 1/2	40	10 1/4	260	5 1/2	140	1/2	15	8	203	27	12
2	50	11	279	7	178	1/2	15	10	254	40	18
2 1/2	65	12	305	8 1/4	210	1	25	12 1/2	318	60	27
3	80	13 1/2	343	9 1/4	235	1 1/4	32	14 1/2	368	78	35
4	100	17 9/16	456	12 1/2	318	1 1/2	40	19 1/2	495	160	72.7
6	150	25 5/8	651	20	508	2	50	31	787	364	165
8	200	31 3/4	806	24	610	2	50	38 1/2	978	670	304
10	250	37 1/16	957	28 1/2	724	2	50	45 1/2	1156	1090	495
12	300	45 1/2	1156	34 1/2	876	2	50	52	1321	1558	708

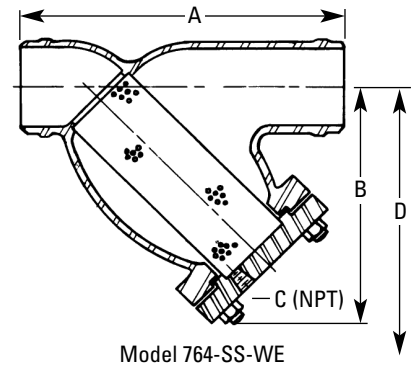

Model 764-SS-WE

SIZE		DIMENSIONS				WEIGHT	
		A		B			
in.	mm	in.	mm	in.	mm	lbs.	kgs.
765MWE							
1/2	15	8 1/8	206	4 1/4	108	20	9
3/4	20	9 1/16	230	4 3/4	121	30	14
1	25	10 11/16	271	5 3/4	146	52	23
1 1/4	32	12	305	6 3/4	171	65	29
1 1/2	40	12	305	6 3/4	171	65	29
2	50	13 5/16	354	7 1/2	191	93	42
2 1/2	65	17 1/2	445	10 3/4	273	185	84
3	80	17 1/2	445	10 3/4	273	185	84
4	100	23 3/4	591	15	381	250	113
6	150	27 3/4	705	18 7/8	479	560	254
8	200	33 1/4	846	23 1/8	606	1000	454

SIZE		DIMENSIONS				WEIGHT	
		A		B			
in.	mm	in.	mm	in.	mm	lbs.	kgs.
766MWE							
1/2	15	8 1/8	206	4 1/4	108	20	9
3/4	20	9 1/16	230	4 3/4	121	30	14
1	25	10 11/16	271	5 3/4	146	52	23
1 1/4	32	12	305	6 3/4	171	65	29
1 1/2	40	12	305	6 3/4	171	65	29
2	50	13 5/16	354	7 1/2	191	93	42
2 1/2	65	17 1/2	445	10 3/4	273	185	84
3	80	17 1/2	445	10 3/4	273	185	84
4	100	23 3/4	591	15	381	334	151
6	150	30 5/8	778	20 1/4	521	770	350
8	200	39	778	26 15/16	684	770	545
10	250	CF	CF	CF	CF	CF	CF
12	300	CF	CF	CF	CF	CF	CF

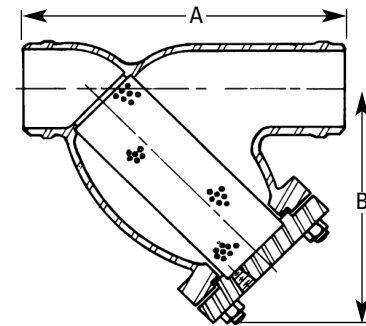

Models 765M-SS-WE,
766M-SS-WE, 767-SS-WE

SIZE		DIMENSIONS				WEIGHT	
		A		B			
in.	mm	in.	mm	in.	mm	lbs.	kgs.
767WE							
1/2	15	12 5/8	321	7 11/16	195	30	14
3/4	20	12 5/8	321	7 11/16	195	40	18
1	25	12 5/8	321	7 11/16	195	65	30
1 1/4	32	16 1/8	429	10 1/2	267	140	63.3
1 1/2	40	16 1/8	429	10 1/2	267	140	64
2	50	18 15/16	481	12 1/2	318	240	109
2 1/2	65	25 3/4	654	18 13/16	478	500	227
3	80	26 3/4	679	18 13/16	478	560	254
4	100	33 5/8	854	20 1/4	514	850	386
6	150	33 3/4	857	20	508	1900	862
8	200	CF	CF	CF	CF	CF	CF
10	250	CF	CF	CF	CF	CF	CF
12	300	CF	CF	CF	CF	CF	CF

Mueller Steam Specialty product specifications in U.S. customary units and metric are approximate and are provided for reference only. For precise measurements, please contact Mueller Steam Specialty Technical Service. Mueller Steam Specialty reserves the right to change or modify product design, construction, specifications, or materials without prior notice and without incurring any obligation to make such changes and modifications on Mueller Steam Specialty products previously or subsequently sold.



A Division of Watts Water Technologies, Inc.

USA: 1491 NC Hwy 20 West St. Pauls, NC 28384; www.muellersteam.com
Tel: 910-865-8241 Fax: 910-865-6220

Toll Free Phone 1-800-334-6259 Toll Free Fax: 1-800-421-6772