

# Models: 764-WE 765M-WE\*, 766M-WE\*, 767-WE

## Cast Carbon and Alloy Steel Butt Weld End Y Strainers Sizes: 1/2" - 12" (15 - 300mm)

Pressure / Temperature – Non-Shock		
Model	Material	Rating
764-WE	Carbon Steel	1480psi @ -20°F to 100°F
		102.04 bar @ 37.78°C
		640psi @ 850°F 44.13 bar @ 454.44°C
765M-WE	Carbon Steel	2220psi @ -20°F to 100°F
		153.06 bar @ 37.78°C
		955psi @ 850°F 65.84 bar @ 454.44°C
766M-WE	Carbon Steel	3705psi @ -20°F to 100°F
		255.45 bar @ 37.78°C
		1595psi @ 850°F 109.97 bar @ 454.44°C
767-WE	Carbon Steel	6170psi @ -20°F to 100°F
		425.41 bar @ 37.78°C
		2655psi @ 850°F 183.06 bar @ 454.44°C
764-WE	Chrome-Moly	1500psi @ -20°F to 100°F
		103.42 bar @ 37.78°C
		600psi @ 975°F 41.37 bar @ 523.89°C
765M-WE	Chrome-Moly	2250psi @ -20°F to 100°F
		155.13 bar @ 37.78°C
		900psi @ 975°F 62.05 bar @ 523.89°C
766M-WE	Chrome-Moly	3750psi @ -20°F to 100°F
		258.55 bar @ 37.78°C
		1500psi @ 975°F 103.42 bar @ 523.89°C
767-WE	Chrome-Moly	6250psi @ -20°F to 100°F
		430.92 bar @ 37.78°C
		2500psi @ 838°F 172.37 bar @ 523.89°C

**764**                      **Class 600**  
**765M**                   **Class 900**  
**766M**                   **Class 1500**  
**767**                      **Class 2500**



Models 764, 765, 765M, 766, 766M, 767



\* 765M and 766M supersede models 765/766. Consult factory.

### Typical Service

- Used extensively to strain foreign matter from pipelines and provide economical protection for costly pumps, meters, valves, and other similar mechanical equipment.
- These are especially critical as weld debris is often present in the pipeline.
- Well suited for long service in high pressure and temperature applications.

### Features

- Machined seats in both body and cap align and lock the screen in place to stop sediment bypass.
- Machined seats facilitate alignment and accurate reseating after servicing.

### Construction

- Designed for high pressure and temperature services.
- Alloy bolting for all sizes.
- IMPORTANT NOTE:
  - Class 600 and 900 strainers are machined for Schedule 80 pipe
  - Class 1500 strainers are machined for Schedule 160 pipe
  - Class 2500 strainers are machined for XXS pipe
  - Please specify on order if other connection is required

### Self-Cleaning

- Self-cleaning is accomplished by opening the plug or valve connected to the blowoff outlet, if provided.
- Cleaning usually accomplished by shutting off line pressure and disassembling strainer.

### Blowoff Outlets

- Cover flange for 764-WE furnished with blowoff tapping, not plugged.
- All other covers normally furnished as blind flanges. Socket weld blowoff connection available, specify on order.

### Capacity

- Generously proportioned bodies.
- Open Area Ratio much greater than pipe size, ensuring low pressure drop.
- Minimum of 4 to 1 Open Area Ratio.

### Screens

MODEL	SIZES	STANDARD (WATER)		STEAM RECOMMENDATION	
		MATERIAL	OPENING	MATERIAL	OPENING
All	1/2 - 4"	304SS	.062 perf	304SS	.033 perf
All	5" and Up	304SS	.125 perf	304SS	.045 perf

### Material

	764-WE, 765M-WE, 766M-WE, 767-WE
Body	Carbon Steel, ASTM A216 Grade WCB
Cap	Carbon Steel, ASTM A216 Grade WCB
Gasket	Spiral Wound SS, Graphite Filled

### ALSO AVAILABLE:

Body/Cap: Carbon-Moly ASTM A217 Gr. W1,  
 Chrome-Moly ASTM A217 Gr. WC6,  
 Chrome-Moly ASTM A217 Gr. WC9

### Pressure Drop

See Pressure Drop Charts in Technical Data Section in the Mueller Steam Specialty Engineering binder.



# Dimensions and Weights

SIZE		DIMENSIONS						WEIGHT			
		A		B		C		D Screen Removal			
in.	mm	in.	mm	in.	mm	in.	mm	in.	mm	lbs.	kg.
<b>764-WE</b>											
1/2	15	6 5/8	168	3 1/2	89	3/8	10	5	130	6	2.7
3/4	20	8 5/16	211	3 3/4	95	1/2	15	5	130	12.3	5.5
1	25	8 5/16	211	3 3/4	95	1/2	15	5	130	12.3	5.5
1 1/4	32	10 1/8	257	5 1/2	140	1/2	15	8	203	19	8.6
1 1/2	40	10 1/4	260	5 1/2	140	1/2	15	8	203	27	12
2	50	11	279	7	178	1/2	15	10	254	40	18
2 1/2	65	12	305	8 1/4	210	1	25	12 1/2	318	60	27
3	80	13 1/2	343	9 1/4	235	1 1/4	32	14 1/2	368	78	35
4	100	17 15/16	456	12 1/2	318	1 1/2	40	19 1/2	495	160	72.7
5	125	22 1/4	565	15	381	2	50	23	584	254	115
6	150	25 5/8	651	20	508	2	50	31	787	364	165
8	200	31 3/4	806	24	610	2	50	38 1/2	978	670	304
10	250	37 11/16	957	28 1/2	724	2	50	45 1/2	1156	1090	495
12	300	45 1/2	1156	34 1/2	876	2	50	52	1321	1558	708

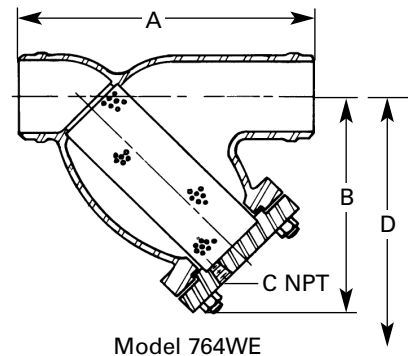

Model 764WE

SIZE		DIMENSIONS				WEIGHT	
		A		B			
in.	mm	in.	mm	in.	mm	lbs.	kg.
<b>765M-WE</b>							
1/2	15	8 1/8	206	4 1/4	108	20	9
3/4	20	9 1/16	230	4 3/4	121	30	13.6
1	25	10 11/16	271	5 3/4	146	52	23
1 1/4	32	12	305	6 3/4	171	64.5	29
1 1/2	40	12	305	6 3/4	171	64.5	29
2	50	13 15/16	354	7 1/2	191	93	42
2 1/2	65	17 1/2	445	10 3/4	273	185	84
3	80	17 1/2	445	10 3/4	273	185	84
4	100	23 1/4	591	15	381	250	113
5	125	—	—	—	—	—	—
6	150	27 3/4	705	18 7/8	479	560	254
8	200	33 1/4	846	23 7/8	606	1000	454
10	250	CF	CF	CF	CF	CF	CF
12	300	CF	CF	CF	CF	CF	CF

<b>766M-WE</b>							
in.	mm	in.	mm	in.	mm	lbs.	kg.
1/2	15	8 1/8	206	4 1/4	108	20	9
3/4	20	9 1/16	230	4 3/4	121	30	13.6
1	25	10 11/16	271	5 3/4	146	52	23
1 1/4	32	12	305	6 3/4	171	64.5	29
1 1/2	40	12	305	6 3/4	171	64.5	29
2	50	13 15/16	354	7 1/2	191	93	42
2 1/2	65	17 1/2	445	10 3/4	273	185	84
3	80	17 1/2	445	10 3/4	273	185	84
4	100	23 1/4	591	15	381	334	151
6	150	30 5/8	778	18 7/8	479	770	350
8	200	39	991	23 7/8	600	1200	545
10	250	CF	CF	CF	CF	CF	CF
12	300	CF	CF	CF	CF	CF	CF

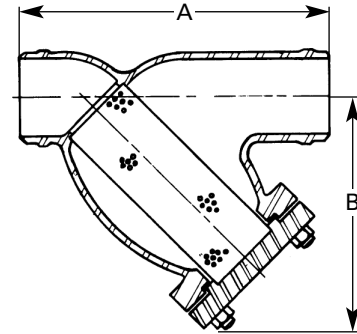

Models 765M-WE,  
766M-WE, 767-WE

SIZE		DIMENSIONS				WEIGHT	
		A		B			
in.	mm	in.	mm	in.	mm	lbs.	kg.
<b>767-WE</b>							
1/2	15	12 5/8	321	7 11/16	195	30	13.6
3/4	20	12 5/8	321	7 11/16	195	40	18
1	25	12 5/8	321	7 11/16	195	65	29.5
1 1/4	32	16 7/8	429	10 1/2	267	140	63.3
1 1/2	40	16 7/8	429	10 1/2	267	140	63.6
2	50	18 15/16	481	12 1/2	318	240	109
2 1/2	65	25 3/4	654	18 13/16	478	500	227
3	80	26 3/4	679	18 13/16	478	560	254
4	100	33 5/8	854	20 1/4	514	850	386
6	150	33 3/4	857	20	508	1900	862
8	200	CF	CF	CF	CF	CF	CF
10	250	CF	CF	CF	CF	CF	CF
12	300	CF	CF	CF	CF	CF	CF

Mueller Steam Specialty product specifications in U.S. customary units and metric are approximate and are provided for reference only. For precise measurements, please contact Mueller Steam Specialty Technical Service. Mueller Steam Specialty reserves the right to change or modify product design, construction, specifications, or materials without prior notice and without incurring any obligation to make such changes and modifications on Mueller Steam Specialty products previously or subsequently sold.



A Division of Watts Water Technologies, Inc.

USA: 1491 NC Hwy 20 West St. Pauls, NC 28384; www.muellersteam.com  
Tel: 910-865-8241 Fax: 910-865-6220  
Toll Free Phone 1-800-334-6259 Toll Free Fax: 1-800-421-6772