

# 175 PSI CWP Bronze Hose Gate Valves

Screw-in Bonnet • Non-Rising Stem • Solid Wedge

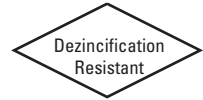

175 PSI/12.1 Bar Non-Shock Cold Working Pressure

CONFORMS TO MSS SP-80 •  
UL LISTED • FMRC APPROVED

### MATERIAL LIST

PART	SPECIFICATION
1. Handwheel Nut	Bronze ASTM B 16
2. Handwheel	Malleable Iron
3. Stem	Silicon Bronze ASTM B 371 Alloy C69400
4. Packing Nut	Bronze ASTM B 62
5. Packing Gland	Bronze ASTM B 16 or ASTM B 62
6. Packing	Non-Asbestos
7. Stuffing Box	Bronze ASTM B 62
8. Bonnet	Bronze ASTM B 62
9. Body	Bronze ASTM B 62
10. Wedge	Bronze ASTM B 62
11. Hose Cap	Bronze ASTM B 62
12. Hose Cap Gasket	Rubber
13. Safety Chain	Brass

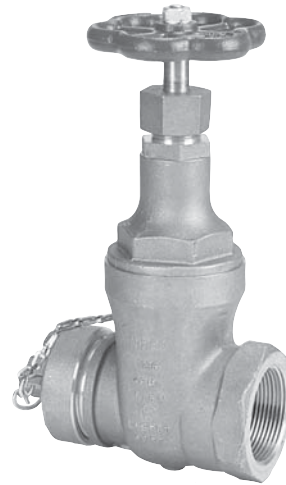

**T-103-HC**  
Threaded  
with Cap and Chain

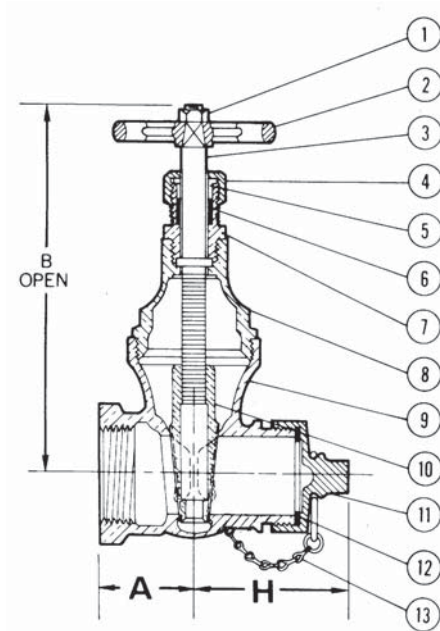

**T-103-HC**  
NPT x ANFH (NPPA)  
Hose 7.5 Threads Per Inch

### DIMENSIONS—WEIGHTS—QUANTITIES

#### Dimensions

Size	A		B		H		T-103-HC		Master Ctn. Qty.	
	In.	mm.	In.	mm.	In.	mm.	Lbs.	Kg.		
2½	65	3.00	76	11.38	289	4.75	121	18.5	8.40	2

**Freezing Weather Precaution** – Subsequent to testing a piping system, valves should be in an open position to allow complete drainage.