



Center Line has been a market leader in quarter-turn products for over 40 years. During this time, we have earned the reputation as a supplier of competitively priced valves of superior quality that exceed industry requirements and customer expectations.

We are committed to providing solutions that meet a wide range of applications and requirements. We continually improve our product line by introducing new products and enhancing existing designs, providing our customers with a unique marketplace advantage.

Our complete line of resilient seated butterfly valves provides you with the reliability you need, backed by the guarantee that comes with using valves designed and produced in company-owned manufacturing facilities.

## Series 225 Product Features

- Qualified for both gaseous and liquid service
- Positive shutoff bi-directionally
- Phenolic backed cartridge seat
- Three-position PTFE bushing standard
- One-piece thru shaft
- Locking handle standard
- End of line service optional
- Ease of automation
- Field repairable
- Complete size range: 2 through 24 inches

The Center Line Series 225 utilizes the same proven design features as our Series 200 but is rated to 285 psi. These design features include a phenolic-backed cartridge seat, precision profile disc, one-piece shaft, and four shaft support bearings. Series 225 heavy-duty butterfly valves are designed for the hostile operating conditions and high pressures encountered in many piping systems today. With the fully-lined body isolated from the flow stream, the use

of expensive alloys is limited to the disc and taper pins. Our Series 225 valves provide an excellent cost-effective alternative for ANSI Class 150 valves used in the following industries:

- HVAC/ATC
- Food and Beverage Industry
- Power and Utilities
- Pulp and Paper Industry

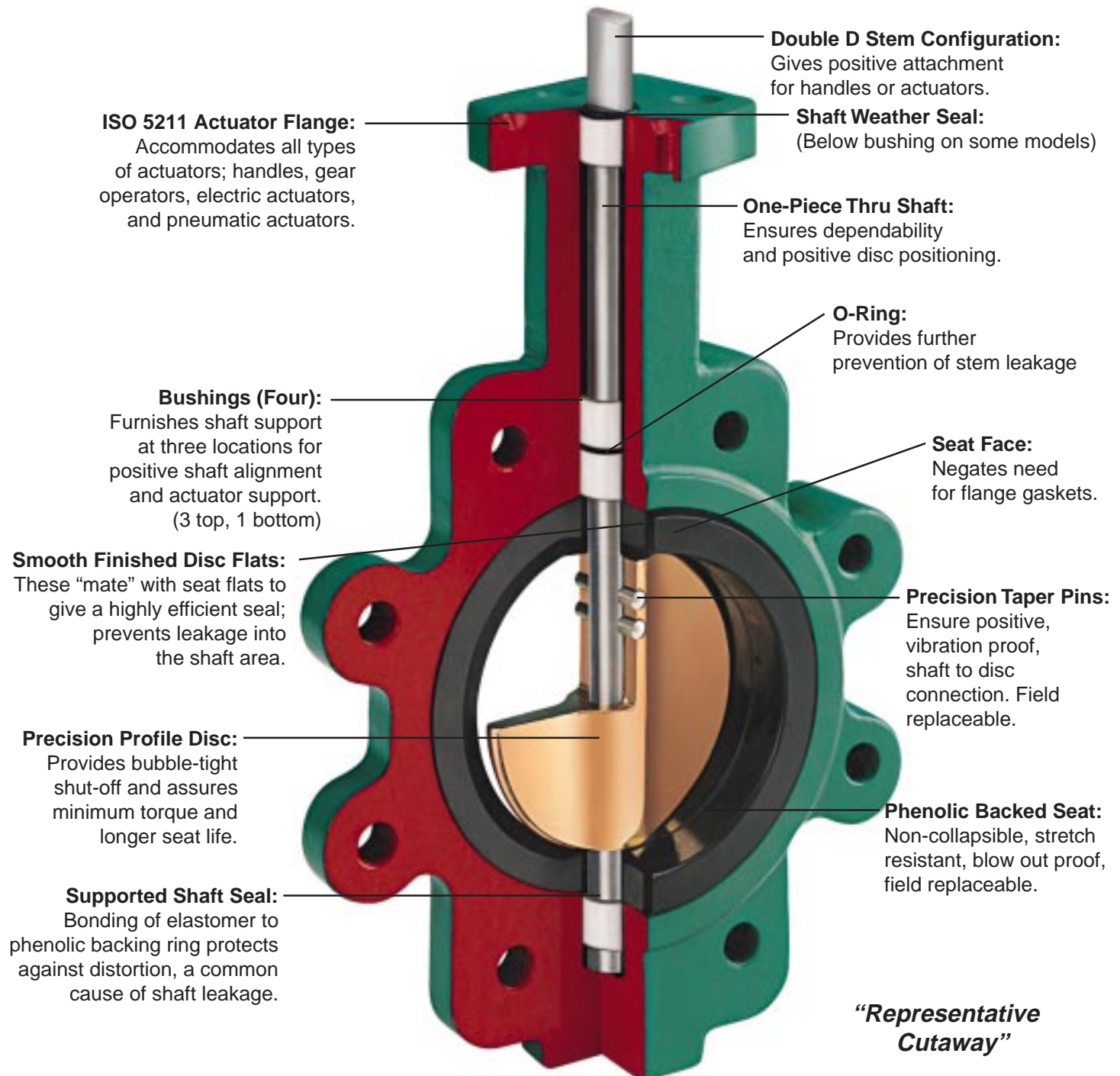

- Available in sizes 2" to 24".
- Pressure Rating: 285 psi at 100°F. Pressure/Temperature rating above 100°F corresponds to ANSI B16.5 Class 150 for steel flanges.
- Available in Wafer or Lug style body.
- Wafer body features four alignment holes.
- Available in ANSI Class 300 Lug Body bolt pattern (2"-12").
- Ideal for on-off or throttling services.

- Available with handles (2" to 6"), manual gear operators, electric actuators and pneumatic actuators (2" to 24").
- Refer to Crane actuator bulletins for details of pneumatic series 43000/48000 and electric series 44000 actuators.
- Compatible with ANSI B16.1 Class 125 (Iron) and ANSI B16.5 Class 150 (Steel) flanges or optional Class 300 (Steel) Lug only.
- Bi-directional dead-end capability to 200 psi (2" to 12") and 150 psi (14" to 24") is an available option.
- Valves 14" and larger are rated at a maximum 150 psi when a companion flange is not used in dead end service.

## Valve Seating Torques (In-Lbs.)

Valve Size	Standard Disc Differential Pressure				
	50 PSI	100 PSI	150 PSI	200 PSI	285 PSI
2"	136	142	148	154	164
2 1/2"	152	160	168	176	189
3"	224	229	234	239	247
4"	380	392	404	416	436
5"	451	477	503	529	572
6"	875	946	1016	1087	1206
8"	1476	1559	1642	1726	1867
10"	2451	2613	2775	2937	3213
12"	3900	4111	4323	4534	4893
14"	5189	5467	5744	6022	6494
16"	10,985	11,569	12,154	12,738	13,732
18"	13,946	14,688	15,431	16,173	17,434
20"	14,695	15,478	16,260	17,043	18,373
24"	29,738	31,321	32,903	34,486	37,176

Material	Temperature Rating °F
Buna-N	+10 to 180
EPDM (2"-16")	-30 to 275
EPDM (18"-24")	-30 to 225
Abrasive Resistant Buna-N	+10 to 180
Neoprene	+20 to 200
Hypalon	0 to 275
Viton®	+10 to 275
High Temperature Viton	+10 to 400

Seat materials are capable of withstanding lower temperatures without damage. However, the elastomer becomes hard and torques increase. Some flow media may further restrict the published temperature limits and/or significantly reduce seat life.

All torque values shown on chart are for "wet" (water and other non-lubricating media) on-off service. For "dry" service (non-lubricating, dry gas media), multiply values by 1.6. For "lubed" service (clean, non-abrasive lubricating media), multiply values by 0.85. When sizing actuators for single valve applications, multiply values by 1.25. When sizing for 3-way ("tee") applications multiply values by 1.5.

## C<sub>v</sub> Values – Valve Sizing Coefficients (US-GPM @ 1ΔP)

Size	10°	20°	30°	40°	50°	60°	70°	80°	90°
2"	0.06	3	7	15	27	44	70	105	115
2 1/2"	0.10	6	12	25	45	75	119	178	196
3"	0.20	9	18	39	70	116	183	275	302
4"	0.30	17	36	78	139	230	364	546	600
5"	0.50	29	61	133	237	392	620	930	1022
6"	0.80	34	94	153	257	422	706	1154	1320
8"	2	56	154	251	422	693	1158	1892	2165
10"	3	87	238	385	654	1073	1794	2931	3353
12"	4	153	417	681	1145	1879	3142	5132	5827
14"	6	183	500	816	1372	2252	3765	6150	7037
16"	8	271	740	1208	2031	3333	5573	9104	10,416
18"	11	318	867	1417	2382	3909	6535	10,676	12,215
20"	14	415	1133	1851	3112	5107	8538	13,948	15,959
24"	22	543	1482	2421	4069	6678	11,165	18,240	20,869

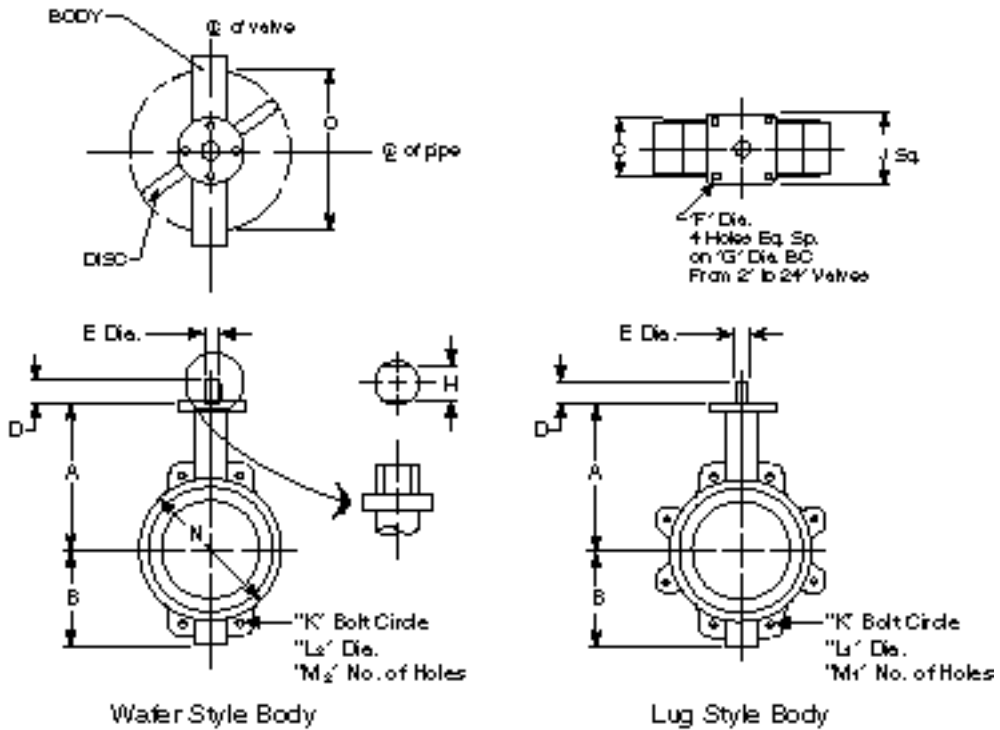

## Dimensions

Valve Size		A	B	C	D	E	F	G	H	J	K	300# K	L <sub>1</sub> *	300# L <sub>1</sub> *	L <sub>2</sub> *	M <sub>1</sub> *	300# M <sub>1</sub> *	M <sub>2</sub> *	WAFER	LUG	300# LUG	O	
2"	in.	6 3/8	3 1/4	1 3/4	1 1/4	1/2	3/8	2.76	0.39	2 3/4	4 3/4	5	3/8-11	3/8-11	1 1/8	4	8	4	6 lbs.	9 lbs.	9 lbs.	1.26	
50	mm	161.93	82.55	44.45	31.75	12.70	9.53	70	10	69.85	120.65	127.00	9.53	17.46	17.46	4	2.72 kg	4.09 kg	4.09 kg	32.0	13 lbs.	13 lbs.	1.83
2 1/2"	in.	6 7/8	3 3/4	1 7/8	1 1/4	1/2	3/8	2.76	0.39	2 3/4	5 1/2	5 7/8	3/8-11	3/4-10	1 1/8	4	8	4	7 lbs.	13 lbs.	13 lbs.	1.83	
65	mm	174.63	95.25	47.63	31.75	12.70	9.53	70	10	69.85	139.70	149.23	9.53	17.46	17.46	4	3.18 kg	5.90 kg	5.90 kg	46.5	14 lbs.	14 lbs.	2.54
3"	in.	7 1/8	4	1 7/8	1 1/4	1/2	3/8	2.76	0.39	2 3/4	6	6 3/8	3/8-11	3/4-10	1 1/8	4	8	4	10 lbs.	14 lbs.	14 lbs.	2.54	
75	mm	180.98	101.60	47.63	31.75	12.70	9.53	70	10	69.85	152.40	168.28	9.53	17.46	17.46	4	4.54 kg	6.36 kg	6.36 kg	64.5	19 lbs.	19 lbs.	3.54
4"	in.	7 7/8	4 1/8	2 1/8	1 1/4	5/8	3/8	2.76	0.47	2 3/4	7 1/2	7 7/8	3/8-11	3/4-10	1 1/8	8	8	4	13 lbs.	19 lbs.	24 lbs.	3.54	
100	mm	200.03	123.83	53.98	31.75	15.88	9.53	70	14	69.85	190.50	200.03	9.53	17.46	17.46	8	5.90 kg	8.63 kg	10.90 kg	89.9	24 lbs.	24 lbs.	4.36
5"	in.	8 3/8	5 3/8	2 1/4	1 1/4	3/4	3/8	2.76	0.55	2 3/4	8 1/2	9 1/4	3/4-10	3/4-10	1 3/8	8	8	4	18 lbs.	22 lbs.	29 lbs.	4.36	
125	mm	212.73	136.53	57.15	31.75	19.05	9.53	70	17	69.85	215.90	234.95	9.53	20.64	20.64	8	8.17 kg	9.99 kg	13.17 kg	110.7	29 lbs.	29 lbs.	5.74
6"	in.	8 7/8	5 7/8	2 1/4	1 1/4	3/4	3/8	2.76	0.55	2 3/4	9 1/2	10 3/8	3/4-10	3/4-10	1 3/8	8	12	4	21 lbs.	31 lbs.	38 lbs.	5.74	
150	mm	225.43	149.23	57.15	31.75	19.05	9.53	70	17	69.85	241.30	269.88	9.53	20.64	20.64	8	9.53 kg	14.07 kg	17.25 kg	145.8	38 lbs.	38 lbs.	7.63
8"	in.	10 1/4	7 3/4	2 1/2	1 3/4	7/8	7/16	4.02	0.67	3 3/4	11 3/4	13	3/4-10	7/8-9	1 3/8	8	12	4	34 lbs.	49 lbs.	67 lbs.	7.63	
200	mm	260.35	196.85	63.50	44.45	22.23	11.11	102	22	95.33	298.45	330.20	9.53	20.64	20.64	8	15.44 kg	22.25 kg	30.42 kg	193.8	67 lbs.	67 lbs.	11.5
10"	in.	11 1/2	8 1/4	2 3/4	1 3/4	1 1/8	7/16	4.02	0.87	3 3/4	14 1/4	15 1/4	7/8-9	1-8	1 3/8	12	16	4	45 lbs.	72 lbs.	100 lbs.	9.54	
250	mm	292.10	209.55	69.85	44.45	28.58	11.11	102	24	95.33	361.95	387.35	9.53	23.81	23.81	12	20.43 kg	32.69 kg	45.40 kg	242.3	100 lbs.	100 lbs.	11.5
12"	in.	13 1/4	9 3/4	3 1/8	1 3/4	1 1/4	7/16	4.02	0.95	3 3/4	17	17 3/4	7/8-9	1 1/8-7	1 3/8	12	16	4	74 lbs.	105 lbs.	144 lbs.	11.5	
300	mm	336.55	247.65	79.38	44.45	31.75	11.11	102	24	95.33	431.80	431.80	9.53	23.81	23.81	12	33.60 kg	47.67 kg	65.38	292.1	144 lbs.	144 lbs.	11.5
14"	in.	14 1/2	11	3 1/8	1 3/4	1 1/4	7/16	6.50	0.95	3 3/4	18 3/4	-	1-8	-	12	-	109 lbs.	178 lbs.	-	12.81	-	-	-
350	mm	368.30	279.40	79.38	44.45	31.75	11.11	165	24	95.33	476.25	-	1-8	-	16	49.49 kg	80.81 kg	325.4	12.81	-	-	-	
16"	in.	15 3/4	12	3 1/2	2	1 5/16	7/8	6.50	1.06	6 1/2	21 1/4	-	1-8	-	16	-	135 lbs.	224 lbs.	-	15	-	-	-
400	mm	400.05	304.80	88.90	50.80	33.34	22.23	165	27	165.10	539.75	-	1-8	-	16	61.29 kg	101.70 kg	381.0	15	-	-	-	
18"	in.	16 3/8	15	4 1/4	2	1 3/8	7/8	6.50	1.26	6 1/2	22 3/4	-	1 1/8-7	-	16	-	190 lbs.	265 lbs.	-	16.87	-	-	-
450	mm	422.28	381.00	107.95	50.80	41.28	22.23	165	32	165.10	577.85	-	1 1/8-7	-	16	86.27 kg	120.31 kg	428.5	16.87	-	-	-	
20"	in.	18 7/8	15 1/4	5 1/16	2 1/2	1 5/8	7/8	6.50	1.26	6 1/2	25	-	1 1/8-7	-	20	-	316 lbs.	455 lbs.	-	18.69	-	-	-
500	mm	479.43	387.35	128.95	63.50	41.28	22.23	165	32	165.10	635.00	-	1 1/8-7	-	20	143.47 kg	206.57 kg	474.7	18.69	-	-	-	
24"	in.	22 1/8	18	6 1/8	2 3/4	3	7/8	6.50	2.36	6 1/2	29 1/2	-	1 1/4-7	-	20	-	506 lbs.	702 lbs.	-	22.57	-	-	-
600	mm	561.98	457.20	155.58	69.85	76.20	22.23	165	60	165.10	749.30	-	1 1/4-7	-	20	229.74 kg	318.71 kg	573.3	22.57	-	-	-	

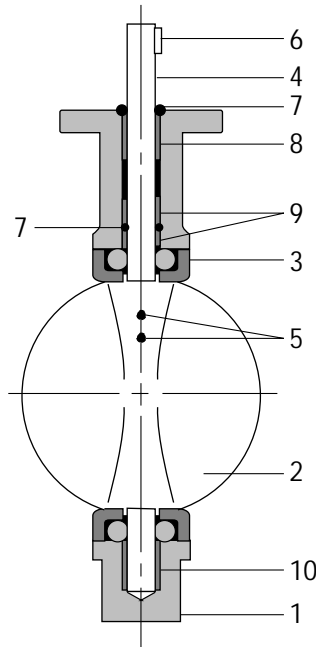

## Bill of Materials 2" - 30"

Item	Description	Materials	Optional Materials
1	Body	Ductile Iron	No Options Available
2	Disc	Ductile Iron <sup>1</sup>	Aluminum Bronze, 316 Stainless Steel, Monel
3	Seat	Buna-N or EPDM	Neoprene, Hypalon, Abrasive Resistant Buna-N, Low Temperature Viton (2"-24"), High Temperature Viton (2"-12")
4	Shaft	416 Stainless Steel	2"-12": 17-4 PH, Monel
5	Taper Pin	316 Stainless Steel	Monel
6	Key	Carbon Steel	No Option Available
7	O-Ring	Buna-N	No Option Available
8	Bushing	PTFE	No Option Available
9	Bushing	PTFE	No Option Available
10	Bushing	PTFE	No Option Available

<sup>1</sup>ENP plated for 2" - 12" valves

## CENTER LINE FIGURE NUMBER SYSTEM

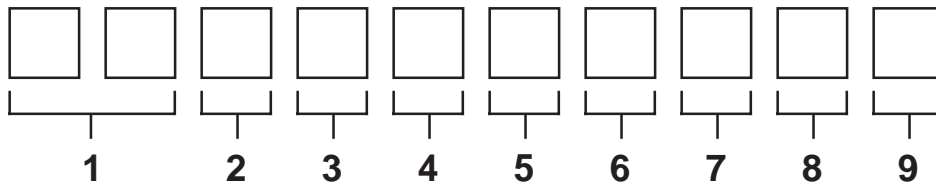

1. Size	Code
2"	02
2.5"	25
3"	03
To	
24"	24

2. Series/Style	Code
225-Wafer	J
225-Lug	K
225-Lug/Deadend (DES)*	L
225-Lug/ANSI Bolt Pattern	M
225-Lug/Deadend/ANSI 300*	N

3. Body	Code
Ductile Iron	2

4. Pressure	Code
200 PSI (2" - 12" DES)	0
285 PSI (Standard)	5
150 PSI (14" - 24" DES)	6
125 PSI (2" - 24" w/PTFE/Buna)	8

5. Disc	Code
Ductile Iron	2
316 SS	4
Aluminum Bronze	6
Monel	7

6. Shaft	Code
416 SS	1
316 SS**	4
Monel	7
17-4 PH	9

7. Bushing	Code
PTFE	3

8. Seat/Liner	Code
Buna	1
Abrasion Resistant Buna	2
Black Neoprene	3
White Neoprene	4
EPDM	5
Low Temp Viton (275 F)	6
Hypalon	7
Perox. Cured Buna	8
White Buna	B
Potable Water EPDM	D
PTFE/Buna**	L
High Temp Viton (400 F)	P
EPDM Food Grade	V
White Buna Food Grade	W

9. Actuator	Code
Handle (DIT)	2
Handle/Infinite Adjustment	3
Lockable (DIT/IOL)	
Handle/Infinite Adjustment (DIT/IO)	4
Gear/Handwheel	5
Pneumatic, Double Acting	6
Pneumatic, Spring Return, Fail Closed	7
Pneumatic, Spring Return, Fail Open	8
Electric Actuator	9
Buried Service Gear	C
Direct Nut Actuator	D
Gear w/Balance Stop Handwheel	G
Gear/Chainwheel	U
No Operator	X

= Center Line Series 225 standard configuration

\* = 2"-12" maximum rating is 200 psi for DES

= 14"-24" maximum rating is 150 psi for DES

\*\* = 125 psi shutoff maximum rating for PTFE/Buna seat.