

Models: 125F-CI*, 125F-B

Cast Iron or Cast Bronze Flanged End Basket Type Strainers

Sizes: 3/4" - 18" (10-450mm)

Pressure / Temperature – Non-Shock		
Model	Material	Rating
125F-CI 3/4"-12"	Cast Iron	200psi @ -20°F to 150°F
		13.79 bar @ 65.56°C
		190psi @ 200°F
125F-CI 14"-18"	Cast Iron	150psi @ -20°F to 150°F
		10.34 bar @ 65.56°C
		125psi @ 250°F
125F-B 3/4"-18"	Bronze	8.62 bar @ 121.11°C
		225psi @ -20°F to 150°F
		15.51 bar @ 65.56°C
		210psi @ 200°F
		14.48 bar @ 93.33°C

All units rate 200psi with knob type closure

125F-CI Cast Iron **Class 125**

125F-B Bronze **Class 150**



Model 125F

Strainers provide economical protection for costly pumps, meters, valves, and othersimilar mechanical equipment by straining foreign matter from the connected piping system. Installation of a strainer before mechanical equipment can ensure trouble free service and avoid costly shutdowns for repair or replacement of equipment damaged by foreign matter. The size of the perforation or mesh in the basket screen will determine the smallest particles captured. See Strainer Information section in the Mueller Steam Specialty Engineering binder for detailed information including sizes and materials available.

Typical Service

- These strainers can be specified for cooling water, seawater, hot water systems and more.

Features

- Designed for large capacity straining and ease of maintenance.
- Cover is secured with quick-opening knobs to minimize service time.
- O-ring seals on both the cover and baskets can usually be reused after service, no need to clean gasket residue and replace costly gaskets.
- Machined basket seat eliminates particle bypass.

Construction

- Standard cover has O-ring seal and quick release knob fasteners up to 8" size, bolted cover for sizes 10" and up.
- Bolted cover available for all sizes, consult factory
- Swing clamp covers are available, consult factory
- Plugged NPT connection is provided at location D. See next page.

Capacity

- Minimum 6 to 1 ratio

Galvanizing

- Available on cast iron models. Other coatings are available on application.

Baskets

MODEL	SIZES	STANDARD (WATER)		STEAM RECOMMENDATION	
		MATERIAL	OPENING	MATERIAL	OPENING
125F-CI, 125F-B	3/4"- 4"	304SS	.062 perf	304SS	.062 perf
125F-CI, 125F-B	5"-18"	304SS	.125 perf	304SS	.125 perf

Material

	125F-CI	125F-B
Body	Cast Iron ASTM A126-B	Bronze ASTM B62 (Type 85-5-5-5)
Cover	Cast Iron ASTM A126-B	Bronze ASTM B62 (Type 85-5-5-5)
O-Ring	Buna-N	Buna-N

Pressure Drop

See Pressure Drop Charts in Technical Data section of the Mueller Steam Engineering binder.

*125F supersedes Model 195.
195 still available upon request.

Dimensions and Weights

SIZE		DIMENSIONS								WEIGHT					
		A		B		C		D (NPT)		E Screen Removal		Cast Iron		Bronze	
in.	mm	in.	mm	in.	mm	in.	mm	in.	mm	in.	mm	lbs.	kgs.	lbs.	kgs.
3/4	20	5 11/16	145	4 11/16	119	2 3/4	70	3/8	10	5 7/8	150	9	4	11	5
1	25	5 11/16	145	4 11/16	119	2 3/4	70	3/8	10	5 7/8	150	9	4	11	5
1 1/4	32	6 15/16	176	6 1/2	165	3	76	1/2	15	8 1/8	206	15	6.8	18	8
1 1/2	40	6 15/16	176	6 1/2	165	3	76	1/2	15	8 1/8	206	15	6.8	18	8
2	50	9	229	7 7/8	200	3 3/8	92	3/4	20	10 1/8	257	26	11	31	14
2 1/2	65	10 3/8	264	8 3/4	222	4	102	1	25	11 1/16	291	38	17	45	20
3	90	11 3/4	298	11 3/8	289	4 1/2	114	1	25	14 13/16	376	62	28	72	32
4	100	15	381	15 7/8	403	5 3/4	146	2	50	19 7/8	505	118	53.6	147	66
5	125	18 3/8	467	18 3/8	467	7 7/16	189	1 1/2	40	25 5/16	650	170	77	210	95
6	150	20 1/4	514	22 3/8	568	8 3/16	208	2	50	29 1/8	740	266	120	315	143
8	200	27 3/8	695	27 3/4	705	9 3/16	233	2	50	29 1/8	943	518	235	553	251
10	250	29 1/2	749	35 5/16	897	12 1/16	316	2	50	50 13/16	1291	1134	515	CF	CF
12	300	33 3/4	857	43 7/8	1114	10 3/4	273	2	50	61 1/4	1556	1200	544	CF	CF
14	350	47 7/8	1197	34 3/8	873	20 5/8	524	2	50	69	1753	1725	784	CF	CF
16	400	47 7/8	1197	34 3/8	873	20 1/16	510	2	50	69	1753	2100	954	CF	CF
18	450	49 1/2	1257	58	1381	16	406	2	50	82	2083	2850	1295	CF	CF

CF - Consult Factory. Apply for Certified Drawings.

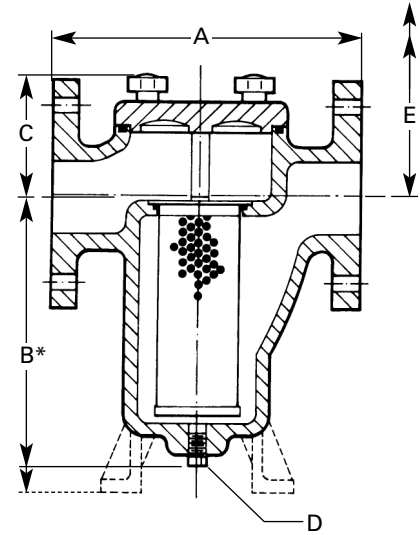

Model 125F

* "B" dimension includes the floor supports on 4" size and larger

Mueller Steam Specialty product specifications in U.S. customary units and metric are approximate and are provided for reference only. For precise measurements, please contact Mueller Steam Specialty Technical Service. Mueller Steam Specialty reserves the right to change or modify product design, construction, specifications, or materials without prior notice and without incurring any obligation to make such changes and modifications on Mueller Steam Specialty products previously or subsequently sold.



A Division of Watts Water Technologies, Inc.

USA: 1491 NC Hwy 20 West St. Pauls, NC 28384; www.muellersteam.com

Tel: 910-865-8241 Fax: 910-865-6220

Toll Free Phone 1-800-334-6259 Toll Free Fax: 1-800-421-6772