

NIBCO® Press System® Bronze Ball Valves

Two-Piece Body • Full Port • 316 SS Ball & Stem • NIB-SEAL® Handle



600 PSI/41.4 Bar Non-Shock Cold Working Pressure
250°F Maximum Operating Temperature
Nominal sizes 1/2" through 1" are UL certified to NSF/ANSI 61

CONFORMS TO MSS SP-110

MATERIAL LIST

PART	SPECIFICATION
1. Cap	Plastic
2. Insulation	Styrofoam
3. Extension Handle	Plastic
4. Sleeve	Clear Plastic
5. Handle Nut	Zinc Plated Steel
6. Screw	Zinc Plated Steel
7. Memory Stop Plate	Zinc Plated Steel
8. Base Plate	Zinc Plated Steel
9. Thread Pack Gland	Brass ASTM B 16 Alloy C36000
10. Packing	PTFE
11. Stem	ASTM A 276 Alloy S31600 Stainless Steel
12. Body End	Bronze ASTM B 584 Alloy C84400
13. Thrust Washer	RTFE
14. Ball	ASTM A 276 Alloy S31600 Stainless Steel
15. Seat Ring (2)	Reinforced TFE
16. Body	Bronze ASTM B 584 Alloy C84000
17. Stub Out (2)	Type "L" Copper Tube

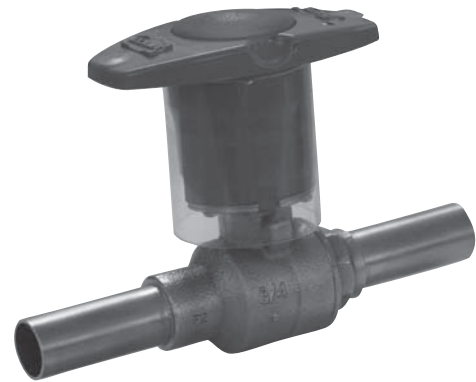

PS58570-66-NS

Press x Press
Male End

DIMENSIONS—WEIGHTS

Size	Dimensions				Weight						
	A	C	E	F	Lbs.	Kg.					
1/2	15	6.56	167	3.75	95	2.19	56	4.25	108	.97	.44
3/4	20	7.25	184	4.00	101	2.19	56	4.25	108	1.74	.79
1	25	7.75	197	4.25	108	2.19	56	4.25	108	2.29	1.04
1 1/4	32	9.06	230	5.38	137	3.38	86	6.50	165	4.33	1.97
1 1/2	40	9.99	254	5.56	141	3.38	86	6.50	165	6.26	2.84
2	50	10.72	272	5.88	149	3.38	86	6.50	165	9.31	4.22

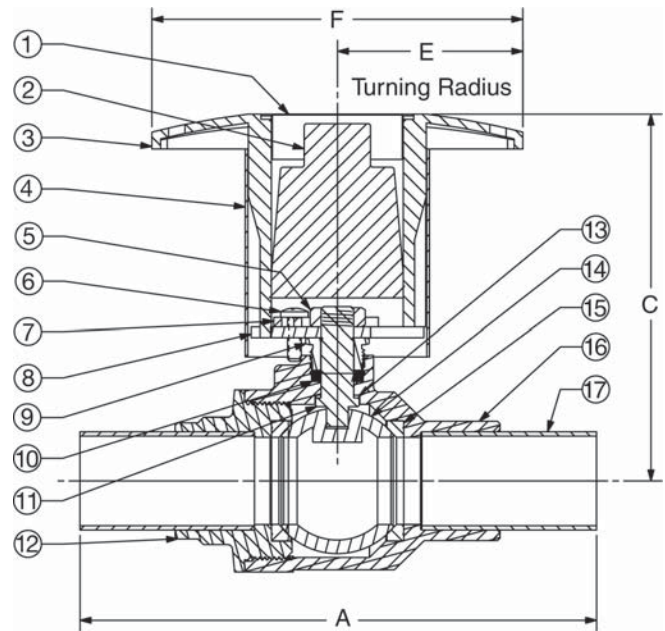

PS585-70-66-NS

P x P

NIBCO® Press System® ball valves are designed to meet MSS SP-110 with the exception of the end connection. Ball valves are down-rated from 600 PSI CWP to 200 PSI CWP to match the Press System®. Male and female press-to-connect ends are new technology not yet covered in the current edition of this specification.