



7 Series—Fire Safe

2-way, 3-piece Bolted Ball Valves

HOKE's 7 Series Fire Safe Valves meet demanding application requirements in the production environment of chemical and petrochemical processing facilities. These valves have been tested to and meet the requirements of API 607, 4th edition for soft-seated valves. API 607 measures the ability of a closed soft-seated ball valve to retard the propagation of a fire (downstream and to atmosphere). The 7 Series Fire Safe Valves offer high flow, safety, and flexibility in a variety of end connections and sizes. This series is available in fractional sizes from ½" to 1" and in metric sizes from 12mm to 25mm in tube and pipe ends.



Typical Applications

- Chemical processing
- Petroleum refining
- Gas distribution
- Hydraulic fluids

Technical Data

BODY MATERIAL*	316 stainless steel, grade CF8M
MAXIMUM OPERATING PRESSURE	1500 psig @ 70° F (103 bar @ 21° C)
OPERATING TEMPERATURE RANGE	-40° F to +500° F (-40° C to +260° C)
ORIFICE SIZE	0.28" to 0.88" (7.1mm to 22.3mm)
Cv FACTORS	4.5 to 38
END CONNECTIONS	Gyrolok® tube fittings, female NPT, tube socket weld, pipe socket weld, pipe butt weld

* Consult factory for other materials

Features & Benefits

- Bottom-loaded stem prevents stem blowout for added safety.
- Fully encapsulated bolts are protected from the environment, extending valve life and reducing costs.
- Optional trip-proof or latching/locking handle prevents accidental opening or closing of the valve for a secure process.
- Optional fuse plugs are available on actuators for added safety.
- Fire-safe design retards the propagation of a fire downstream or to the atmosphere, enhancing safety and increasing the range of possible applications.
- Handle provides a visual indicator of whether valve is in the open or closed position, enhancing safety.
- Stem flats provide visual indication of valve position, improving safety.
- Actuators can be mounted to valves without disrupting the packing, seats or seals. Installation time and costs are minimized.
- Special High Tolerance NPT Thread

HOKE Incorporated

405 Centura Court • PO Box 4866 (29305) • Spartanburg, SC 29303
Phone (864) 574-7966 Fax (864) 587-5608
www.hoke.com • sales@hoke.com

ball valves

7 Series – Fire Safe

Materials of Construction

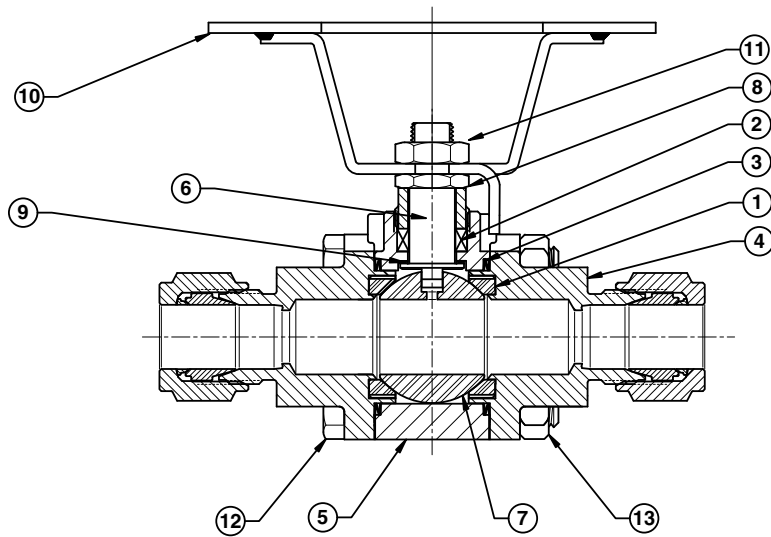

#	DESCRIPTION	MATERIAL
1	Seat*	PTFE**
2	Packing*	Grafoil®
3	Body seal*	316 stainless steel, PTFE coated
4	End plate*	316 stainless steel, grade CF3M
5	Body*	316 stainless steel, grade CF8M
6	Stem*	316 stainless steel
7	Ball*	316 stainless steel
8	Packing nut	316 stainless steel
9	Thrust washer*	PTFE or PEEK™
10	Handle	316 stainless steel
11	Stem nut	316 stainless steel
12	Body bolt	316 stainless steel
13	Body nut	316 stainless steel

Other materials available upon request.

* Wetted Components

** PTFE seat is modified to reduce cold flow and increase durability without losing inert property.

Pressure vs. Temperature Chart

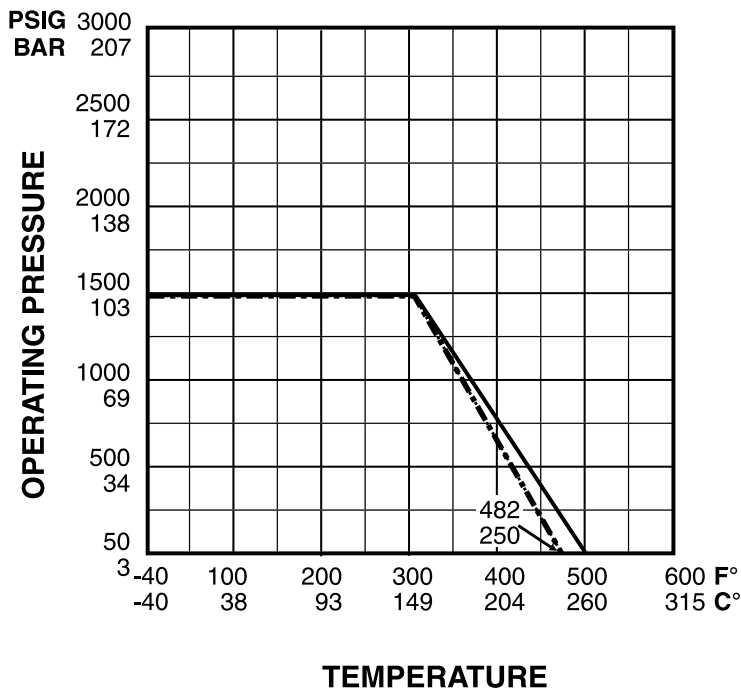

TEMPERATURE

----- PEEK® Seat

———— PTFE Seat

SEAT	BODY SEAL	PACKING	THRUST WASHER
T PTFE*	Stainless steel PTFE coated	Grafoil®	PTFE
P PEEK™	Stainless steel PTFE coated	Grafoil®	PEEK™

* PTFE seat is modified to reduce cold flow and increase durability without losing inert property

Flow Diagrams – 2-way valve

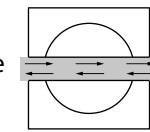
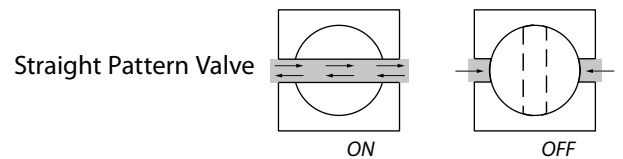

ON

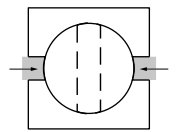

OFF

7 Series – Fire Safe

Dimensions

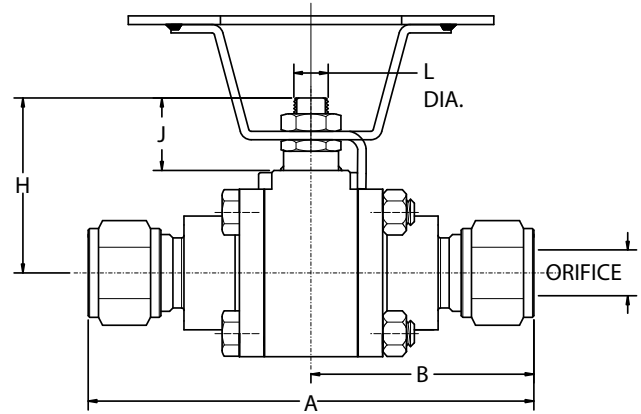
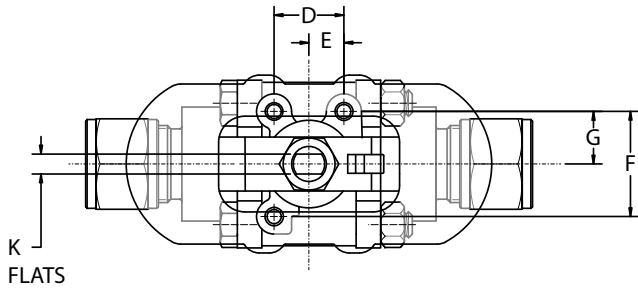

7EF Series (C_v Range 4.5 - 12.5)

END CONNECTION	ORIFICE	C _v	A	B	D	E	F	G	H	J	K	L
3/8" Gyrolok®	0.30"	4.5	3.31"	1.70"								
1/2" Gyrolok®	0.42"	7.5	3.80"	1.90"								
3/4" Gyrolok®	0.50"	12.5	3.80"	1.90"								
12mm Gyrolok®	0.39"	7.0	3.80"	1.90"								
18mm Gyrolok®	0.50"	12.5	3.80"	1.90"								
3/8" FNPT sch 80	0.50"	12.5	3.25"	1.67"								
1/2" FNPT sch 80	0.50"	15	3.25"	1.67"								
3/8" tube socket weld	0.30"	4.5	2.36"	1.18"	0.73"	0.37"	0.35"	0.43"	1.54"	0.59"	0.19"	0.31"
1/2" tube socket weld	0.42"	7.5	2.36"	1.18"	18.5mm	9.4mm	8.9mm	10.9mm	39.1mm	15.0mm	4.8mm	7.9mm
3/4" tube socket weld	0.50"	12.5	2.36"	1.18"								
12mm tube socket weld	0.42"	7.5	2.36"	1.18"								
18mm tube socket weld	0.50"	12.5	2.36"	1.18"								
3/8" pipe socket weld sch 80	0.50"	12.5	2.36"	1.18"								
1/2" pipe socket weld sch 80	0.50"	12.5	2.36"	1.18"								
3/8" pipe butt weld sch 80	0.42"	7.5	2.10"	1.05"								
1/2" pipe butt weld sch 80	0.50"	12.5	2.10"	1.05"								

7FF Series (C_v Range 27 - 38)

END CONNECTION	ORIFICE	C _v	A	B	D	E	F	G	H	J	K	L
1" Gyrolok®	0.88"	38	5.60"	2.80"								
25mm Gyrolok®	0.88"	38	5.60"	2.80"								
3/4" FNPT sch 80	0.88"	38	3.69"	1.85"								
1" FNPT sch 80	0.88"	38	3.69"	1.85"								
1" tube socket weld	0.88"	38	3.45"	1.73"	1.00"	0.50"	1.50"	0.75"	2.20"	0.80"	0.28"	0.50"
25mm tube socket weld	0.88"	38	3.45"	1.73"	25.4 mm	12.7mm	38.1mm	19.1mm	55.9mm	20.3mm	7.1mm	12.7mm
3/4" pipe socket weld sch 80	0.88"	38	3.45"	1.73"								
1" pipe socket weld sch 80	0.88"	38	3.45"	1.73"								
3/4" pipe butt weld sch 80	0.75"	27	3.45"	1.73"								
1" pipe butt weld sch 80	0.88"	38	3.45"	1.73"								

Note: Orifice dimension and C_v are listed for the total valve.
Dimensions for reference only, subject to change.

7 Series – Fire Safe

How to Order

Standard items in bold.

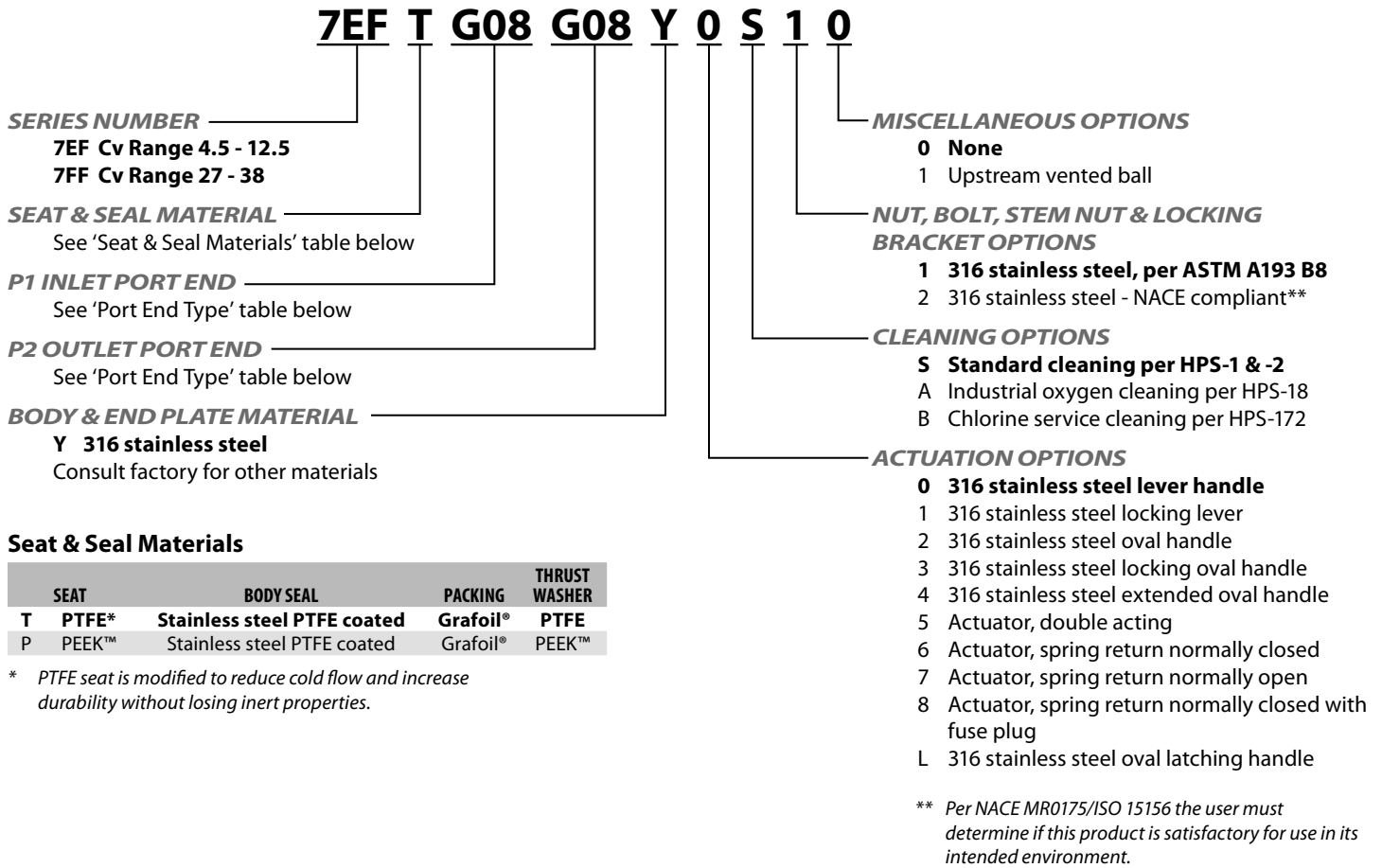

Seat & Seal Materials

	SEAT	BODY SEAL	PACKING	THRUST WASHER
T	PTFE*	Stainless steel PTFE coated	Grafoil®	PTFE
P	PEEK™	Stainless steel PTFE coated	Grafoil®	PEEK™

* PTFE seat is modified to reduce cold flow and increase durability without losing inert properties.

P1 Inlet / P2 Outlet Ports End Type

SERIES	SIZE	GYROLOK®	FEMALE NPT	TUBE SOCKET WELD	PIPE SOCKET WELD	PIPE BUTT WELD
7EF	3/8"	G06	F06	T06	P06	B06
	1/2"	G08	F08	T08	P08	B08
	3/4"	G12	—	T12	—	—
	12mm	Z12	—	W12	—	—
	18mm	Z18	—	W18	—	—
7FF	3/4"	—	F12	—	P12	B12
	1"	G16	F16	T16	P16	B16
	25mm	Z25	—	W25	—	—

Cleaning Options

- HPS-1** Cleaning procedure to remove oil and grease from metal valve parts with solvent vapor- and solvent ultrasonic vapor degreasers.
- HPS-2** Cleaning procedure to remove dirt, oil, and grease from non-metallic parts with non-ionic detergent and water solution.
- HPS-18** Cleaning procedure to remove oil, grease, and other contaminants from the valve and fitting components prior to assembly for industrial oxygen service.
- HPS-172** Procedure to clean and package valve parts and assemblies for use with dry chlorine gas or liquid.

** Per NACE MR0175/ISO 15156 the user must determine if this product is satisfactory for use in its intended environment.