

Cylinder Valves

2400 Series 1/2" Cylinder Valves



2464L84Y
with rupture disc

2400 Series 316 stainless steel, forged body angle pattern valves, come with a union bonnet for increased safety and ease of maintenance.

Available with pressure rupture discs or spring relief devices as an integral part of the valve.

Features

- Forged body union bonnet design for ease of maintenance and maximum reliability
- Non-rotating hardened 17-4PH stainless steel tip prevents galling and extends valve life
- Dyna-Pak packing below stem threads prevents lubricant washout & contamination of process fluids
- Stem backseat provides added safety
- Available with integral rupture disc or spring relief

Technical Data

MAXIMUM OPERATING PRESSURE	5000 psig [345 barg]
TEMPERATURE RANGE	Metal stem tip: -40° F to +350° F (-40° C to +177° C) TFE stem tip: -20° F to +250° F (-29° C to +121° C) All burst discs & spring relief devices: -20° F to +250° F (-29° C to +121° C)
ORIFICE SIZE	0.312
Cv FACTOR	2.2

Materials of Constructions

BODY & BONNET	316SS
STEM	17-4PH
THREAD GLAND	416SS
PACKING NUT	303SS
RING GLAND	303SS



2466L84Y
with spring relief



2462L84Y

Cylinder Valves

Valves with Rupture Discs

INLET	OUTLET	ORDER BY PART NUMBER		ADD CODE LETTER	RUPTURE DISC KITS
		TEFLON® PACKING			
		TEFLON® STEM TIP	METAL STEM TIP		
1/2 NGT Male	1/4 NPT Female	2464L84Y	2424L84Y	D 1400–1600 psi	SP6712K1
				G 1800–2000 psi	SP6712K2
				E* 2600–3000 psi	SP6712K3
				F 3500–4100 psi	SP6712K4**
				H 5400–6200 psi	SP6712K5**

* Normally supplied with DOT 3E-1800 and DOT 3A-1800

** Special order only. Please contact Hoke factory.

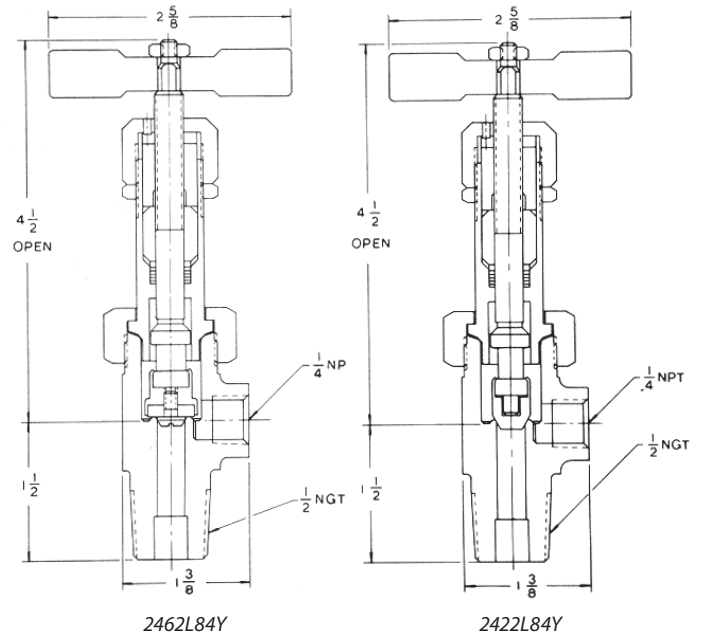

Valves without Relief Devices

INLET	OUTLET	ORDER BY PART NUMBER	
		TEFLON® PACKING	
		TEFLON® STEM TIP	METAL STEM TIP
1/2 NGT Male	1/4 NPT Female	2462L84Y	2422L84Y

Valves with Spring Relief Devices

INLET	OUTLET	ORDER BY PART NUMBER		ADD CODE LETTER
		TEFLON® PACKING		
		TEFLON® STEM TIP	METAL STEM TIP	
1/2 NGT Male	1/4 NPT Female	2466L84Y	2426L84Y	C 350–400 psi
				D* 540–600 psi

* Normally supplied with DOT 38-400

Ordering Instructions for Valves with Relief Devices

1. Determine whether the relief range you require is served by a spring relief or a rupture disc model.
2. Order by part number, followed by code of the desired range. For example: No. 2424L84YD.

