

Class 125 Iron Body Check Valves

Bolted Bonnet • Horizontal Swing • *Renewable Seat and Disc

125 PSI/8.6 Bar Saturated Steam to 353° F/178° C
200 PSI/13.8 Bar Non-Shock Cold Working Pressure
to -20° F to 150° F/-29° C to 66° C

CONFORMS TO MSS SP-71 TYPE 1

MATERIAL LIST

PART	SPECIFICATION
1. Body Bolt	Steel ASTM A 307
2. Identification Plate	Aluminum
3. Bonnet	Cast Iron ASTM A 126 Class B
4. Body Gasket	Synthetic Fibres
5. Body Nut	Steel ASTM A 307
6. Side Plug	Brass ASTM B 16 Alloy C36000
7. Hanger Pin	Brass ASTM B 16 Alloy C36000
8. ² Hanger	Cast Bronze ASTM B 584 Alloy C84400
9. ¹ Disc	Cast Bronze ASTM B 584 Alloy C84400 or ASTM A 536 Ductile Iron with Bronze Face Ring
10. Seat Ring	Cast Bronze ASTM B 584 Alloy C84400
11. Disc Nut	Brass ASTM B 16 Alloy C36000
12. Body	Cast Iron ASTM A 126 Class B
13. ¹ Disc Bolt	Brass ASTM B 16 Alloy C36000
14. Disc Plate	Cast Iron ASTM A 126 Class B
15. Disc Cage	Cast Iron ASTM A 126 Class B

¹ 2" thru 4" have Bronze ASTM B 62 Disc.

⁵ thru 12" have Iron Disc with Bronze Disc Face Rings and Disc Bolt.

² 10" is Ductile Iron ASTM A 536.



F-918-B
Flanged



T-918-B
Threaded

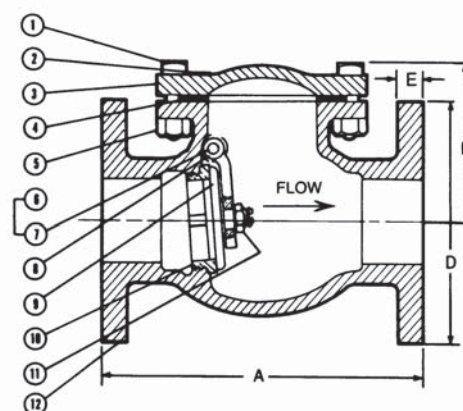

F-918-B
Flg x Flg

DIMENSIONS—WEIGHTS—QUANTITIES

Size	Dimensions										F-918-B		T-918-B		
	F-918-B		T-918-B		B		D		E		Lbs.	Kg.	Lbs.	Kg.	
In.	mm.	In.	mm.	In.	mm.	In.	mm.	In.	mm.	In.	mm.				
2	50	8.00	203	6.50	165	3.94	100	6.00	152	.63	16	24	11	15	7
2½	65	8.50	216	7.50	191	4.50	114	7.00	178	.69	17	35	16	26	12
3	80	9.50	241	8.00	203	5.13	130	7.50	191	.75	19	47	21	31	14
4	100	11.50	292	9.38	238	6.13	156	9.00	229	.94	24	80	36	54	24
5	125	13.00	330	10.63	270	6.81	173	10.00	254	.94	24	100	45	80	36
6	150	14.00	356	12.25	311	8.00	203	11.00	279	1.00	25	146	66	121	54
8	200	19.50	495	x	x	9.44	240	13.50	343	1.13	29	274	124	x	x
10	250	24.50	622	x	x	12.06	306	16.00	406	1.19	30	426	193	x	x
12	300	27.50	699	x	x	16.13	410	19.00	483	1.25	32	675	306	x	x

Note: On pump discharge, the preferred check valves are one of the following types: "in-line spring loaded or swing design with lever and weight or with lever and spring." You should also install the check valve as far from the pump as possible and at a minimum length of 5 times the pipe diameter. Flow straighteners may be required.

* Proper machining facilities required.

x Not available this size.

2½" thru 12" are available with lever and weight or lever and spring.

Swing Check valves should be sized for a 0.50 PSI pressure drop.

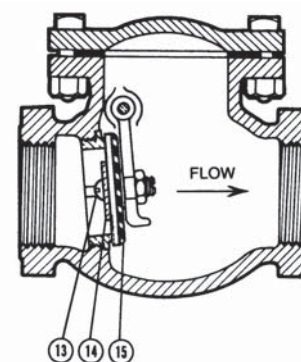

T-918
NPT x NPT

WARNING: Do not use for Reciprocating Air Compressor Service.

NIBCO Iron Body Check Valves may be installed in both horizontal and vertical lines with upward flow or in any intermediate position.