

300 lb. WWP Bronze Hose Angle Valves

Fire Protection Valve • Rising Stem • Renewable Disc • Screw-in Bonnet

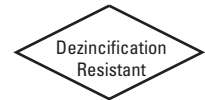

300 PSI/20.7 Bar Non-Shock Cold Water

CONFORMS TO MSS SP-80 •
UL LISTED • FM APPROVED

MATERIAL LIST

PART	SPECIFICATION
1. Handwheel Nut	Brass ASTM B 16
2. Handwheel	Malleable Iron
3. Stem	Silicon Bronze ASTM B 371 Alloy C69430
4. Packing Nut	Bronze ASTM B 62
5. Packing Gland	Bronze ASTM B 16 or ASTM B 62
6. Packing	Non Asbestos Aramid Fibers w/Graphite
7. Bonnet	Bronze ASTM B 62
8. Body	Bronze ASTM B 62
9. Disc Holder Nut	Bronze ASTM B 62
10. Drive Screw	18-8SS or Silicon Bronze ASTM B 411 Alloy C64700
11. Disc Holder	Bronze ASTM B 62
12. Hose Cap	Bronze ASTM B 62
13. Seat Disc	Rubber
14. Hose Cap Gasket	Rubber
15. Safety Chain	Brass
16. Seat Disc Nut	Bronze ASTM B 62
17. Cotter Key	Brass



T-331-HC

Threaded
w/Cap and Chain

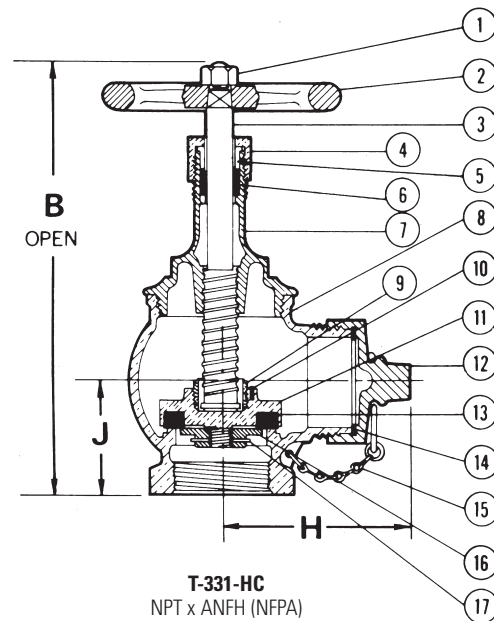

T-331-HC
NPT x ANFH (NFPA)
Hose 7.5 Threads
Per Inch

DIMENSIONS—WEIGHTS—QUANTITIES

Size	Dimensions						Weight		Box Qty.	Master Ctn. Qty.	
	B		H		J		Lbs.	Kg.			
In.	mm.	In.	mm.	In.	mm.	In.	mm.				
2½	65	10.50	267	5.13	130	3.06	78	15.61	7.08	1	4

