



SUCTION STRAINERS



Features – PVC

The Suction Strainer is a special Basket Strainer design that reduces pressure drop, a critical element in suction line applications. While same-size (inlet/outlet) units are available, the enlarged inlet on reducing sizes perform best in suction-line applications.

- Chemical & Corrosion Resistant PVC Construction
- Bolt-on Bonnet with Top Sight Glass, Standard
- Stainless Steel Strainer Basket with 3/16" Perforation, Standard
- Bottom-Drained Internal Strainer Basket for Direct Flushing
- 360° Adjustable Side Mounted Flush-Discharge Valve Assembly
- EPDM Seals Standard
- Pressure rated to 50 psi @ 73°F

Contact Spears® for additional Basket Mesh/Perforation, Elastomer seal options, or other custom requirements desired.

Sample Engineering Specification

All thermoplastic Suction Strainers shall be fabricated from PVC Type I Cell Classification 12454 material. All O-rings shall be EPDM. Strainer basket shall be type 316 stainless steel. Standard strainer perforations shall be 3/16" with a minimum open area ratio of 6:1. Basket shall have bottom-drained direct discharge with 360° adjustable side discharge assembly, including Ball Valve at terminal end. Unit shall have bolt-on bonnet with built-in sight glass. Suction strainer shall be pressure rated at 50 psi for water at 73°F, as manufactured by Spears® Manufacturing Company.

Suction Strainer Stainless Steel Baskets 3/16" Perforation

Size	Part Number
4	SSS4-040
6	SSS4-060
8	SSS4-080
10	SSS4-100
12	SSS4-120

Quick-View Suction Strainer Selection Chart

Valve Size	O-ring Material	Part Numbers	Pressure Rating
		Flanged	
4	EPDM	SS23BS4SG-040	50 psi Non-Shock Water @73°F
4 x 2	EPDM	SS23BS4SG-420	
4 x 2-1/2	EPDM	SS23BS4SG-421	
4 x 3	EPDM	SS23BS4SG-422	
6	EPDM	SS23BS4SG-060	
6 x 4	EPDM	SS23BS4SG-532	
8	EPDM	SS23BS4SG-080	
8 x 4	EPDM	SS23BS4SG-582	
8 x 6	EPDM	SS23BS4SG-585	
10	EPDM	SS23BS4SG-100	
10 x 6	EPDM	SS23BS4SG-626	
10 x 8	EPDM	SS23BS4SG-628	
12	EPDM	SS23BS4SG-120	
12 x 8	EPDM	SS23BS4SG-668	
12 x 10	EPDM	SS23BS4SG-670	

SUCTION STRAINERS

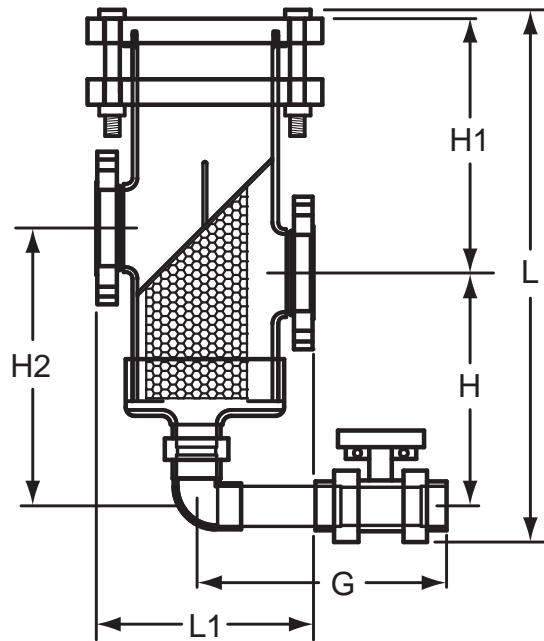

Dimensions

Size	G	H	H1	H2	L	L1
4	14-13/16	13-13/16	15-9/16	16-7/16	31-1/2	12-7/8
4 x 2	14-13/16	13-13/16	15-9/16	16-7/16	31-1/2	13-1/2
4 x 2-1/2	14-13/16	13-13/16	15-9/16	16-7/16	31-1/2	12-1/2
4 x 3	14-13/16	13-13/16	15-9/16	16-7/16	31-1/2	12-9/16
6	14-13/16	16-7/8	16-7/8	19-15/16	35-7/8	15-7/8
6 x 4	14-13/16	17-15/16	15-13/16	19-15/16	35-7/8	15-7/8
8	17-15/16	22-1/4	21-13/16	27-7/8	46-1/4	18
8 x 4	17-15/16	24-5/16	19-3/4	27-7/8	46-1/4	18
8 x 6	17-15/16	23-1/4	20-13/16	27-7/8	46-1/4	18-1/8
10	17-15/16	27-13/16	19-11/16	31-11/16	49-11/16	23-15/16
10 x 6	17-15/16	27-13/16	19-11/16	31-11/16	49-11/16	23
10 x 8	17-15/16	27-13/16	19-11/16	31-11/16	49-11/16	22-7/8
12	20-3/16	27-3/16	21-5/8	31-3/16	50-13/16	30
12 x 8	20-3/16	29-1/8	19-9/16	31-3/16	50-13/16	29
12 x 10	20-3/16	28-1/16	20-5/8	31-3/16	50-13/16	29-3/4

Temperature Pressure Rating

System Operating Temperature °F (°C)		100 (38)	110 (43)	120 (49)	130 (54)	140 (60)	150 (66)	160 (71)	170 (77)	180 (82)	190 (88)	200 (93)	210 (99)
Valve Pressure Rating psi (MPa)	4" - 12"	PVC	50 (.34)	45 (.31)	40 (.30)	35 (.24)	30 (.21)	-0-	-0-	-0-	-0-	-0-	-0-
		CPVC	50 (.34)	47 (.32)	45 (.31)	42 (.83)	40 (.30)	37 (.26)	35 (.24)	30 (.21)	25 (.17)	20 (.14)	15 (.10)