

175 lb. WWP Bronze Globe Valves

Fire Protection Valve • Screw-in Bonnet • Integral Seat • Renewable Disc

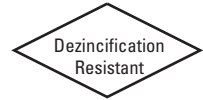

175 PSI/12.1 Bar Non-Shock Cold Water

CONFORMS TO MSS SP-80 • UL LISTED*

MATERIAL LIST

PART	SPECIFICATION
1. Handwheel Nut	300 Series Stainless Steel
2. Identification Plate	Aluminum
3. Handwheel	Aluminum Commercial Alloy 380
4. Stem	Silicon Bronze ASTM B 371 Alloy C69430
5. Packing Gland	Bronze ASTM B 62 or ASTM B 584 Alloy C84400 or ASTM B-282 or ASTM B 16
6. Packing Nut	Bronze ASTM B 62 or ASTM B 584 Alloy C84400 or ASTM B 16
7. Packing	Non Asbestos Aramid Fibers w/Graphite
8. Bonnet	Bronze ASTM B 62
9. Disc Holder Nut	Bronze ASTM B 140 Alloy C31400 or B 62
10. Disc Holder	Bronze ASTM B 62±/ ASTM B 9 Alloy C65100 w/SS Washer
11. Seat Disc	Nitrile (W) (1 1/4" - 2") TFE (Y) (2 1/2" - 3")
±12. Disc Nut	Bronze ASTM B 62/ASTM 89 Alloy C65100 w/SS Washer
13. Body	Bronze ASTM B 62

± 2 1/2" and 3" size only.

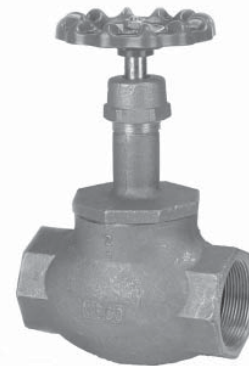

KT-211-W-UL

Threaded

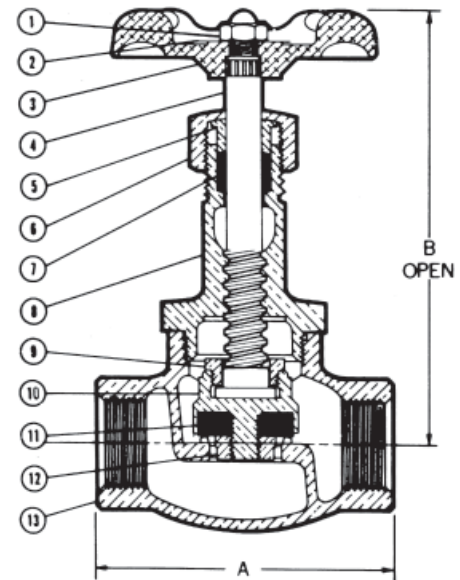

KT-211-W-UL
NPT x NPT

DIMENSIONS—WEIGHTS—QUANTITIES

Size	Dimensions				Weight		Box Qty.	Master Ctn. Qty.	
	In.	mm.	In.	mm.	Lbs.	Kg.			
1 1/4	32	4.31	110	6.13	156	3.55	1.61	2	10
1 1/2	40	4.69	119	7.19	183	5.50	2.49	2	10
2	50	5.38	143	7.94	202	8.25	3.75	2	6
**2 1/2	65	6.63	168	10.19	259	15.40	7.00	1	2
**3	80	7.75	197	11.19	284	22.44	10.20	1	2

*UL Listed for Trim and Drain use – sizes 1 1/4", 1 1/2", 2".

**Sizes 2 1/2" and 3" supplied as T-211-Y with TFE seat disc.

