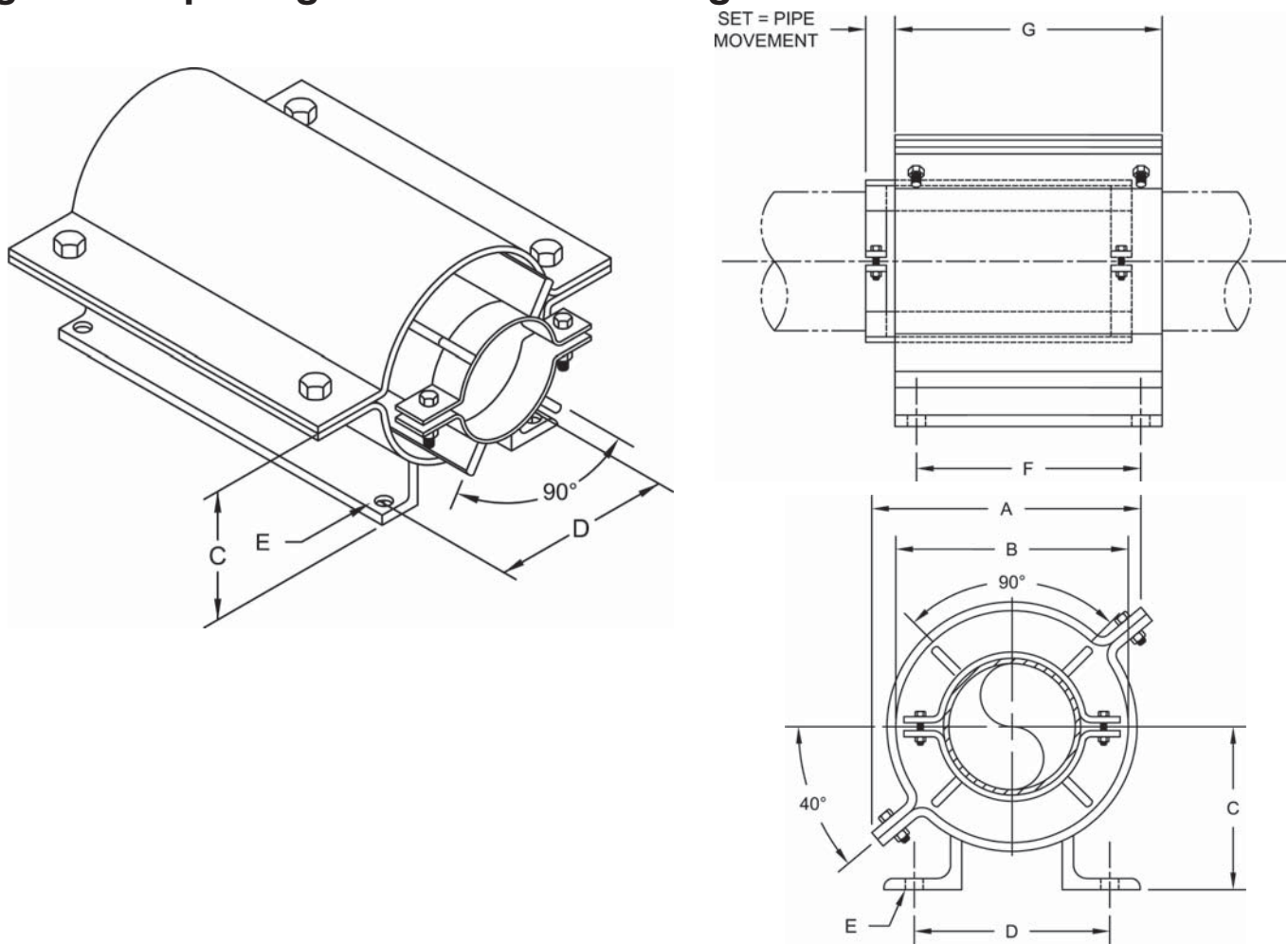

Fig. 420 - Pipe Alignment Guide — Long Traverse

Dimensions • Weights

Pipe Size	A	B	C	D	Hole Size E	F	G	Max. Insul. Thickness	Approx. Wt./100
3/4	8 ⁵ / ₁₆	4 ¹³ / ₁₆	4	5 ³ / ₄	5/8	5	12	1 ¹¹ / ₁₆	2430
1	8 ⁵ / ₁₆	4 ¹³ / ₁₆	4	5 ³ / ₄	5/8	5	12	1 ⁹ / ₁₆	2890
1 1/4	8 ⁵ / ₁₆	4 ¹³ / ₁₆	5	5 ³ / ₄	5/8	5	12	1 ³ / ₈	3261
1 1/2	9 ¹ / ₄	5 ³ / ₄	5	6	5/8	5	12	1 ¹³ / ₁₆	3257
2	11 ¹ / ₄	7 ⁹ / ₁₆	6	6 ⁵ / ₈	7/8	5	12	2 ³ / ₈	4017
2 1/2	11 ¹ / ₄	7 ⁹ / ₁₆	6	6 ⁵ / ₈	7/8	5	12	2 ¹ / ₈	4050
3	11 ¹ / ₄	7 ⁹ / ₁₆	6	6 ⁵ / ₈	7/8	5	12	1 ³ / ₄	4200
3 1/2	13 ¹ / ₄	9 ¹ / ₈	7 ¹ / ₂	8 ¹ / ₈	7/8	5	12	2 ⁵ / ₁₆	4483
4	13 ¹ / ₄	9 ¹ / ₈	7 ¹ / ₂	8 ¹ / ₈	7/8	5	12	2 ¹ / ₁₆	4491
5	15 ³ / ₄	11 ¹ / ₂	8 ¹ / ₂	9 ³ / ₈	7/8	5	12	2 ¹¹ / ₁₆	5771
6	15 ³ / ₄	11 ¹ / ₂	8 ¹ / ₂	9 ³ / ₈	7/8	5	12	2 ³ / ₁₆	7045
8	19 ⁵ / ₁₆	15	10	12 ⁷ / ₁₆	7/8	5	12	2 ¹⁵ / ₁₆	7495
10	21 ³ / ₄	17 ³ / ₈	11	13 ¹¹ / ₁₆	1 ¹ / ₈	5	12	2 ¹⁵ / ₁₆	9045
12	23 ⁷ / ₈	19 ³ / ₈	12	14 ¹ / ₄	1 ¹ / ₈	5	12	2 ¹⁵ / ₁₆	9901
14	27	20 ⁵ / ₈	13	15 ³ / ₄	1 ¹ / ₈	5	12	2 ¹⁵ / ₁₆	10614
16	29	22 ⁵ / ₈	14	17 ¹ / ₁₆	1 ¹ / ₈	5	12	2 ¹⁵ / ₁₆	12298
18	31 ¹ / ₄	25 ¹ / ₄	15	18 ⁵ / ₈	1 ¹ / ₈	5	12	3 ¹ / ₄	13393
20	33 ³ / ₈	27 ¹ / ₄	16	19 ³ / ₈	1 ¹ / ₈	5	12	3 ¹ / ₄	14062
24	36 ⁵ / ₈	31 ¹ / ₄	17	23 ¹¹ / ₁₆	1 ¹ / ₈	5	12	3 ¹ / ₄	15406