

## Fig. 110 - Standard U-Bolt with 4 Hex Nuts

**Size Range** — Size 1/2" thru 36" pipe

**Material** — Carbon Steel

**Function** — Recommended for support, anchor or guide of pipe.

**Approvals** — Conforms to Federal Specification WW-H-171E, Type 24 and Manufacturers Standardization Society SP-69 Type 24.

**Maximum Temperature** — 750°F

**Finish** — Plain

**Note** — Available in Electro-Galvanized and HDG finish or Stainless Steel materials.

**Order By** — Figure number, rod size and pipe size. U-bolt can be furnished with longer tangents "D" or with longer threads "E". Consult factory.

**Note** — When furnished in Hot-Dip Galvanized finish, oversize tapped hex nuts must be used.

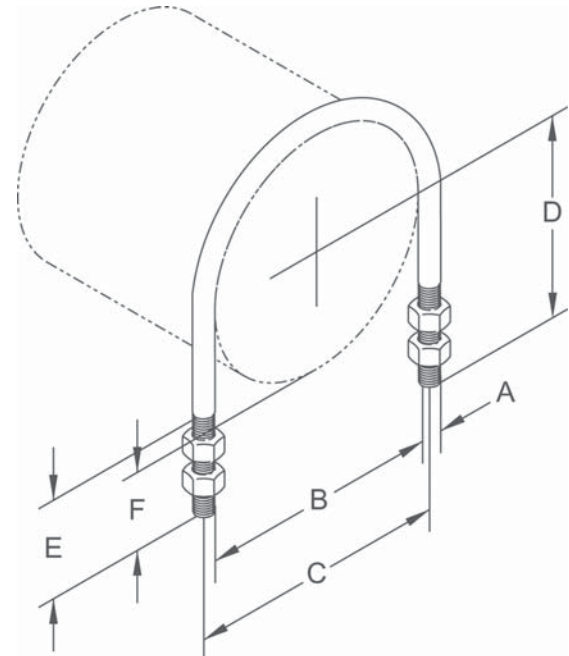

### Dimensions • Weights

Rod Size A	Pipe Size	B	C	D	E	F	Max. Rec. Load Lbs.		Approx. Wt./100
							for Service Temps. 650°F	750°F	
1/4	1/2	15/16	1 1/16	2 3/4	2 1/8	2 5/16	485	435	11
1/4	3/4	1 1/8	1 3/8	2 3/4	2 1/8	2 7/32	485	435	12
1/4	1	1 3/8	1 5/8	2 3/4	2 1/8	2 3/32	485	738	12
3/8	1 1/4	1 11/16	2 1/16	2 7/8	2 1/8	2 1/32	1220	1090	28
3/8	1 1/2	2	2 3/8	3	2 1/2	2 1/16	1200	1090	30
3/8	2	2 7/16	2 13/16	3 1/4	2 1/2	2 1/16	1220	1090	33
1/2	2 1/2	2 5/16	3 7/16	3 3/4	3	2 5/16	2260	2020	85
1/2	3	3 9/16	4 1/16	4	3	2 1/4	2260	2020	93
1/2	3 1/2	4 1/16	4 9/16	4 1/4	3	2 1/4	2260	2020	101
1/2	4	4 9/16	5 1/16	4 1/2	3	2 1/4	2260	2020	110
1/2	5	5 5/8	6 1/8	5	3	2 7/32	2260	2020	124
5/8	6	6 3/4	7 3/8	6 1/8	3 3/4	2 13/16	3620	3230	200
5/8	8	8 3/4	9 3/8	7 1/8	3 3/4	2 13/16	3620	3230	230
3/4	10	10 7/8	11 5/8	8 3/8	4	3	5420	4830	486
7/8	12	12 7/8	13 3/4	9 5/8	4 1/4	3 1/4	7540	6730	790
7/8	14	14 1/8	15	10 1/4	4 1/4	3 1/4	7540	6730	850
7/8	16	16 1/8	17	11 1/4	4 1/4	3 1/4	7540	6730	935
1	18	18 1/8	19 1/8	12 5/8	4 3/4	3 5/8	9920	8850	1360
1	20	20 1/8	21 1/8	13 5/8	4 3/4	3 5/8	9920	8850	1476
1	24	24 1/8	25 1/8	15 5/8	4 3/4	3 5/8	9920	8850	1698
1	30	30 1/8	31 1/8	18 5/8	4 3/4	3 5/8	9920	8850	2027
1	36	36 1/8	37 1/8	21 5/8	4 3/4	3 5/8	9920	8850	