

## Fig. 980 - Universal Swivel Sway Brace Attachment

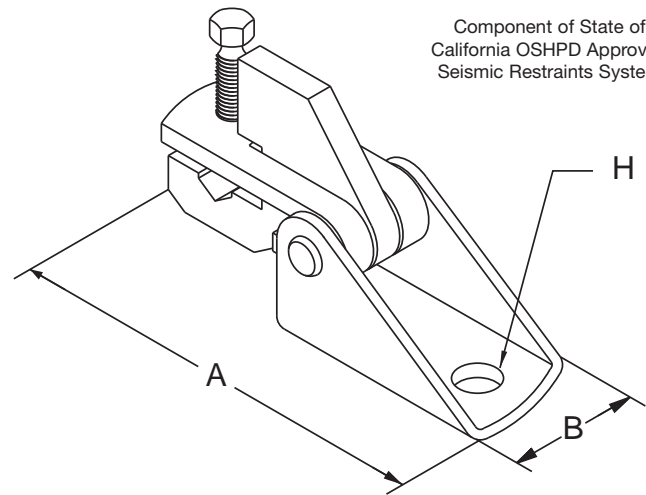

Component of State of California OSHPD Approved Seismic Restraints System



**Size Range** — One size fits bracing pipe 1" thru 2", TOLCO 12 gauge channel, and all structural steel up to 1/4" thick.

**Material** — Carbon Steel

**Function** — Multi-functional attachment to structure or braced pipe fitting.

**Features** — This product's design incorporates a **concentric** attachment opening which is critical to the performance of structural seismic connections. NFPA 13 (2002) Figure 9.3.5.9.1 indicates clearly that fastener table load values are based only on concentric loading. Mounts to any surface angle. Break off bolt head assures verification of proper installation.

**Installation** — The Fig.980 is the structural or transitional attachment component of a longitudinal or lateral sway brace assembly. It is intended to be combined with the "bracing pipe" and TOLCO "braced pipe" attachment, Fig. 1000, 1001, 2002, 4L, 4A or 4B to form a complete bracing assembly. NFPA 13 and/or OSHPD guidelines should be followed.

**To Install** — Place the Fig. 980 onto the "bracing pipe". Tighten the set bolt until set bolt head breaks off. Attachment can pivot for adjustment to proper brace angle.

**Approvals** — Underwriters Laboratories Listed in the USA (**UL**) and Canada (**cUL**). Approved by Factory Mutual Engineering (**FM**). Included in our Seismic Restraints Catalog approved by the State of California Office of Statewide Health Planning and Development (**OSHPD**). For additional load, spacing and placement information relating to OSHPD projects, please refer to the TOLCO Seismic Restraint Systems Guidelines.

**Note** — The Fig. 980 Swivel Attachment and the Fig. 1001, Fig. 1000, Fig. 2001 or Fig. 4A Pipe Clamp make up a sway brace system of **UL** Listed attachments and bracing materials which satisfies the requirements of Underwriters' Laboratories and the National Fire Protection Association (**NFPA**)

**Finish** — Plain

**Note** — Available in Electro-Galvanized finish.

**Order By** — Figure number and finish.

**PATENT #6,273,372**

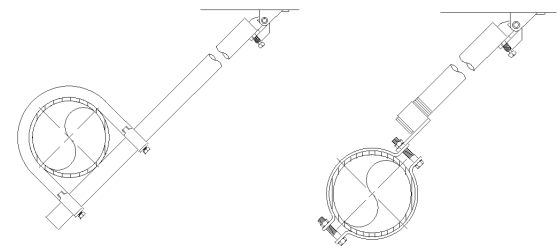

Lateral Brace

### Dimensions • Weights

A	B	H*	Max. Design Load Lbs. (cULus)	**Max. Design Load Lbs. (FM)	Approx. Wt./100
5¼	1⅞	17/32	2765	2800	132

\* Available with hole sizes to accommodate up to 3/4" fastener. Consult factory.

\*\* Load shown is allowable with brace installed, between 30° - 90°. No reduction of load based on brace angle is required.

TOLCO<sup>®</sup> brand bracing components are designed to be compatible **ONLY** with other TOLCO<sup>®</sup> brand bracing components, resulting in a Listed seismic bracing assembly. **DISCLAIMER** — NIBCO does **NOT** warrant against the failure of TOLCO<sup>®</sup> brand bracing components, in the instance that such TOLCO<sup>®</sup> brand bracing components are used in combination with products, parts or systems which are not manufactured or sold under the TOLCO<sup>®</sup> brand. NIBCO shall **NOT** be liable under any circumstance for any direct or indirect, incidental or consequential damages of any kind, including but not limited to loss of business or profit, where non-TOLCO brand bracing components have been, or are used.