

175 lb. WWP Iron Body Gate Valves

Fire Protection Valve • Bolted Bonnet • Outside Screw and Yoke • Solid Wedge •
Pre-Grooved Stem for Supervisory Switch Mounting

175 PSI/12.1 Bar Non-Shock Cold Water

CONFORMS TO MSS SP-70 •
UL/ULC LISTED • FM APPROVED •
APPROVED BY THE NEW YORK CITY B.S.A. 143-69-SA

MATERIAL LIST

PART	SPECIFICATION
1. Stem	Brass ASTM B 16 Alloy C36000
2. Handwheel Nut	Cast Bronze B 584 Alloy C84400
3. Identification Plate	Aluminum
4. Yoke Bushing	Cast Bronze B 584 Alloy C84400
5. Handwheel	Cast Iron ASTM A 126 Class B
6. Bonnet Cap Nut	Steel ASTM A 307
7. Bonnet Cap	Ductile Iron ASTM A 536
8. Bonnet	Cast Iron ASTM A 126 Class B
9. Bonnet Cap Bolt	Steel ASTM A 307
10. Gland Follower Nut	Brass ASTM B 36
11. Gland Follower	Ductile Iron ASTM A 536
12. Packing Gland	Zinc Plated Powdered Iron ASTM B 310 or Cast Brass ASTM Alloy C36000
13. Packing	Non Asbestos
14. Gland Follower Bolt	Steel ASTM A 307
15. Backseat Bushing	Cast Bronze B 584 Alloy C84400
16. Body Nut	Steel ASTM A 307
17. Body Bolt	Steel ASTM A 307
18. Wedge Pin	Silicon Bronze B 140 Alloy C31600
19. Body	Cast Iron ASTM A 126 Class B
20. Seat Ring	Cast Bronze B 584 Alloy C84400
21. Wedge Face Rings	Cast Bronze B 584 Alloy C84400
22. Wedge	Cast Bronze B 584 Alloy C84400
23. Body Gasket	Non Asbestos
24. Stem Collar	Brass ASTM B 16 Alloy C36000

¹Sizes up to 8" inclusive made with yoke integral with bonnet.
10" and 12" sizes made with separate yoke bolted to bonnet.
²Sizes 2½" thru 6" are all bronze wedges.
Sizes 8" thru 12" made with cast iron wedge with bronze wedge face rings
TS: pre-grooved stem for supervisory switch mounting.

DIMENSIONS—WEIGHTS—QUANTITIES

Size	Dimensions										Weight		
	A		B		C		D		E		Lbs.	Kg.	
In. mm.	In.	mm.	In.	mm.	In.	mm.	In.	mm.	In.	mm.			
2½	65	7.50	191	16.88	429	8.00	203	7.00	178	.69	17	55	25
3	80	8.00	203	19.75	502	8.00	203	7.50	191	.75	19	66	30
4	100	9.00	229	24.00	610	10.00	254	9.00	229	.94	24	107	49
5	125	10.00	254	27.50	699	10.00	254	10.00	254	.94	24	145	66
6	150	10.50	267	31.50	800	12.00	305	11.00	279	1.00	25	179	81
8	200	11.50	292	40.75	1035	14.00	356	13.50	343	1.13	29	308	140
10	250	13.00	330	48.50	1232	16.00	406	16.00	406	1.19	30	481	219
12	300	14.00	356	57.00	1448	18.00	457	19.00	483	1.25	32	706	321

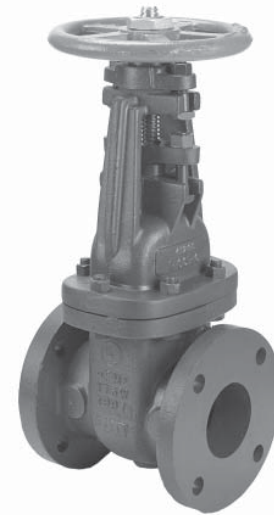

F-607-OTS
Flanged

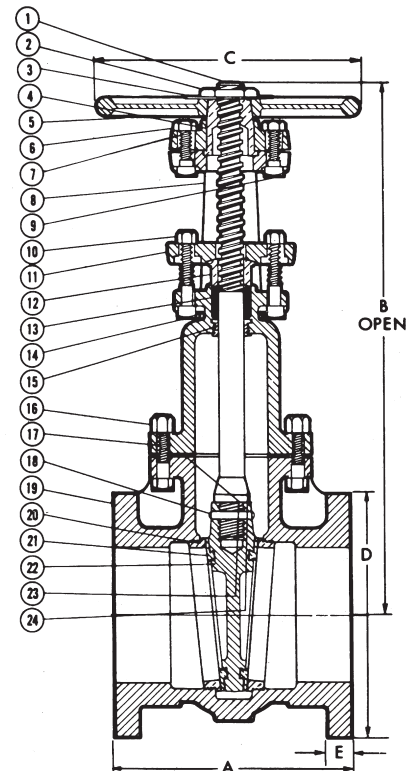

F-607-OTS
Flg x Flg

FREEZING WEATHER PRECAUTION: Subsequent to testing a piping system, gate valve should be in an open position to allow complete drainage.

Note: Available to ISO Flange dimensions.
Specify F-607-01. See page 50.

