

## Fig. 101L - Linked Welded Eye Rod

**Size Range** — 3/8" thru 1½" rod

**Material** — Carbon Steel

**Function** — Designed for use in a hanger assembly where universal movement is necessary. The welded eye rods allow for heavier loads.

**Finish** — Plain

**Note** — Available in Electro-Galvanized and HDG finish or Stainless Steel materials.

**Order By** — Figure number, rod size, dimension A, B, and C.

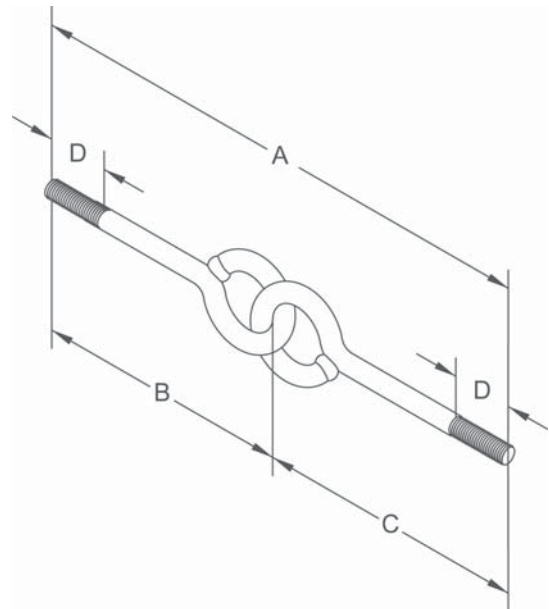

Dimensions		
Rod Size	D*	Max. Rec. Load Lbs. for Service Temps. 650°F
3/8	2½	610
1/2	2½	1130
5/8	2½	1810
3/4	3	2710
7/8	3½	3770
1	4	4960
1¼	5	8000
1½	6	11630

\* Where length is shorter than 10" consult factory for thread length.

## Fig. 102L - Linked Eye Rod Not Welded

**Size Range** — 3/8" thru 1½" rod

**Material** — Carbon Steel

**Function** — Designed for use in a hanger assembly where universal movement is necessary.

**Finish** — Plain

**Note** — Available in Electro-Galvanized and HDG finish or Stainless Steel materials.

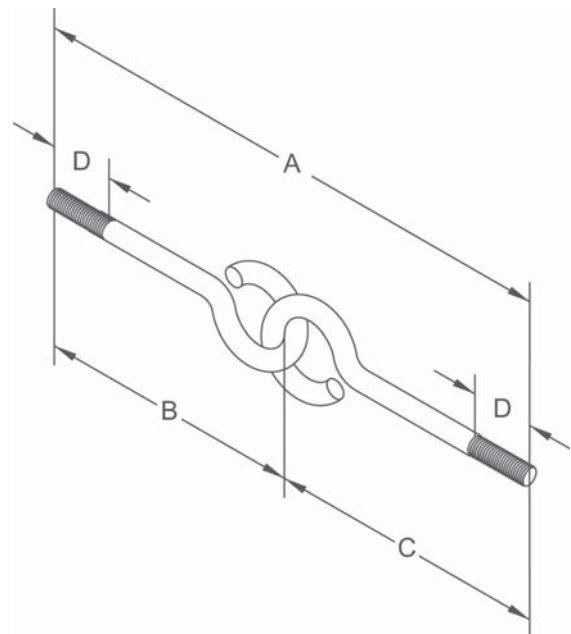

Dimensions		
Rod Size	D*	Max. Rec. Load Lbs. for Service Temps. 650°F
3/8	2½	240
1/2	2½	440
5/8	2½	705
3/4	3	1050
7/8	3½	1470
1	4	1940
1¼	5	3120
1½	6	4650

\* Where length is shorter than 10" consult factory for thread length.