

# 175 lb. WWP Bronze Angle Valves

Fire Protection Valve • Screw-in Bonnet • Integral Seat • Renewable Disc

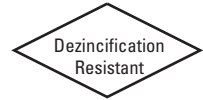

175 PSI/12.1 Bar Non-Shock Cold Water

CONFORMS TO MSS SP-80 • UL/ULC LISTED\*

## MATERIAL LIST

PART	SPECIFICATION
1. Handwheel Nut	300 Series Stainless Steel
2. Identification Plate	Aluminum
3. Handwheel	Aluminum Commercial Alloy C38000
4. Stem	Silicon Bronze ASTM B 371 Alloy C69430
5. Packing Gland	Bronze ASTM B 62/ ASTM B 16†/ ASTM B 584 Alloy C84400
6. Packing Nut	Bronze ASTM B 62/ ASTM B 584 Alloy C84400/ASTM B 16
7. Packing	Non Asbestos Aramid Fibers w/Graphite
8. Bonnet	Bronze ASTM B 62 Alloy C83600
9. Disc Holder Nut	Bronze ASTM B 62 Alloy C83600
10. Disc Holder	Bronze ASTM B 62 Alloy C83600
11. Seat Disc	Nitrile (W) (1 1/4" - 2") TFE (Y) (2 1/2" - 3")
12. Seat Disc Nut	Bronze ASTM B 62†/ ASTM B 96 Alloy C65100 w/SS Washer
13. Body	Bronze ASTM B 62/B 584 Alloy C83600

‡ 2 1/2" and 3" size only.  
† Not on 2"



**T-301-W**  
Threaded

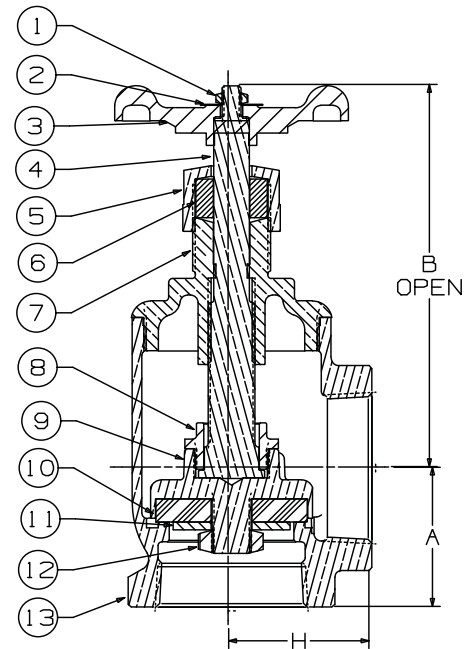

**T-301-W**  
NPT x NPT

## DIMENSIONS—WEIGHTS—QUANTITIES

Size	Dimensions						Weight		Box Qty.	Master Ctn. Qty.
	A		B		H		Lbs.	Kg.		
In. mm.	In.	mm.	In.	mm.	In.	mm.				
1 1/4 32	2.19	56	6.13	156	2.19	56	3.71	1.69	1	10
1 1/2 40	2.38	60	7.19	183	2.38	60	5.54	2.52	1	10
2 50	2.25	57	7.25	184	2.25	57	6.72	3.05	1	10
**2 1/2 65	3.19	81	10.56	268	3.19	81	16.13	7.33	1	2
**3 80	3.88	86	11.13	283	3.88	86	21.72	9.87	1	2

\* UL/ULC Listed for sizes for trim and drain use 1 1/4", 1 1/2", 2".

\*\* Sizes 2 1/2" and 3" supplied as T-311-Y with TFE seat disc.

