

175 lb. WWP Bronze Gate Valves

Fire Protection Valve • Block Pattern • Screw-over Bonnet •
Outside Screw and Yoke • Solid Wedge

**175 PSI/12.1 Bar Non-Shock Cold Water
(400 PSI Non-Shock CWP General Service)**

UL/ULC LISTED • FM APPROVED •
APPROVED BY THE NEW YORK CITY B.S.A. 143-69-SA

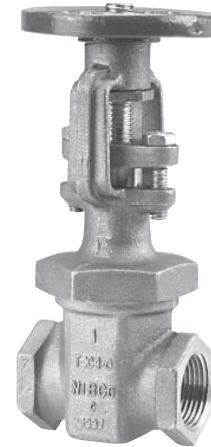

T-104-0
Threaded

MATERIAL LIST

PART	SPECIFICATION
1. Set Screw	Steel ASTM A 307
2. Handwheel	Malleable Iron
3. Yoke Bushing	Brass ASTM B 16
4. Gland Bolts	Steel ASTM A 307 Zinc Plated
5. Packing Gland	Bronze ASTM B 62
6. Packing	Non Asbestos Aramid Fibers w/Graphite
7. Bonnet	Bronze ASTM B 62
8. Stem	Silicon Bronze ASTM B 371 Alloy C69430
9. Stem Collar	Silicon Bronze ASTM B 371 Alloy C69430
10. Wedge Pin	Bronze ASTM B 140 Alloy C31400
11. Wedge	Bronze ASTM B 62
12. Body	Bronze ASTM B 62

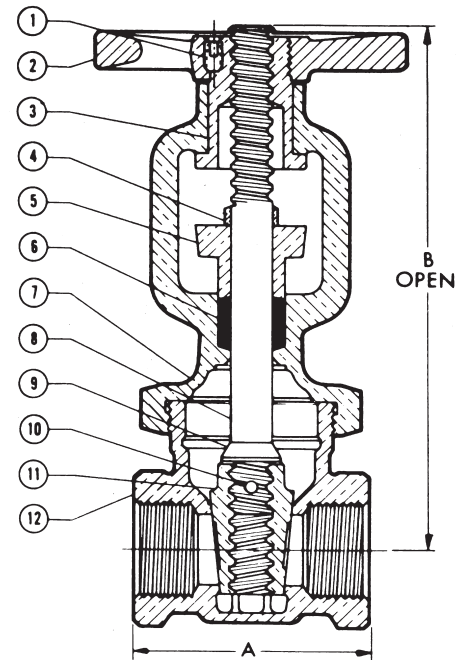

T-104-0
NPT x NPT

DIMENSIONS—WEIGHTS—QUANTITIES

Size	Dimensions				Diameter		Handwheel		Box Qty.	Master Ctn. Qty.	
	In.	mm.	In.	mm.	In.	mm.	Lbs.	Kg.			
1/2	15	2.19	59	5.88	149	3.25	88	2.28	1.04	1	20
3/4	20	2.44	62	6.44	164	3.25	88	2.83	1.29	1	20
1	25	2.88	73	7.44	189	3.25	88	3.67	1.67	1	10
1 1/4	32	3.13	79	8.69	221	4.00	100	5.83	2.65	1	10
1 1/2	40	3.38	84	9.38	238	4.00	100	6.84	3.11	1	10
2	50	3.44	87	10.59	269	3.50	89	9.74	4.44	1	6

