

B8 SERIES

FULL PORT

1/4" - 3"
PROCESS QUALITY
BALL VALVES

Size

1/4" - 3"

End Connections:

NPT
Butt Weld
Socket Weld

Valve Materials:

316 Stainless Steel
Carbon Steel, A-20, Hast-C

Ball and Stem Materials:

316 Stainless Steel
Alloy 20
Monel
Hastelloy C

Service Applications:

Hydraulics Chemical
Steam Oil/Gas
Oxygen Food Processing
Vacuum Dry/Liquid Chlorine
Thermal Fluids

Seat Materials

TFM Standard
Reinforced Teflon
SupraLon (Steam & Thermal Fluids)
Delrin
Teflon
Tempre K (PEEK)
UHMWPE

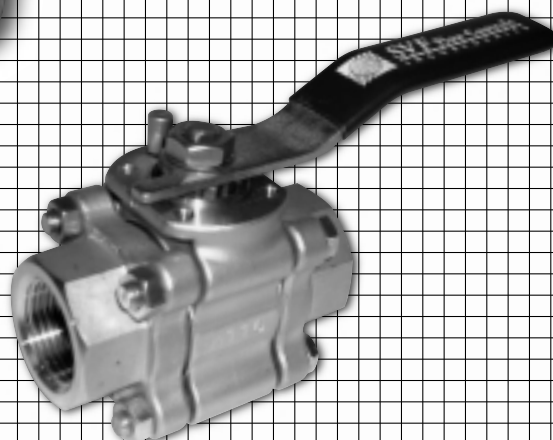
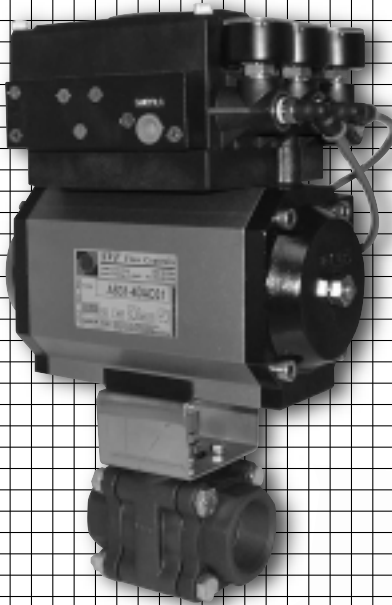

FEATURING FIELD WELDABILITY
WITHOUT DISASSEMBLY

B8 VALVE COMPONENTS

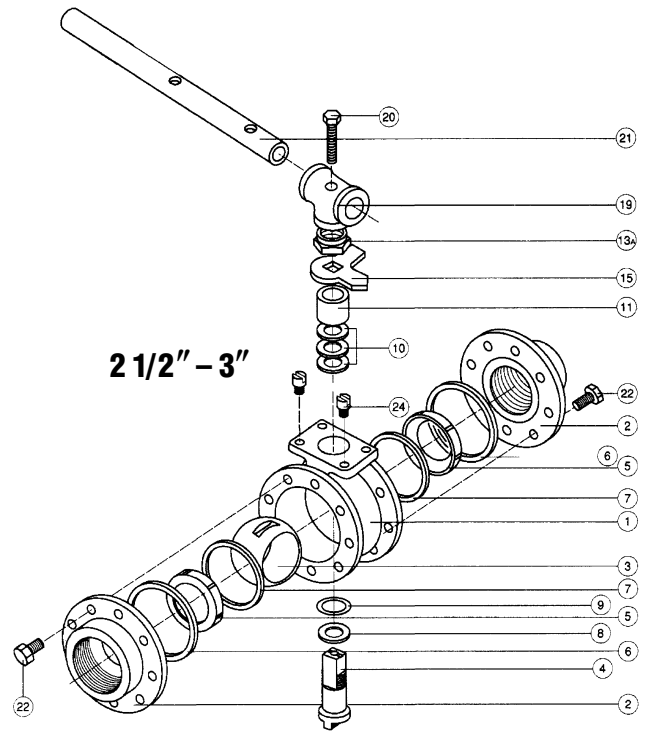
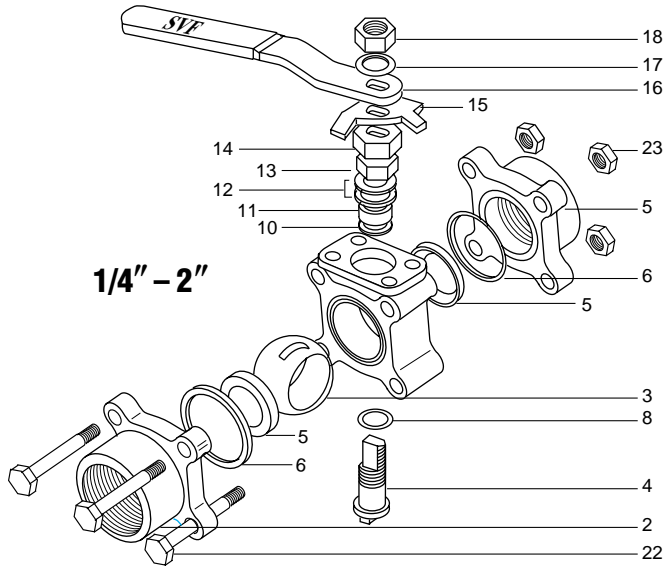

Item #	Description	Material
1	Body	Carbon Steel 316 Stainless
2	Body Connector	Carbon Steel 316L Stainless
3	Ball	316 Stainless Alloy 20 Monel Hastelloy C
4	Stem	316 Stainless Alloy 20 Monel Hastelloy C
5	Valve Seat	TFM (Std.), SupraLon Delrin, UHMWPE, PEEK
6	Body Connector Seal	TFE, Buna "N", SupraLon Graphoil UHMWPE
7	Retainer Ring 2 1/2"-3"	316 Stainless Carbon Steel
8	Stem Thrust Ring	NRG/SupraLon
9	Stem Location Ring 2 1/2"-3"	Stainless Steel
10	Stem Packing	NRG/SupraLon
11	Gland Packing	Stainless Steel

Item #	Description	Material
12	Belleville Washers	Stainless Steel
13	Packing Nut 1/4"-2"	Stainless Steel
13A	Packing Nut 2 1/2"-3"	Cad. Plate C. St. - Stainless Steel
14	Lock Tab	Stainless Steel
15	Handle Stop	Stainless Steel - Carbon Steel
16	Handle 1/4"-2 1/2"	Stainless Steel - Carbon Steel
17	Lock Washer	Stainless Steel
18	Handle Nut 1/4"-2"	Stainless Steel - Carbon Steel
19	Wrench Hub 2 1/2"-3"	Cad. Plate C. St. - Stainless Steel
20	Hub Bolt 2 1/2"-3"	Stainless Steel Cad. Plate C. St.
21	Wrench 2 1/2"-3"	Cad. Plate C. St.
22	Body Connector Bolt	Stainless Steel - Carbon Steel
23	Body Connector Nut	Stainless Steel - Carbon Steel
24	Stop Pin	Stainless Steel

PERFORMANCE DATA

VALVE SIZE	APPROX. FLOW COEFF.	EQUIV. LENGTH OF SCHED. 40 PIPE feet
1/2"	12	5.5
3/4"	32	3.0
1"	57	3.1
1-1/4"	80	3.9
1-1/2"	104	7.5
2"	240	5.0
2-1/2"	320	7.0
3"	580	9.5

Due to continuous development of our product range, we reserve the right to change the dimensions contained in this leaflet as required.

PRESSURE-TEMPERATURE DATA

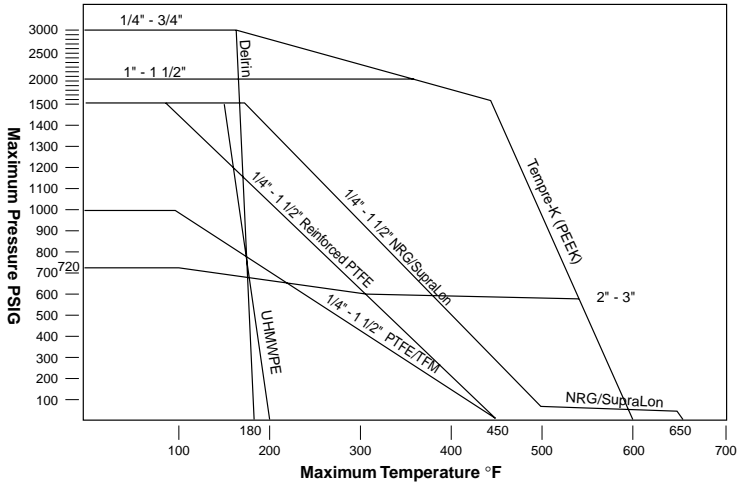

B8 DIMENSIONS & WEIGHT 1/4" - 2"

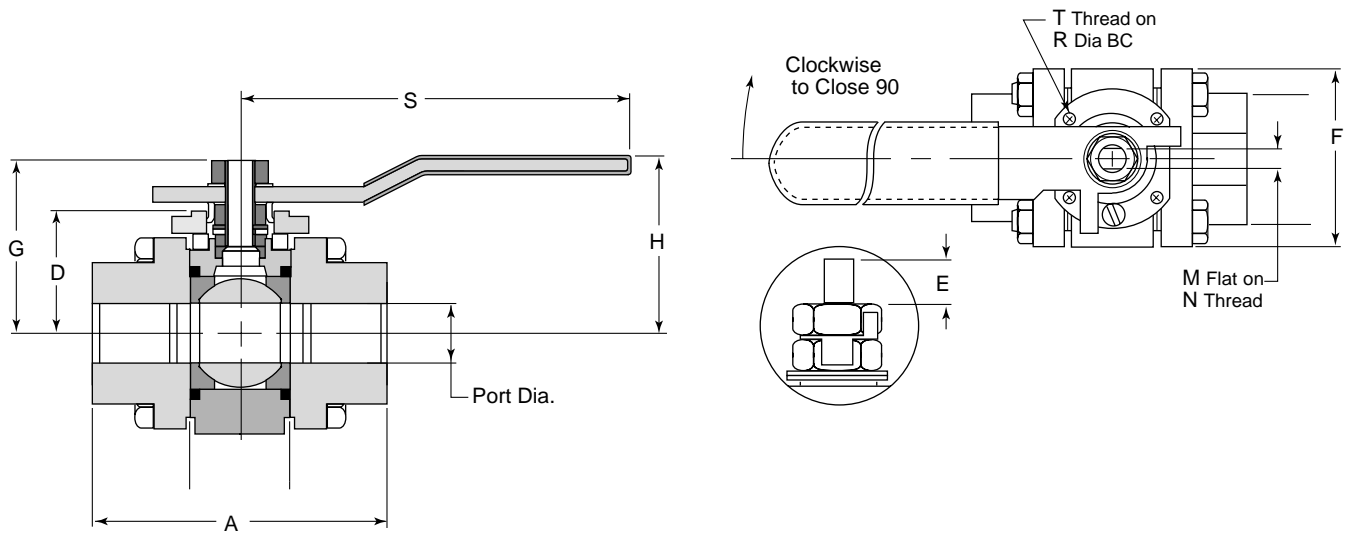

Size	A	D	E	F	G	H	M	N	R PCD	S	T	PORT	WEIGHT lbs.
1/4"	2.60	1.080	0.24	1.81	1.50	1.81	0.218	0.368	1.417	4.49	M5	0.25	1.7
3/8"	2.60	1.080	0.24	1.81	1.50	1.81	0.218	0.368	1.417	4.49	M5	0.375	1.7
1/2"	2.80	1.24	0.24	2.05	1.59	1.87	0.218	0.368	1.417	4.49	M5	0.50	2.00
3/4"	3.70	1.504	0.29	2.45	2.19	2.40	0.298	0.432	1.653	5.75	M5	0.75	3.7
1"	4.25	1.465	0.32	2.68	2.38	2.60	0.298	0.432	1.653	5.75	M5	1.00	5.00
1-1/4"	4.57	1.713	0.29	3.15	2.87	3.15	0.343	0.554	1.969	7.00	M6	1.25	7.3
1-1/2"	5.04	1.870	0.31	3.55	3.07	3.31	0.343	0.554	1.969	7.00	M6	1.50	10.3
2"	5.96	2.125	0.33	4.25	3.37	3.37	0.343	0.554	1.969	11	M6	2.00	18.00

OPERATING TORQUE (lbf.in.) FOR B8 VALVES WITH TFM SEATS

Seat: TFM

Line Pressure (psig)

Size	100	200	300	400	500	600	700	800	900	1000
1/4"	30	30	30	30	30	30	30	30	30	30
3/8"	30	30	30	30	30	30	30	30	30	30
1/2"	30	30	30	30	30	30	30	30	30	30
3/4"	50	50	50	60	60	60	60	60	60	60
1"	100	100	100	100	100	100	100	100	100	100
1-1/4"	150	150	150	150	150	200	200	200	200	200
1-1/2"	250	250	250	250	250	250	250	250	250	250
2"	275	325	375	400	500	500	500			
2-1/2"	400	500	600	700	800	800	800			
3"	800	900	1000	1000	1250	1250	1250			

B8 DIMENSIONS & WEIGHT 2 1/2"– 3"

NOTE:
WRENCH TUBE SHOWN FULLY EXTENDED
BUT CAN BE FITTED IN MID-POSITION AS
TEE-WRENCH

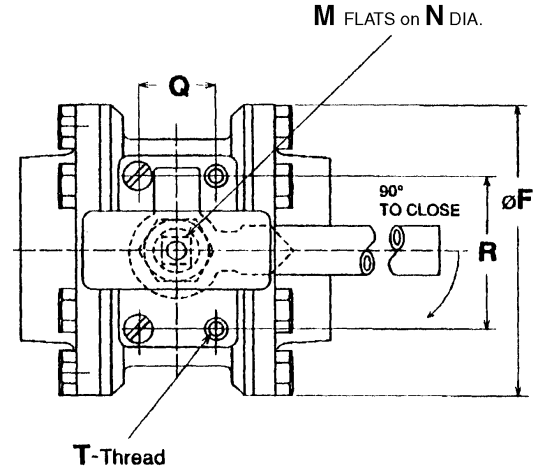
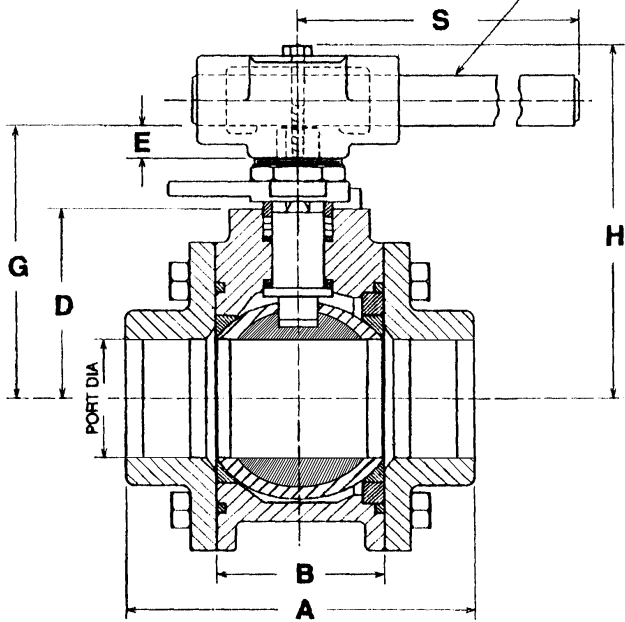

Valve Size	Port	Approx. Weight lbs.
2 1/2	2.50	30.0
3	3.00	50.3

Size	A	B	D	E	F	G	H	M	N	Q	R	S	T
2 1/2"	6.65	3.28	3.87	0.66	6.44	5.72	7.30	0.745	1"-14 UNS	1.75	3.37	13.8	M10
3"	8.41	4.28	4.49	0.66	7.97	6.34	7.92	0.745	1"-14 UNS	1.75	3.37	22.0	M10

B-SERIES VARIATIONS

The B-Series valve is available in a variety of body styles and pipe-end configurations. These include chlorine valves and steam/thermal fluid valves. For a complete listing of SVF products, contact your local SVF distributor.

GENERAL NOTES

1. Weld in-line valves - B8 ball valves feature an encapsulated body seal. This design permits in-line welding without the need for field disassembly. (There are some limitations based on seat material. Contact SVF.)
2. TFM supplied as standard. Other materials are supplied to order.
3. Stainless Steel Valves are fitted with stainless steel body bolts, nuts, gland nuts and handles as standard.
4. Delrin and UHMWPE are unsuitable for steam service.
5. Delrin is not suitable for oxygen service. Not available 2"-3".
6. PLEASE NOTE: All dimensions are taken to 2 decimal places. If more accurate measurements are required, please contact SVF. For mounting bracket dimensions contact SVF.

FEATURES & BENEFITS

FEATURES	BENEFITS
1. 3-Piece construction.	Enables valve to meet any pipe end requirements. Facilitates installation, eliminates unions. Maintains alignment while servicing. Provides easy internal access. Easily automated.
2. Lightweight & compact.	Saves weight, cost and envelope space.
3. Sealing package.	Downstream sealing guarantees tight shut-off, low torque.
4. Bottom entry stem.	Reduces chance of blowout, enhances safety.
5. Adjustable, self-compensating stem design.	Automatically adjusts for wear, temperature and pressure fluctuation.
6. Broad material selection.	Makes valve suitable to a wide range of applications.
7. Wide variety of options.	To customize to specific applications requirements.
8. Stainless pipe ends are 316 L grade.	Reduces intergranular corrosion in welding.
9. Stainless steel externals on 1/4" - 2" stainless valves.	Provides total corrosive protection, offers custom additional coast savings.
10. ISO mounting pad.	Allows for actuator mounting without interrupting integrity of valve. Interchangeability of valves.

The **B8 Series** incorporates all the above features & benefits and in addition offers:

11. Encapsulated body seal.	B8 weld end valves have an encapsulated body seal which does not require the valve to be disassembled prior to being welded in line.
-----------------------------	--

BOTTOM ENTRY STEM

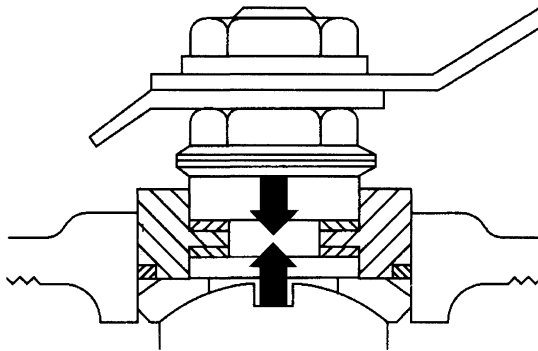

The B8 offers a stem that is inserted from inside the body cavity, is adjustable and self containing.

Belleville washers compensate for expansion and contraction as well as wear. Trapped cavity pressure is relieved through a hole in the ball (open position) to prevent stem damage.

FLOATING BALL, DOWNSTREAM SEALING DESIGN

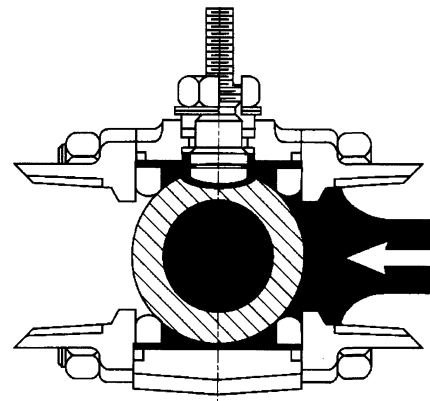

Valve shown in closed position, full pressure.

The B8 offers downstream sealing and bi-directional flow. This is obtained by allowing pressure to bypass the upstream seat through relief slots, and the ball being floated downstream to affect bubble - tight shut off.

This results in lower friction, less operating torque and longer valve life.

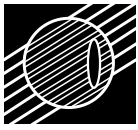

AUTOMATED PRODUCTS

Three piece construction of the B8 Series readily lends itself to automation with either factory assembly or infield retrofit. All SVF actuators may be removed for inspection or repair without affecting valve integrity.



Pneumatic Actuators

- Double Acting
- Spring Return
- Solenoids
- Limit Switches
- Positioners 3-15 PSI
- Positioners 4-20 MA

Electric Actuators

- 120 VAC
- 12/24 VDC
- NEMA 4/7
- Positioners 4-20 MA
- Reversing

Manual Valves

- Oval Handle
- Spring - Return
- Stem Extensions
- Fusible Link
- Locking Device
- Gear Operators

HOW TO ORDER

1" B8 6 6 6 6 A T SE

SIZE	STYLE	BODY & END MATERIAL	BALL & STEM MATERIAL	SEAT	SEAL	ENDS
1/4"	B8 (ISO Design 1/4"-2 1/2")	4 - Carbon Steel	3 - Monel	A - TFM	B - Buna "N"	SE - Screwed (NPT)
3/8"		6 - 316 Stainless	6 - 316 Stainless	R - Reinforced Teflon®	E - Ethylene Propylene Rubber (EPR, EPDM)	BW - Butt Weld
1/2"		Steel	Steel		V - Viton®	SW - Socket Weld
3/4"			8 - Alloy 20		T - Virgin Teflon®	
1"			9 - Hastelloy C		U - UHMWPE	
1-1/4"					D - Delrin*	
1-1/2"					S - SupraLon	
2"				U - UHMWPE		Option <input type="checkbox"/>
2-1/2"				K - Tempre K (PEEK)	G - Graphoil	H - Upstream Vent Hole
3"					S - SupraLon	

*Not available 2" - 3". Teflon® and Viton® are Registered Trademark of EI Dupont.