

250 lb. WWP Iron Body Gate Valves

Fire Protection Valve • Bolted Bonnet • Indicator Post Pattern • Non-Rising Stem •
Resilient Wedge • Epoxy Coated Interior/Exterior

250 PSI/17.2 Bar Non-Shock Cold Working Pressure
(160° F/71° C max. operating temperature)

UL/ULC LISTED • FM APPROVED • AWWA C509 & 515



FM609-RW
Flanged x Mechanical Joint

MATERIAL LIST

PART	SPECIFICATION
1. Valve Body	Ductile Iron ASTM A 536
2. Resilient Wedge	Ductile Iron ASTM A 536/EPDM ASTM D 2000
3. Wedge Nut	Bronze ASTM B 584 UNS C83600
4. Stem	Bronze ASTM B 150 UNS C61400
5. Bonnet Gasket	EPDM ASTM D 2000
6. Bonnet Screw	18-8 Stainless Steel ASTM 193
7. Bonnet	Ductile Iron ASTM A 536
8. Stem Primary O-Ring	EPDM ASTM D 2000
9. Stem Thrust Washer-Lower	Bronze ASTM B 584 UNS C83600
10. Stem Thrust Washer-Upper	Stainless Steel A 276 UNS S41000
11. Gland Seal O-Ring	EPDM ASTM D 2000
12. Stem Seal Bushing	Bronze ASTM B 584 UNS C83600
13. Stem Secondary O-Ring	EPDM ASTM D 2000
14. Gland Flange	Ductile Iron ASTM A 536
15. Stem Ring Wiper	EPDM ASTM D 2000
16. Square Operating Nut	Cast Iron ASTM A 126-B
17. Operating Nut Washer	Carbon Steel Zinc Plated
18. Operating Nut Screw	Alloy Steel ASTM A 574M Zinc Plated
19. Gland Flange Screw	Alloy Steel ASTM A 574M Zinc Plated
20. Indicator Flange Screw	Alloy Steel ASTM A 574M Zinc Plated
21. Indicator Post Flange	Ductile Iron ASTM A 536
22. UL/FM Label (not shown)	Aluminum

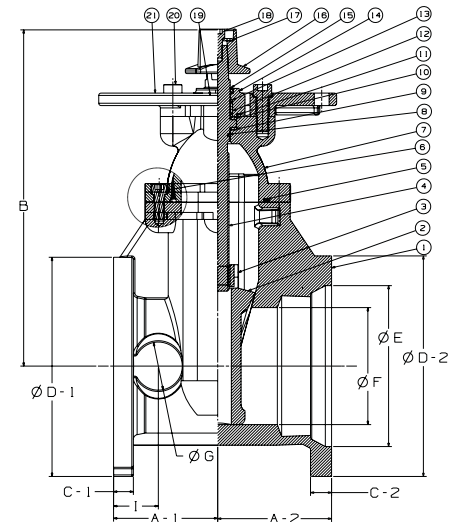

FM609-RW
Flg x MJ

DIMENSIONS—WEIGHTS—QUANTITIES

Size	A-1		A-2		B		C-1		C-2		D-1		D-2		E		F		
	In.	mm.	In.	mm.	In.	mm.	In.	mm.	In.	mm.	In.	mm.	In.	mm.	In.	mm.	In.	mm.	
3	80	4.00	102	4.00	102	12.60	321	0.75	19	0.09	24	7.50	191	7.70	195	4.90	126	3.10	80
4	100	4.50	115	5.00	127	13.50	344	0.94	24	1.00	26	9.00	229	9.10	232	6.00	153	3.90	100
6	150	5.30	134	5.70	146	17.40	441	1.00	25	1.06	27	11.00	279	11.10	283	8.10	206	5.90	150
8	200	5.70	146	5.70	146	20.80	529	1.13	29	1.12	28	13.50	343	13.40	340	10.30	261	7.90	200
10	250	6.50	165	6.50	165	24.00	614	1.19	30	1.18	30	16.00	406	15.60	397	12.30	313	9.80	250
12	300	7.00	178	7.00	179	27.60	700	1.25	32	1.25	32	19.00	486	17.90	454	14.40	367	11.80	300

Size	G		H		I		Flanged B.C.		MJ B.C.		No. Holes Flanged	No. Holes M-Joint	Turns To Open	Weight Lbs. Kg.	
	In.	mm.	In.	mm.	In.	mm.	In.	mm.	In.	mm.					
3	80	2.10	54	10.20	260	1.73	44	6.00	152	6.19	157	4	4	10.8	65 30
4	100	2.10	54	10.20	260	2.13	54	7.50	191	7.50	191	8	4	13.0	92 42
6	150	2.50	64	14.80	375	2.24	57	9.50	241	9.50	241	8	6	15.7	134 61
8	200	2.80	70	14.80	375	2.48	63	11.75	296	11.75	298	8	6	17.3	192 87
10	250	2.80	70	15.70	400	2.56	65	14.25	362	14.00	356	12	8	21.4	288 131
12	300	3.40	86	19.70	500	2.91	74	17.01	432	16.25	413	12	8	25.3	410 176



FREEZING WEATHER PRECAUTION: Subsequent to testing a piping system, valves should be left in an open position to allow complete drainage.