

Fig. 306 - Turnbuckle with Swivel Short Pattern

Size Range — 3/8" thru 3/4" rod

Material — Malleable Iron

Function — To provide an adjustable threaded connection for hanger rods when used with Fig. 303 Split Ring Hanger.

Approvals — Conforms to Federal Specification WW-H-171E, Type 15 and Manufacturers Standardization Society SP-69, Type 15.

Finish — Plain

Note — Available in Electro-Galvanized finish

Order By — Figure number, rod size and finish

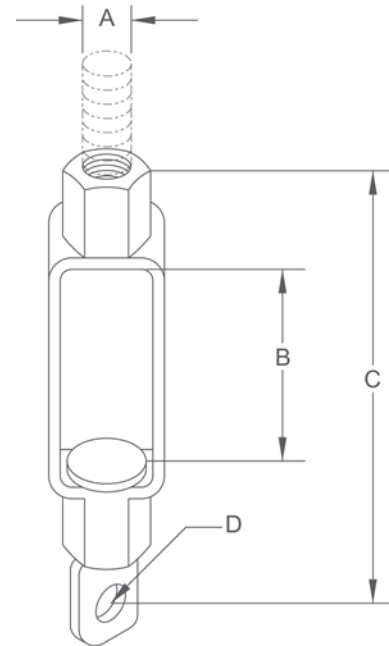

Dimensions • Weights

Pipe Size	Rod Size A	B	C	D	Max. Rec. Load Lbs.	Approx. Wt./100
1/2 - 2	3/8	2	3 ³ / ₄	7/16	610	28
2 ¹ / ₂ - 3 ¹ / ₂	1/2	2	3 ³ / ₄	7/16	725	31
4 - 5	5/8	2 ¹ / ₂	5	9/16	710	72
6	3/4	2 ¹ / ₂	5	9/16	860	70

Fig. 307 - Eye Socket

Size Range — 3/8" thru 7/8" rod

Material — Malleable Iron

Function — To provide a non-adjustable threaded connection for hanger rods when used with Fig. 303 Split Ring Hangers.

Approvals — Conforms to Federal Specification WW-H-171E, Type 16 and Manufacturers Standardization Society SP-69, Type 16.

Finish — Plain

Note — Available in Electro-Galvanized finish

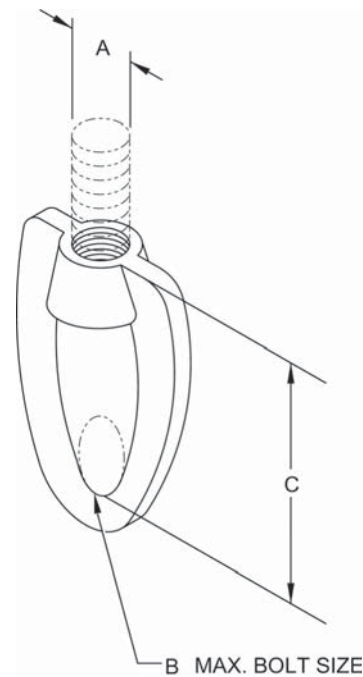

Dimensions • Weights

Pipe Size	Rod Size A	B	C	Max. Rec. Load Lbs.	Approx. Wt./100
1/2 - 2	3/8	1/4	1 ⁵ / ₁₆	570	7
2 ¹ / ₂ - 3 ¹ / ₂	1/2	1/4	1 ¹ / ₂	1130	13
4 - 5	5/8	3/8	1 ³ / ₄	1400	19
6	3/4	1/2	2 ¹ / ₈	1900	31
8	7/8	1/2	2 ³ / ₈	2200	44