

# 175 lb. WWP Iron Body Gate Valves

Fire Protection Valve • Bolted Bonnet • Indicator Post Pattern •  
Non-Rising Stem • Solid Wedge

**175 PSI/12.1 Bar Non-Shock Cold Water**

UL/ULC LISTED • FM APPROVED

## MATERIAL LIST

PART	SPECIFICATION
1. Nut	Steel ASTM A 307
2. Square Oper. Nut	Cast Iron ASTM A 126 Class B
3. Stem	Brass ASTM B 16 Alloy C36000
4. Ind. Post Flange Nut	Steel ASTM A 307
5. Ind. Post Flange	Cast Iron ASTM A 126 Class B
6. Ind. Post Flange Bolt	Steel ASTM A 307
7. O-Ring Seal	Buna-N Rubber
8. Bonnet	Cast Iron ASTM A 126 Class B
9. Ind. Post Flange Gasket	Non Asbestos
10. Body Bolt	Steel ASTM A 307
11. Body Gasket	Non Asbestos
12. Body Nut	Steel ASTM A 307
13. Body	Cast Iron ASTM A 126 Class B
*14. Wedge Bushing	Cast Bronze B 584 Alloy C84400
15. Wedge	Cast Bronze ASTM A 126 Class B
16. Wedge Face Ring	Cast Bronze B 584 Alloy C84400
17. Seat Ring	Cast Bronze B 584 Alloy C84400

\*Sizes 8", 10" and 12" only

## DIMENSIONS—WEIGHTS—QUANTITIES

Size	F-609 Dimensions										Weight		
	A		B		C		D		E		Lbs.	Kg.	
In. mm.	In.	mm.	In.	mm.	In.	mm.	In.	mm.	In.	mm.			
4	100	9.00	229	14.13	359	9.00	229	.94	24	3.66	93	105	48
6	150	10.50	267	18.56	471	11.00	279	1.00	25	2.25	57	170	77
8	200	11.50	292	22.13	562	13.50	343	1.13	29	4.00	102	277	125
10	250	13.00	330	25.75	654	16.00	406	1.19	30	3.88	98	399	181
12	300	14.00	356	29.50	749	19.00	483	1.25	32	4.94	125	623	283

Size	M-609 Dimensions										Weight		
	A		B		C		D		E		Lbs.	Kg.	
In. mm.	In.	mm.	In.	mm.	In.	mm.	In.	mm.	In.	mm.			
4	100	9.25	235	14.13	359	9.00	229	1.00	25	3.66	93	100	45
6	150	10.75	273	18.56	471	11.09	282	1.03	26	2.25	57	153	69
8	200	11.50	292	22.13	562	13.31	338	1.09	28	4.00	102	250	113
10	250	13.00	330	25.75	654	15.63	397	1.13	29	3.88	98	390	176
12	300	14.00	356	29.50	749	18.00	457	1.25	32	4.94	125	556	253



**F-609**  
Flanged



**M-609**  
Mechanical

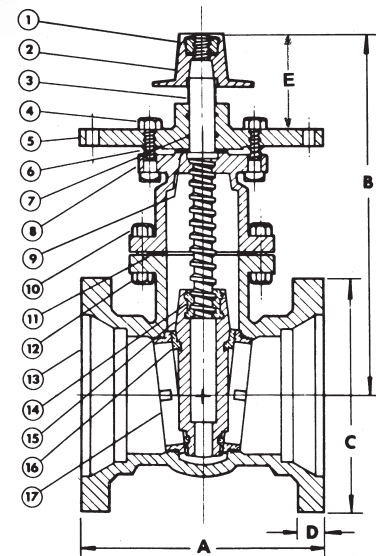

**M-609**  
MJ x MJ

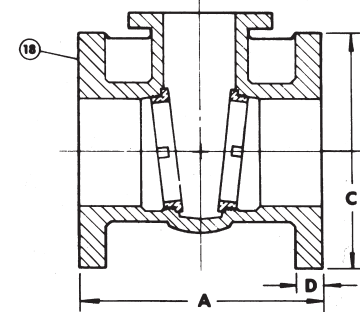

**F-609**  
Flg x Flg

**FREEZING WEATHER PRECAUTION:** Subsequent to testing a piping system, gate valve should be in an open position to allow complete drainage.

**NOTE:** Number of turns required to open 4", 9", 6", 13½", 8", 17½", 10", 30¼", 12", 38¼ turns. Tolerance ± ½ turn on all sizes.

**NOTE:** Available to ISO Flange dimensions. Specify F-609-I. See page 51.

