

THG-51E & THG-51SG Handicap Gates

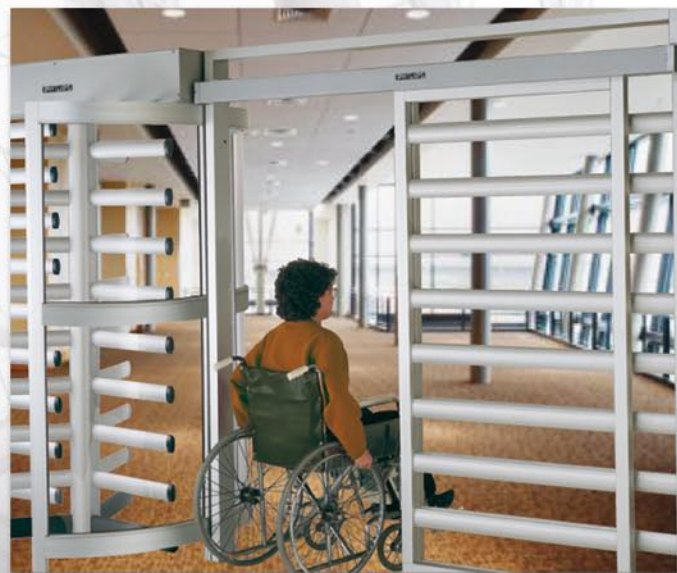

Full Security Access for Special Needs

Ideal for high security areas, Boon Edam's THG-51E and THG-51SG full height gates allow access for those with special needs. These two options offer an ideal solution for diverse logistical needs.

THG-51E 7' Full Security Handicap Gate

Designed for use with full security turnstiles and access control systems, this electrically operated gate offers a self-closing feature via overhead transom.

THG-51SG Sliding Handicap Gate

This one-direction sliding gate is designed for use with full height turnstiles and allows automatic entry, in conjunction with an access control system.

Construction, Features & Technical Characteristics

THG-51E

- Designed to provide handicap access into locations using full security turnstiles and access control systems
- Electrically operated by a 24 VDC doorstrike; magnetic lock also available
- Can be self-closing via a transom-mounted overhead closer
- Construction is a 2" square buck with interior door panel frame fabricated from 2" square tubing with round horizontal members
- Gate swings 90° with gate panel attached to the buck by a continuous stainless steel hinge
- Material/finish options include hot-dipped galvanized steel (THG-51EC), powder coated steel (THG-51ECP), anodized aluminum with stainless steel arms (THG-51EA) or complete stainless steel (THG-51ES)
- Construction materials generally match the turnstiles
- Lexan® gates (THG-51EL) use full 3/8" thick panel instead of horizontal bars
- Gate height of 86" matches turnstiles
- Opening clearance of 34" exceeds minimum ADA requirements
- Overall dimensions can be customized for specific applications

THG-51SG

- Provides sliding gate access for handicapped personnel
- Fully compliant with current ADA guidelines
- Overhead mounted gate operator allows touch free use by presenting proper credentials to the access control system
- When fully open, the sliding gate provides a 36" clearance
- Fabricated from anodized aluminum, the THG-51SG provides the perfect ADA-compliant complement to the THT-100ASTG full height turnstile series; available in matching finishes

Dimensions

Model THG-51E & 51EL

Overall Height	Overall Width	Barrier Height	Barrier Width	Weight
86"	40"	83"	34"	150 lbs.

Model THG-51SG

Overall Height	Overall Full Width	Gate Opening	Weight
83.5"	84"	36"	450 lbs.

THG-51E FOOTPRINT

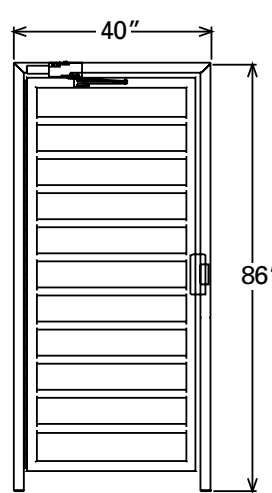

THG-51 EL FOOTPRINT

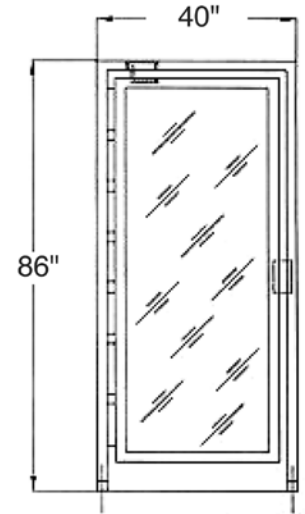

THG-51SG FOOTPRINT

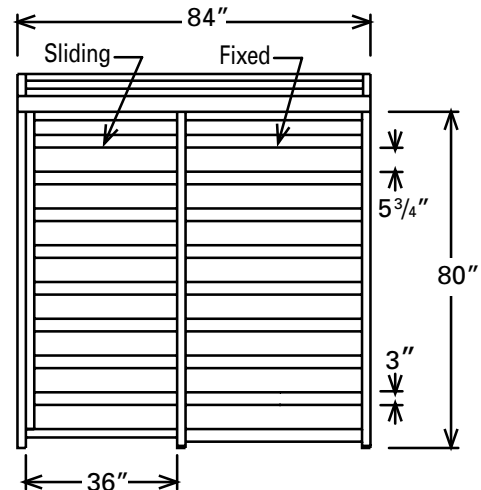

51-0107