

250 lb. WWP Iron Body Gate Valves

Fire Protection Valve • Bolted Bonnet • Indicator Post Pattern • Non-Rising Stem •
Resilient Wedge • Epoxy Coated Interior/Exterior

250 PSI/17.2 Bar Non-Shock Cold Working Pressure
(160° F/71° C max. operating temperature)

UL/ULC LISTED • FM APPROVED •
AWWA C-509 & 515 • NEW YORK CITY
M.E.A. APPROVED 236-93A

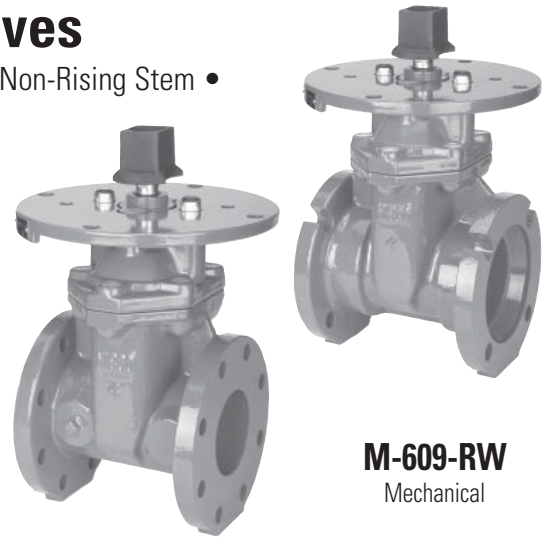

M-609-RW
Mechanical

F-609-RW
Flanged

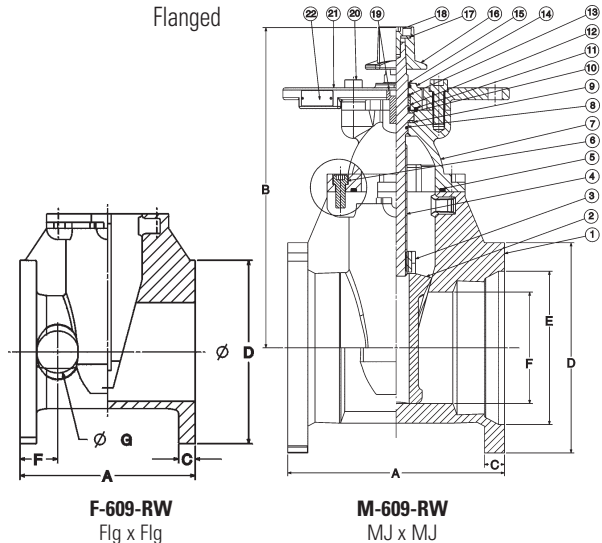

MATERIAL LIST	
PART	SPECIFICATION
1. Valve Body	Ductile Iron ASTM A 536
2. Resilient Wedge	Ductile Iron ASTM A 536/EPDM ASTM D 2000
3. Wedge Nut	Bronze ASTM B 584 UNS C83600
4. Stem	Bronze ASTM B 150 UNS C61400
5. Bonnet Gasket	EPDM ASTM D 2000
6. Bonnet Screw	(F) Alloy Steel ASTM A 574M Zinc Plated (M) 18-8 Stainless Steel ASTM 193
7. Bonnet	Ductile Iron ASTM A 536
8. Stem Primary O-Ring	EPDM ASTM D 2000
9. Stem Thrust Washer (lower)	Bronze ASTM B 584 UNS C83600
10. Stem Thrust Washer (upper)	Stainless Steel ASTM A 276 UNS S41000
11. Gland Seal O-Ring	EPDM ASTM D 2000
12. Stem Seal Bushing	Bronze ASTM B 584 UNS C83600
13. Stem Secondary O-Ring	EPDM ASTM D 2000
14. Gland Flange	Ductile Iron ASTM A 536
15. Stem Ring Wiper	EPDM ASTM D 2000
16. Square Operating Nut	Cast Iron ASTM A 126-B
17. Operating Nut Washer	Carbon Steel Zinc Plated
18. Operating Nut Screw	Alloy Steel ASTM A 574M Zinc Plated
19. Gland Flange Screw	Alloy Steel ASTM A 574M Zinc Plated
20. Indicator Flange Screw	Alloy Steel ASTM A 574M Zinc Plated
21. Indicator Post Flange	Ductile Iron ASTM A 536
22. UL/FM Label	Aluminum

NOTE: Body, Bonnet and Ind. Post Flange coated with electrostatically applied fusion bonded epoxy resin inside and outside per AWWA C-550.
Epoxy NSF and FDA certification

DIMENSIONS—WEIGHTS—QUANTITIES

M-609-RW Dimensions														Bolt					
Size	A		B		C		D		E		F		Circle	Flange	Turns	Weight			
In. mm.	In.	mm.	In.	mm.	In.	mm.	In.	mm.	In.	mm.	In.	mm.	In.	mm.	Holes	To Open	Lbs.	Kg.	
4	100	10.0	254	13.5	344	1.00	26	9.1	232	6.0	153	3.9	100	7.50	191	4	13.0	89	40
6	150	11.5	292	17.4	441	1.06	27	11.1	283	8.1	206	5.9	150	9.50	241	6	15.7	132	60
8	200	11.5	292	20.8	529	1.12	28	13.4	340	10.3	261	7.9	200	11.75	298	6	17.3	190	86
10	250	13.0	330	24.2	614	1.18	30	15.7	400	12.3	313	9.8	250	14.00	356	8	21.4	287	130
12	300	14.0	356	27.6	700	1.25	32	18.0	456	14.4	367	11.8	300	16.25	413	8	25.3	408	185

F-609-RW Dimensions														Bolt					
Size	A		B		C		D		F		G		Circle	Flange	Turns	Weight			
In. mm.	In.	mm.	In.	mm.	In.	mm.	In.	mm.	In.	mm.	In.	mm.	In.	mm.	Holes	To Open	Lbs.	Kg.	
4	100	9.0	229	13.5	344	0.94	24.0	9.0	229	2.13	54	2.1	54	7.50	191	8	13.0	91	41
6	150	10.5	267	17.4	441	1.00	25.4	11.0	279	2.24	57	2.5	64	9.50	241	8	15.6	142	65
8	200	11.5	292	20.8	529	1.13	28.6	13.5	343	2.48	63	2.8	70	11.75	298	8	17.3	216	98
10	250	13.0	330	24.2	614	1.19	30.2	16.0	406	2.56	65	2.8	70	14.25	362	12	21.4	314	143
12	300	14.0	356	27.6	700	1.25	31.8	19.0	483	2.91	74	3.4	86	17.00	432	12	25.3	446	203



FREEZING WEATHER PRECAUTION: Subsequent to testing a piping system, gate valve should be in an open position to allow complete drainage.