

Bronze Check Valves

Horizontal Swing • Regrinding Type • Y-Pattern • Renewable Seat and Disc

125 PSI/9 Bar Saturated Steam to 353° F/178° C
200 PSI/14 Bar Non-Shock Cold Working Pressure

CONFORMS TO MSS SP-80

MATERIAL LIST

PART	SPECIFICATION
1. Bonnet	Bronze ASTM B 62
2. Body	Bronze ASTM B 62
3. Hinge Pin	Bronze ASTM B 140 Alloy C31400 or B 134 Alloy C23000
4. Disc Hanger	Bronze ASTM B 62 or 304 Stainless Steel ¼" thru ¾"
5. Hanger Nut	Bronze ASTM B 16
6. Disc Holder	Bronze ASTM B 62
7. Seat Disc	Water, Oil or Gas (Buna-N) (W) Steam (TFE) (Y) Bronze ASTM B 62 (B) Viton® (V)
8. Seat Disc Nut	Bronze ASTM B 16 or B 62
9. Hinge Pin Plug	Bronze ASTM B 140 Alloy C32000 (Not shown)
*10. Seat Disc Washer	ASTM B 98 Alloy C65500 or ASTM B 103

*Sizes ¾", 1", 1¼", 1½" and 2" only

Size	Dimensions						T-113		S-113		
	A		B		C		Lbs.	Kg.	Lbs.	Kg.	
In. mm.	In.	mm.	In.	mm.	In.	mm.					
1/4	8	2.13	54	1.63	41	1.38	35	0.50	0.23	0.51	0.23
3/8	10	2.13	54	1.63	41	1.31	33	0.47	0.22	0.48	0.22
1/2	15	2.44	62	1.69	43	1.50	38	0.55	0.25	0.55	0.25
3/4	20	2.94	75	1.88	48	1.88	58	0.90	0.41	0.88	0.40
1	25	3.56	90	2.31	59	2.25	57	1.46	0.66	1.48	0.67
1¼	32	4.19	106	2.69	68	2.75	70	2.17	0.99	2.22	1.01
1½	40	4.50	114	2.94	75	3.13	79	2.95	1.34	3.00	1.36
2	50	5.25	133	3.94	100	3.75	95	4.79	2.17	4.87	2.21
*2½	65	8.00	203	5.06	129	5.06	129	11.48	5.21	10.48	4.76
*3	80	9.25	235	6.25	159	6.25	159	17.53	7.96	15.29	6.94

Ordering: T-413 and S-413 normally furnished with Bronze Disc (T-413-B) or (S-413-B)
Both available with TFE Steam Disc (T-413-Y), (S-413-Y) or CSP Disc (T-413-W), (S-413-W)
or 300°F 67 PSI steam Viton Disc (T-413-V).

* Class 150 (433) furnished for these sizes.

NIBCO check valves may be installed in both horizontal and vertical lines with upward flow or in any intermediate position. They will operate satisfactorily in a declining plane (no more than 15°).

Warning – Do Not Use For Reciprocating Air Compressor Service.

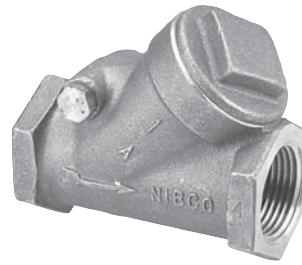

T-413
Threaded

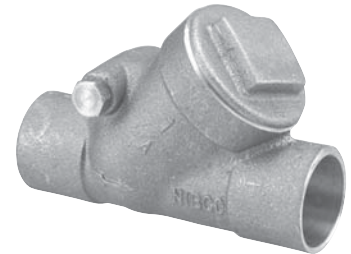

S-413
Solder

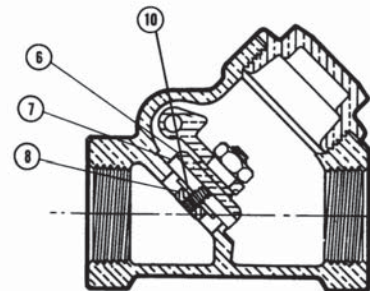

T-413-B
NPT x NPT

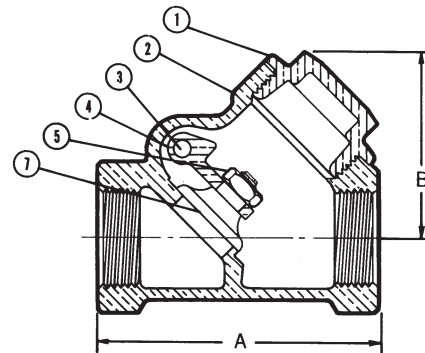

T-413-Y
NPT x NPT

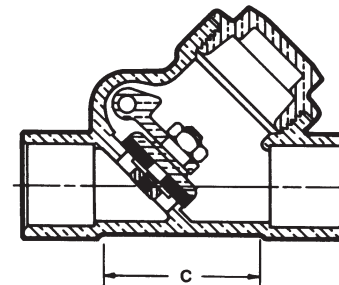

S-413-W
Cup x Cup