

Fig. 5H - Heavy Duty Double Bolt Pipe Clamp

Size Range — 6" thru 36" pipe.

Material — Carbon Steel

Function — Recommended for the suspension of heavy duty high temperature pipe runs requiring up to 4" of insulation and where flexibility of the clamp may be necessary. Use with Fig. 330 Weldless Eye Nut, Fig. 102 Eye Rod or Fig. 101 Welded Eye Rod.

Approvals — Conforms to Federal Specification WW-H-171E, Type 3 and Manufacturers Standardization Society SP-69, Type 3.

Maximum Temperature — 750°F

Finish — Plain

Note — Available in Electro-Galvanized and HDG finish or Stainless Steel materials.

Order By — Figure number, pipe size and finish.

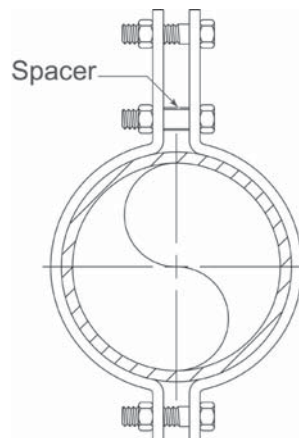
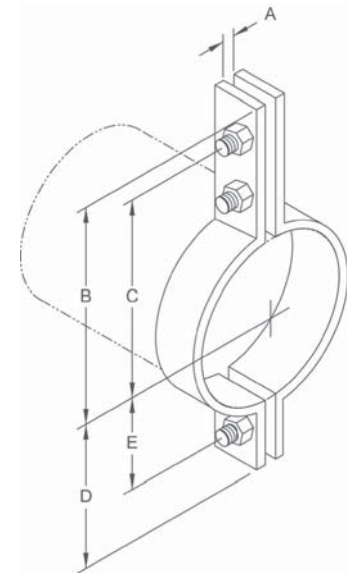

Dimensions • Weights

| Pipe Size | A | B | C | D | E | Bolt Size | Max. Design Load Lbs. | | Approx. Wt./100 |
|-----------|----|-------------------|---------------------------------|--------------------------------|--------------------------------|-----------|------------------------|-------|-----------------|
| | | | | | | | For Service Temp. 650° | 750°F | |
| 6 | 1¾ | 10¾ ₁₆ | 8 ¹⁵ / ₁₆ | 6 | 4¾ | 1 | 3500 | 3125 | 1200 |
| 8 | 2 | 11¾ | 10 ¹ / ₈ | 7¼ | 6 | 1½ | 4800 | 4285 | 1850 |
| 10 | 2¼ | 13¾ | 11¾ | 9 | 7¼ | 1¼ | 5500 | 4910 | 3030 |
| 12 | 2½ | 14¾ ₁₆ | 12 ⁹ / ₁₆ | 10¾ | 8 ⁵ / ₈ | 1¾ | 7000 | 6250 | 4200 |
| 14 | 2½ | 15½ | 13½ | 11¾ | 9 ⁵ / ₈ | 1½ | 9500 | 8485 | 6000 |
| 16 | 3 | 17¾ | 14 ⁷ / ₈ | 13¾ | 10 ⁷ / ₈ | 1¾ | 10000 | 8930 | 8000 |
| 18 | 3½ | 18¼ | 16¼ | 14½ | 12½ | 2 | 13800 | 12325 | 11500 |
| 20 | 3½ | 19¾ | 17¼ | 16 | 13½ | 2 | 15300 | 13665 | 14000 |
| 24 | 3½ | 22¾ | 19 ⁵ / ₁₆ | 18½ | 15½ | 2 | 16300 | 14555 | 19000 |
| 30 | 4¼ | 32¾ | 28¼ | 24¾ | 19 ⁷ / ₈ | 2¼ | 20500 | — | 40600 |
| 36 | 4½ | 40¼ | 34¾ | 30 ¹ / ₈ | 22 ⁵ / ₈ | 2¾ | 28000 | — | 67800 |

Based on allowable stresses shown in the ANSI code for pressure piping.