

# 175 lb. WWP Bronze Angle Valves

Fire Protection Valve • Threaded Ends • Rubber Disc • Screw Over Bonnet

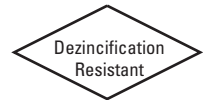

175 PSI/12.1 Bar Non-Shock Cold Water

UL LISTED\*

## MATERIAL LIST

PART	SPECIFICATION
1. Handwheel	Aluminum
2. Handwheel Screw	Carbon Steel (1/2" & 3/4") Stainless Steel (1")
3. Stem	Bronze ASTM B 584 Alloy C84400
4. Packing Nut	Bronze ASTM B 584 Alloy C83600 or ASTM B 16
5. Packing	Graphite Impregnated (Non Asbestos)
6. Bonnet	Bronze ASTM B 584 Alloy C84400
7. Body	Bronze ASTM B 584 Alloy C84400
8. Seat Disc	Nitrile Rubber
9. Seat Screw	Stainless Steel
10. Pack Washer	Sheet Brass



**KT-67-UL**  
Threaded

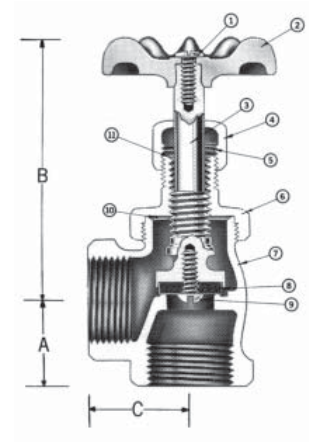

**KT-67-UL**  
NPT x NPT

## DIMENSIONS—WEIGHTS—QUANTITIES

Size	Dimensions						Weight		Box Qty.	Master Ctn. Qty.	
	A		B		C		Lbs.	Kg.			
In. mm.	In.	mm.	In.	mm.	In.	mm.					
1/2	15	.94	24	3.25	83	1.06	27	.62	.28	10	60
3/4	20	1.02	26	3.12	79	1.20	30	.70	.32	10	60
1	25	1.80	46	4.50	114	1.62	41	1.57	.71	5	25

\*UL Listed for Trim and Drain Use.

