



PLUG GATE VALVES



Sample Engineering Specification

All thermoplastic valves shall be Plug Gate style constructed from PVC Type I, ASTM D 1784 Cell Classification 12454 or CPVC Type IV, ASTM D 1784 Cell Classification 23447, with Polypropylene bonnets and high impact Polypropylene hand wheel. All valves shall have non-rising stem and Plug-style Polyethylene gate with Strain-Equalizing thread. All valve components shall be replaceable. All 1/2" - 2" valves shall be pressure rated to 235 psi and all flanged valves 1/2" - 6" to 150 psi for water @ 73°F, as manufactured by Spears® Manufacturing Company.

Features – PVC, CPVC

Spears® Plug Gate Valve utilizes a cylindrical “plug-style” gate for more uniform sealing and positive shutoff. Low-profile, compact design and non-rising stem saves space for the most demanding applications. Spears® Strain-Equalizing stem/wedge design combined with improved Polypropylene bonnet makes this one of the most reliable thermoplastic gate valves available. Valves are produced from PVC or CPVC bodies in IPS sizes of 1/2" - 2" with Socket & SR Threaded or 1/2" - 6" Flanged end connections.

- Chemical & Corrosion Resistant PVC or CPVC Construction with Polypropylene Bonnet
- Polyethylene Plug-Style Gate Provides Cylindrical Internal Seal
- Non-Rising Stem with Patented Strain-Equalizing Threads
- 6" Valve Features Built-in Position Indicator
- High-Impact Polypropylene Hand Wheel
- Fully Serviceable In-line with Repair Kits or Full Internal Replacement Cartridges
- Buna-N, EPDM or Viton® O-ring Seals
- Sizes 1/2" – 2" Pressure Rated to 235 psi @ 73°F Flanged through 6" to 150 psi @ 73°F
- Suitable for Vacuum Service
- Assembled with Silicone-Free, Water Soluble Lubricants
- Optional 2" Square/T-Style Operator Nut available.

Quick-View Valve Selection Chart

Valve Size	O-ring Material	PVC Part Numbers ¹			Pressure Rating	
		Socket	SR Threaded	Flanged		
1/2	Buna-N	5212-005	5211-005SR	5213-005	235 psi Non-Shock Water @ 73°F	
	EPDM	5222-005	5221-005SR	5223-005		
	Viton®	5232-005	5231-005SR	5233-005		
3/4	Buna-N	5212-007	5211-007SR	5213-007		
	EPDM	5222-007	5221-007SR	5223-007		
	Viton®	5232-007	5231-007SR	5233-007		
1	Buna-N	5212-010	5211-010SR	5213-010		
	EPDM	5222-010	5221-010SR	5223-010		
	Viton®	5232-010	5231-010SR	5233-010		
1-1/4	Buna-N	5212-012	5211-012SR	5213-012		(Flanged 150 psi Non-Shock Water @ 73°F)
	EPDM	5222-012	5221-012SR	5223-012		
	Viton®	5232-012	5231-012SR	5233-012		
1-1/2	Buna-N	5212-015	5211-015SR	5213-015		
	EPDM	5222-015	5221-015SR	5223-015		
	Viton®	5232-015	5231-015SR	5233-015		
2	Buna-N	5212-020	5211-020SR	5213-020		
	EPDM	5222-020	5221-020SR	5223-020		
	Viton®	5232-020	5231-020SR	5233-020		
6	EPDM	---	---	5223-060		
	Viton®	---	---	5233-060		

1: For CPVC valves, add the letter "C" to the part number (e.g; 5222-005C, 5211-005CSR)

Plug Gate Valve O-ring Repair Kit

All kits include Stem O-ring (2), Bonnet O-ring (1).

Valve Size	Part Number		
	Buna-N O-ring	EPDM O-ring	Viton® O-ring
1/2, 3/4 & 1	PGT-BRK-010	PGT-ERK-010	PGT-VRK-010
1-1/4, 1-1/2 & 2	PGT-BRK-020	PGT-ERK-020	PGT-VRK-020
6	---	PGT-ERK-060	PGT-VRK-060

Plug Gate Valve Internal Replacement Cartridge

Internal Replacement Cartridge includes complete, fully assembled Handle Nut, Stem O-ring, Bonnet O-ring, and Gate for direct insertion into existing valve body.

Valve Size	Part Number					
	Buna-N O-rings	CPVC w/ Buna-N O-rings	EPDM O-rings	CPVC w/ EPDM O-rings	Viton® O-rings	CPVC w/ Viton® O-rings
1/2, 3/4 & 1	5210-010	5210-010C	5220-010	5220-010C	5230-010	5230-010C
1-1/4, 1-1/2 & 2	5210-020	5210-020C	5220-020	5220-020C	5230-020	5230-020C
6	---	---	5220-060	5220-060C	5230-060	5230-060C

PLUG GATE VALVES

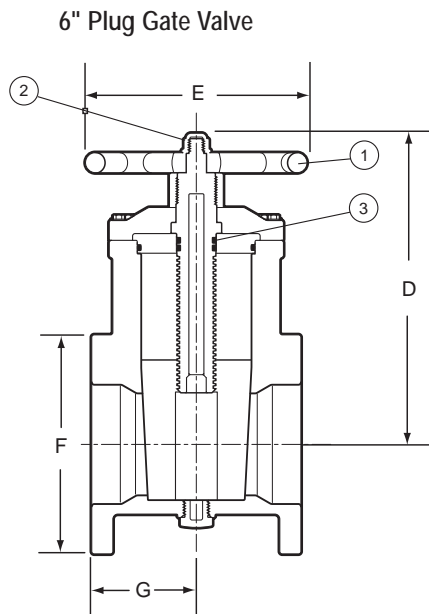

1/2" - 2" Plug Gate Valve

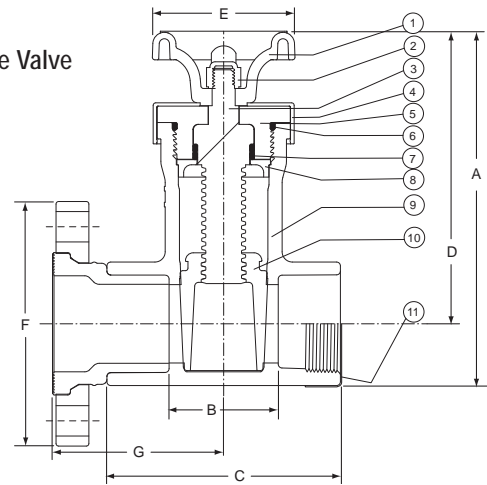

Replacement Parts

No	Component	Qty.	Material
1	Handwheel	1	PP
2	Nut	1	PVC
3	Stem O-Ring	2	EPDM, Viton®

Replacement Parts

No	Component	Qty.	Material
1	Handwheel	1	PP
2	Nut	1	PVC
3	Stem	1	PP
4	Bonnet Retainer	1	PVC
5	Bonnet	1	PP
6	Bonnet O-ring	1	Buna-N, EPDM, Viton®
7	Stem O-ring	2	Buna-N, EPDM, Viton®
8	Stem Support	1	PVC/CPVC
9	Body	1	PVC/CPVC
10	Gate	1	PE
11	SS Collar	2	SS 316

Dimensions & Weights

Nominal Size	Dimension Reference (inches)								Approx. Wt. (Lbs.)			
	A	B		C	D	E	F	G	PVC		CPVC	
		Socket	SR Thread						Soc/Thd	Flanged	Soc/Thd	Flanged
1/2	5	1-1/4	1-11/16	3-1/16	4-1/8	2-5/8	3-1/2	2-11/32	.38	.77	.39	.80
3/4	5	1-1/4	1-15/16	3-5/16	4-1/8	2-5/8	3-7/8	2-1/2	.40	.95	.41	.99
1	5	1-1/4	1-3/4	3-1/2	4-1/8	2-5/8	4-1/4	2-21/32	.43	1.21	.44	1.27
1-1/4	8-5/8	2-21/32	3-7/16	5-1/4	7-1/8	3-7/16	4-5/8	3-5/8	1.84	2.83	1.85	2.89
1-1/2	8-5/8	2-21/32	3-5/8	5-15/32	7-1/8	3-7/16	5	3-15/16	1.94	3.15	1.98	3.27
2	8-5/8	2-21/32	3-27/32	5-23/32	7-1/8	3-7/16	5-15/16	4-5/32	2.11	3.99	2.17	4.18
6	---	---	---	---	15-5/8	10-7/8	11	5-1/4	---	35.53	---	43.56

Temperature Pressure Rating

System Operating Temperature °F (°C)		100 (38)	110 (43)	120 (49)	130 (54)	140 (60)	150 (66)	160 (71)	170 (77)	180 (82)	190 (88)	200 (93)	210 (99)	
Valve Pressure Rating psi (MPa)	1/2" - 2"	PVC	235 (1.62)	140 (.97)	130 (.90)	90 (.62)	50 (.34)	-0 (-0)	-0 (-0)	-0 (-0)	-0 (-0)	-0 (-0)	-0 (-0)	
		CPVC	235 (1.62)	219 (1.51)	170 (1.17)	145 (1.00)	130 (.90)	110 (.76)	95 (.66)	80 (.55)	70 (.48)	60 (.41)	50 (.34)	-0 (-0)
	6"	PVC	150 (1.03)	130 (.90)	110 (.76)	60 (.41)	50 (.34)	-0 (-0)	-0 (-0)	-0 (-0)	-0 (-0)	-0 (-0)	-0 (-0)	-0 (-0)
		CPVC	150 (1.03)	140 (.97)	130 (.90)	120 (.83)	110 (.76)	100 (.69)	90 (.62)	80 (.55)	70 (.48)	60 (.41)	50 (.34)	-0 (-0)