

# 285 lb. WWP Ductile Iron Body Swing Check Valves

Fire Protection Valve • Raised Face Flanges • Bolted Bonnet • B 584 Bronze Trim

**285 PSI/19.7 Bar Non-Shock Cold Working Pressure**  
to -20° F to 100° F/-29° C to 38° C

TESTING SPECIFICATION TO MSS SP-71



**F-938-31**  
Flanged-Raised Face

## MATERIAL LIST

PART	SPECIFICATION
1. Bolt	Steel ASTM A 307
2. Identification Plate	Aluminum
3. Bonnet	Ductile Iron ASTM A 395
4. Body Gasket	Synthetic Fibres
5. Nut	Steel ASTM A 307
6. Side Plug	Bronze ASTM B 584
7. Hanger Pin	Bronze ASTM B 371
8. Hanger	Bronze ASTM B 584 or Ductile Iron ASTM A 536
9. Disc	Bronze ASTM B 584
10. Seat Ring	Bronze ASTM B 584
11. Disc Nut	Bronze ASTM B 371
12. Body	Ductile Iron ASTM A 395

## DIMENSIONS—WEIGHTS—QUANTITIES

Size	Dimensions										F-938-31 Weight	
	A		B		D		E		Lbs.	Kg.		
In.	mm.	In.	mm.	In.	mm.	In.	mm.	In.	mm.			
2	50	8.00	203	3.94	100	6.00	152	.63	16	24	11	
2½	65	8.50	216	4.50	114	7.00	178	.69	17	35	16	
3	80	9.50	241	5.13	130	7.50	191	.75	19	47	21	
4	100	11.50	292	6.13	156	9.00	229	.94	24	81	37	
5	125	13.00	330	6.81	173	10.00	254	.94	24	100	45	
6	150	14.00	356	8.00	203	11.00	279	1.00	25	146	66	
8	200	19.50	495	9.44	240	13.50	343	1.13	29	255	116	
10	250	24.50	622	12.06	306	16.00	406	1.19	30	426	193	
12	300	27.50	699	16.13	410	19.00	483	1.25	32	660	299	

Lever and Weight/Spring Options available.

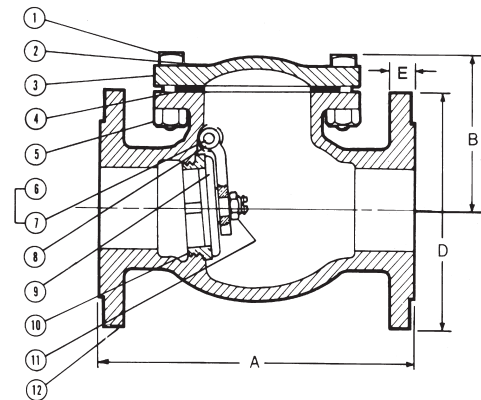

**F-938-31**  
Flg x Flg

NIBCO Check Valves may be installed in both horizontal and vertical lines with upward flow or in any intermediate position.

**WARNING: Do not use for Reciprocating Air Compressor Service.**