

LONG TANGENT 45° ELBOWS							
NOM. PIPE SIZE	OUTSIDE DIA. (O.D.)	CENTER TO FACE (A)	TANGENT LENGTH (L)	SCHEDULE 5		SCHEDULE 10	
				Wall Thick. (T)	Approx. Wt. Lbs.	Wall Thick. (T)	Approx. Wt. Lbs.
1/2	.840	1 7/8	1 1/4	.065	.18	.083	.24
3/4	1.050	1 15/16	1 1/2	.065	.27	.083	.34
1	1.315	2	1 3/8	.065	.32	.109	.52
1 1/4	1.660	2	1 1/4	.065	.38	.109	.64
1 1/2	1.900	2 3/16	1 1/4	.065	.48	.109	.78
2	2.375	2 3/4	1 1/2	.065	.73	.109	1.21
2 1/2	2.875	2 13/16	1 1/4	.083	1.20	.120	1.71
3	3.500	3 7/8	2	.083	1.87	.120	2.69
4	4.500	4 3/4	2 1/4	.083	2.96	.120	4.50
6	6.625	6	2 1/4	.109	7.50	.134	9.00

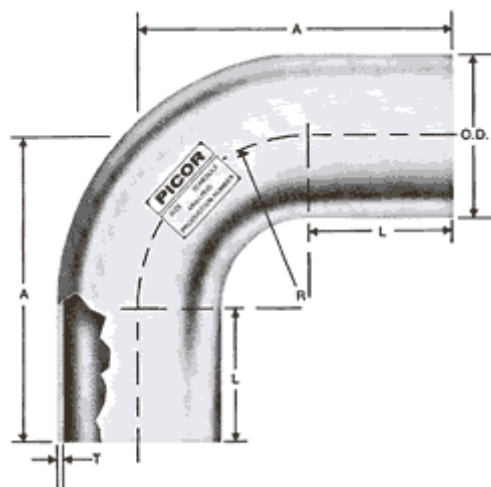

LONG TANGENT 90° ELBOWS								
NOM. PIPE SIZE	OUTSIDE DIA. (O.D.)	CENTER TO FACE (A)	TANGENT LENGTH (L)	RADIUS (R)	SCHEDULE 5		SCHEDULE 10	
					Wall Thick. (T)	Approx. Wt. Lbs.	Wall Thick. (T)	Approx. Wt. Lbs.
1/2	.840	2 3/4	1 1/4	1 1/2	.065	.22	.083	.29
3/4	1.050	2 5/8	1 1/2	1 1/8	.065	.33	.083	.40

1	1.315	2 7/8	1 3/8	1 1/2	.065	.39	.109	.63
1 1/4	1.660	3 1/8	1 1/4	1 7/8	.065	.46	.109	.77
1 1/2	1.900	3 1/2	1 1/4	2 1/4	.065	.61	.109	.99
2	2.375	4 1/2	1 1/2	3	.065	1.03	.109	1.72
2 1/2	2.875	5	1 1/4	3 3/4	.083	1.75	.120	2.50
3	3.500	6 1/2	2	4 1/2	.083	2.74	.120	3.94
4	4.500	8 1/4	2 1/4	6	.083	4.45	.120	6.40
6	6.625	11 1/4	2 1/4	9	.109	12.00	.134	14.00

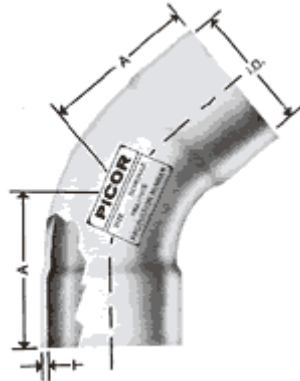

BELLED END 45° ELBOWS						
NOM. PIPE SIZE	INSIDE DIA. (I.D.)	CENTER TO FACE (A)	SCHEDULE 5		SCHEDULE 10	
			Wall Thick. (T)	Approx. Wt. Lbs.	Wall Thick. (T)	Approx. Wt. Lbs.
1/2	.840	1 13/16	.065	.18	.083	.24
3/4	1.050	1 7/8	.065	.27	.083	.34
1	1.315	1 15/16	.065	.32	.109	.52
1 1/4	1.660	1 15/18	.065	.38	.109	.64
1 1/2	1.900	2 1/8	.065	.48	.109	.78
2	2.375	2 11/16	.065	.73	.109	1.21
2 1/2	2.875	2 3/4	.083	1.20	.120	1.71
3	3.500	3 13/16	.083	1.87	.120	2.69
4	4.500	4 11/16	.083	2.96	.120	4.50
6	6.625	5 15/16	.109	7.50	.134	9.00

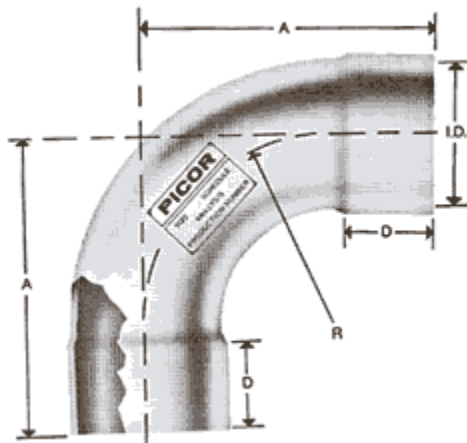

BELLED END 90° ELBOWS						

NOM. PIPE SIZE	INSIDE DIA. (I.D.)	RADIUS (R)	CENTER TO FACE (A)	SCHEDULE 5		SCHEDULE 10	
				Wall Thick. (T)	Approx. Wt. Lbs.	Wall Thick. (T)	Approx. Wt. Lbs.
1/2	.840	1 1/2	2 11/16	.065	.22	.083	.29
3/4	1.050	1 1/8	2 9/16	.065	.33	.083	.40
1	1.315	1 1/2	2 13/16	.065	.39	.109	.63
1 1/4	1.660	1 7/8	3 1/16	.065	.46	.109	.77
1 1/2	1.900	2 1/4	3 7/16	.065	.61	.109	.99
2	2.375	3	4 7/16	.065	1.03	.109	1.72
2 1/2	2.875	3 3/4	4 15/16	.083	1.75	.120	2.50
3	3.500	4 1/2	6 7/16	.083	2.74	.120	3.94
4	4.500	6	8 3/16	.083	4.45	.120	6.40
6	6.625	9	11 3/16	.109	12.00	.134	14.00

BACK

FOR AVAILABLE PRODUCTS [CLICK HERE](#)

[Our Story](#) | [Products](#) | [Capabilities](#) | [Picor: Chem/Pharm](#) | [Production Services](#) | [Contact Us](#) | [Price Sheets](#) | [Home](#)

Site designed and maintained by [Internet Chicago](#) © 1999-2004.