

Penn Machine

Class 6000 Threaded 90

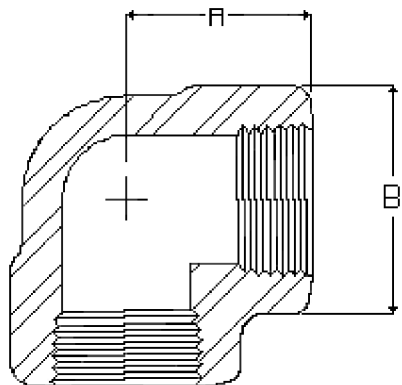

PENN CATALOG F2002 FIG NO. 06001
ASME-B16.11-2001

[Click here for the reducing fitting correct ordering practice](#)

Nominal Pipe Size	1/8"	1/4"	3/8"	1/2"	3/4"	1"	1-1/4"	1-1/2"	2"	2-1/2"	3"	3-1/2"
Dimension A	31/32	1-1/8	1-5/16	1-1/2	1-3/4	2	2-3/8	2-1/2	3-1/4	3-3/4	4-3/16	4-3/16
Dimension B	1-1/16	1-5/16	1-1/2	1-13/16	2-3/16	2-1/2	3	3-5/16	4	4-3/4	5-7/8	5-7/8
Approx. Wt. (lbs)	.35	.68	.95	1.72	2.76	3.79	6.66	8.39	13.74	23.24	36.22	32.60

Penn Machine

Class 6000 Threaded Tee

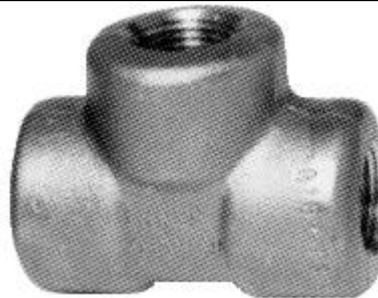
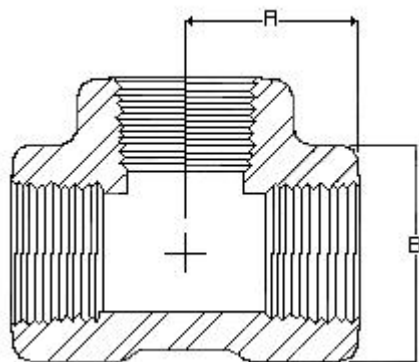

PENN CATALOG F2002 FIG NO. 06002
ASME-B16.11-2001

[Click here for the reducing fitting correct ordering practice](#)

Nominal Pipe Size	1/8"	1/4"	3/8"	1/2"	3/4"	1"	1-1/4"	1-1/2"	2"	2-1/2"	3"	3-1/2"
Dimension A	31/32	1-1/8	1-5/16	1-1/2	1-3/4	2	2-3/8	2-1/2	3-1/4	3-3/4	4-3/16	4-3/16
Dimension B	1-1/16	1-5/16	1-1/2	1-13/16	2-3/16	2-1/2	3	3-5/16	4	4-3/4	5-7/8	5-7/8
Approx. Wt. (lbs)	.44	.91	1.36	2.21	3.57	5.11	8.25	10.46	17.54	30.65	49.50	40.88

[Fitting catalog](#) | [Product catalog](#) | [Request quote/information](#) | [Home](#)

Web site created by Penn Machine. Send questions or comments to [James Friant](#).