



Center Line Resilient Seated Butterfly Valves Product Features

- Qualified for both gaseous and liquid service
- Positive shut-off bi-directionally
- Phenolic backed cartridge seat
- PTFE bushing standard
- Locking handle standard (2"-12")
- End of line service standard on lug style
- Ease of automation
- Field repairable (2"-24")
- Complete size range: 2 through 48 inches

Center Line has been a market leader in quarter-turn valves for more than 40 years, and we have earned a reputation as a supplier of superior valves at competitive prices. Our goal is to exceed industry requirements and customer expectations.

We are committed to offering products that meet a wide range of applications and requirements. We continually improve our product line by introducing new products and enhancing existing designs, providing our customers with the best products on the market.

Our complete line of resilient seated butterfly valves provides you with the reliability you need, backed by the guarantee that comes with using valves designed and produced in company-owned manufacturing facilities.

Typical Applications

- HVAC
- Chemical/ Petrochemical Processing
- Food and Beverage
- Power and Utilities
- Pulp and Paper

NOTE: In keeping with our policy of continuing improvement, we reserve the right to institute changes in design, material, dimensions, or specifications without notice and without incurring any obligation to make such changes and modifications on product previously or subsequently sold.

Resilient Seated Butterfly Valves



Series 200 – 225 – 250

Quality is designed into Series 200, 225, and 250 butterfly valves from Center Line. These valves feature a phenolic-backed cartridge seat and precision-machined parts to assure years of dependable operation.

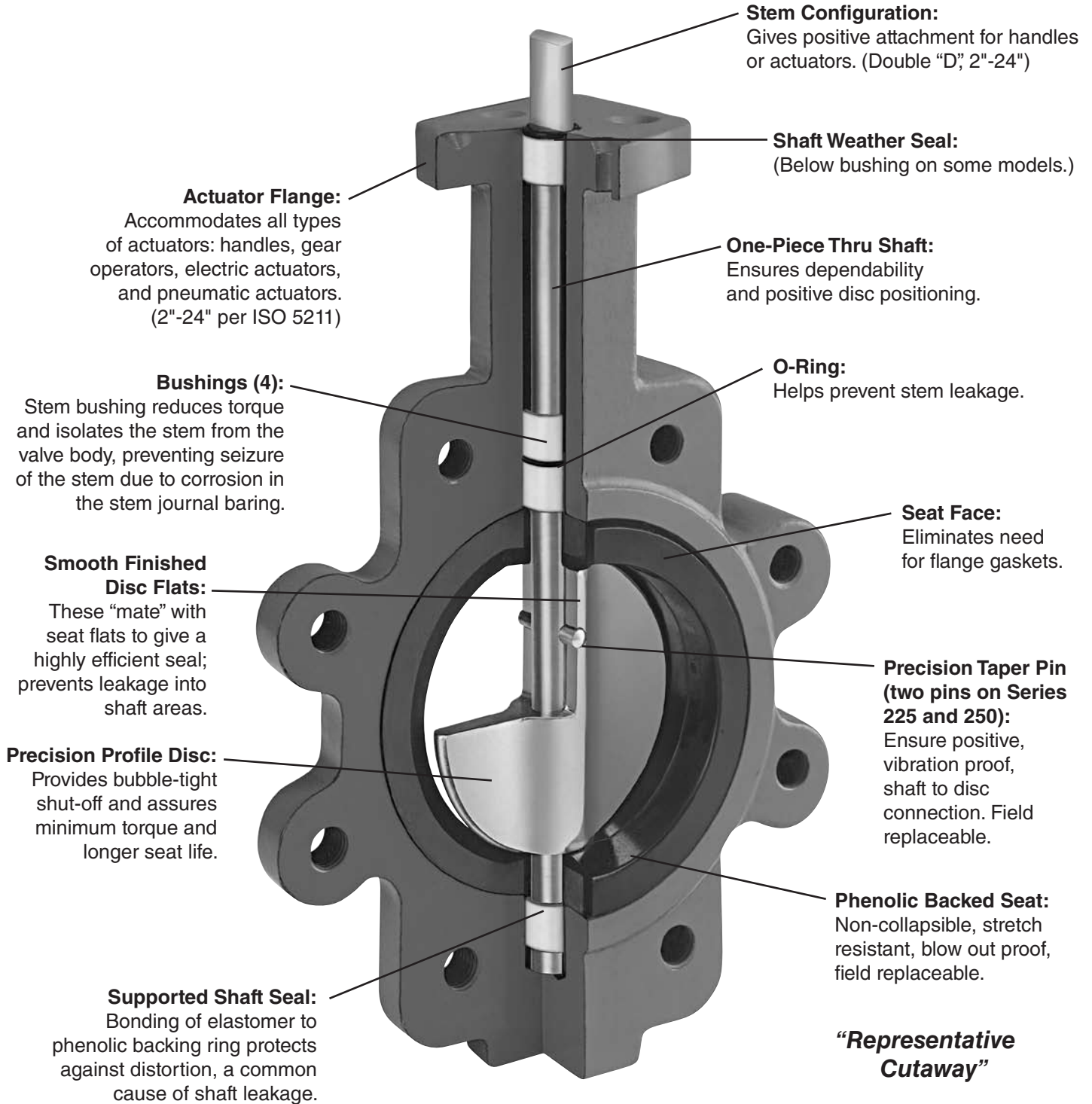



Resilient Seated Butterfly Valves

Series 200

- Available in sizes 2" to 48".
- Available in Wafer or Lug style body (2" to 30").
- Double flange available 28" to 48" valves.
- Wafer body features four alignment holes.
- Pressure ratings for tight shut-off at temperatures up to the maximum limit of the seat material:
 - 2" to 12" — 200 psi, 125 psi for PTFE seat.
 - 14" to 48" — 150 psi.
- Ideal for on-off or throttling services.
- Available with handles (2" to 12"), manual gear operators (2" to 48"), and electric or pneumatic actuators (2" to 48").
- Refer to Crane automation bulletin for details of pneumatic and electric actuators.
- Designed to comply with MSS SP-67.
- Compatible with ASME B16.1 and ASME B16.5 flanges.
- Valves 2" to 20" meet the intent and have passed the AWWA C-504-87 Section 5 proof of design tests.
- Type approval certification from ABS for marine applications (2" to 48").
- Bi-directional dead-end capability to 200 psi (2" to 12") and 150 psi (14" to 24") is standard on lug valves.
- Operators mounted perpendicular to pipe.
- For bolting information, consult the Center Line Installation and Maintenance Manual.
- Vacuum Service Rating: zero leakage at 24" of mercury.
- Commercial cleaning available for non-silicone and Oxygen level 2.
- PED Certification available for sizes 2" to 24".

Valve Seating Torques (In-Lbs.) 2" to 30"

Valve Size	Standard Disc Differential Pressure								Undercut Diff. Press.	
	50 PSI ΔP Bushing		100 PSI ΔP Bushing		150 PSI ΔP Bushing		200 PSI ΔP Bushing		75 PSI ΔP Bushing	
	Bronze	PTFE	Bronze	PTFE	Bronze	PTFE	Bronze	PTFE	Bronze	PTFE
2"	106	100	117	106	129	111	140	117	-	-
2 ½"	152	150	166	163	181	176	195	189	-	-
3"	213	207	230	220	248	232	265	244	-	-
4"	321	290	386	323	450	357	515	390	-	-
5"	481	423	598	481	715	540	832	598	-	-
6"	692	599	878	691	1,063	783	1,248	875	-	-
8"	1,326	1,060	1,716	1,183	2,106	1,307	2,496	1,430	1,124	819
10"	2,239	1,671	3,010	1,872	3,780	2,074	4,550	2,275	1,363	909
12"	3,959	2,568	4,953	2,795	5,948	3,023	6,942	3,250	2,457	1,445
14"	4,881	2,640	6,226	3,070	7,570	3,500	-	-	4,400	2,300
16"	7,020	4,260	8,580	4,880	10,140	5,500	-	-	5,900	3,600
18"	10,105	6,287	12,202	7,243	14,300	8,200	-	-	8,300	5,500
20"	13,923	8,360	16,582	9,180	19,240	10,000	-	-	11,100	6,700
24"	23,617	15,427	26,953	16,813	30,290	18,200	-	-	17,300	12,100
30"	39,721	27,313	43,391	29,407	47,060	31,500	-	-	27,300	21,100

Valve Seating Torques (In-Lbs.) 28" to 48" Double Flanged

Valve Size	Standard Disc Differential Pressure		
	50 PSI Wet / Dry	100 PSI Wet / Dry	150 PSI Wet / Dry
28"	23,718	26,639	28,957
30"	28,320	30,860	33,338
32"	32,418	35,073	38,126
36"	40,622	43,480	46,524
40"	68,924	74,048	78,995
42"	69,747	74,632	79,862
48"	96,598	103,837	111,112

All torques shown in these charts were derived from test data using water at 60°F. For torques using dry gases, multiply these numbers by 2.0. For torques involving other media, please consult the factory.

There is no safety factor included in the numbers shown on these charts. For actuator sizing, Crane recommends that these values be multiplied by 1.5 for single valve applications, or 2.0 for 3-way ("tee") applications.

For PTFE seats multiply the numbers shown by 2.0.

Under certain conditions, hydrodynamic torque can meet or exceed seating and unseating torques. When designing valve systems, hydrodynamic torque must be considered to help assure correct selection for the application.

Resilient Seated Butterfly Valves



Series 200

Seat Temperature Ratings

Material	Temperature Ratings °F
Buna-N	+10 to 180
Abrasive Resistant Buna-N	+10 to 180
Neoprene	+20 to 200
EPDM (2" - 16")	-30 to 275
EPDM (18" & Above)	-30 to 225
EPDM, Food Grade (2" - 12")	-30 to 225
Hypalon	0 to 275
Viton	+10 to 275
High Temp. Viton	+10 to 400
PTFE over Buna-N (125 psi, 2" - 12")	+40 to 250

Although elastomers have an effective operating temperature range, when used in valves, these ranges may have to be modified. The temperature ranges shown in the table have been adjusted accordingly.

For Low Temperature: While the seat materials selected for use in Center Line butterfly valves are capable of withstanding lower temperatures without damage, the durometer of the elastomer is changed. This “hardening” of the seat may increase the operating torque beyond the structural limits of the stem and/or the disc to stem configuration.

For High Temperature: When using High Temperature Viton, the operating pressure of the valve is reduced above 275°F.

Field Replacement: Replacing seats in sizes 12" - 20" is difficult and requires factory service. Sizes 24" and above cannot be field replaced.

C_v Values – Valve Sizing Coefficients (US-GPM @ 1ΔP) 2" to 48"

Size	10°	20°	30°	40°	50°	60°	70°	80°	90°
2"	0.06	3	7	15	27	44	70	105	115
2 ½"	0.10	6	12	25	45	75	119	178	196
3"	0.20	9	18	39	70	116	183	275	302
4"	0.30	17	36	78	139	230	364	546	600
5"	0.50	29	61	133	237	392	620	930	1022
6"	0.80	45	95	205	366	605	958	1437	1579
8"	2	89	188	408	727	1202	1903	2854	3136
10"	3	151	320	694	1237	2047	3240	4859	5340
12"	4	234	495	1072	1911	3162	5005	7507	8250
14"	6	338	715	1549	2761	4568	7230	10844	11917
16"	8	464	983	2130	3797	6282	9942	14913	16388
18"	11	615	1302	2822	5028	8320	13168	19752	21705
20"	14	791	1647	3628	6465	10698	16931	25396	27908
24"	22	1222	2587	5605	9989	16528	26157	39236	43116
28"	36	1813	3639	6636	10000	14949	22769	34898	49500
30"	37	2080	4406	9546	17010	28147	44545	66818	73426
32"	45	2387	4791	8736	13788	20613	31395	48117	38250
36"	260	3050	6730	12740	20220	32500	52500	79600	87500
40"	84	4183	8395	15307	24159	36166	55084	84425	119750
42"	350	4095	9040	17108	27150	43640	70500	106890	117500
48"	455	5365	11840	22400	30600	51200	92300	140000	154000

Series 200

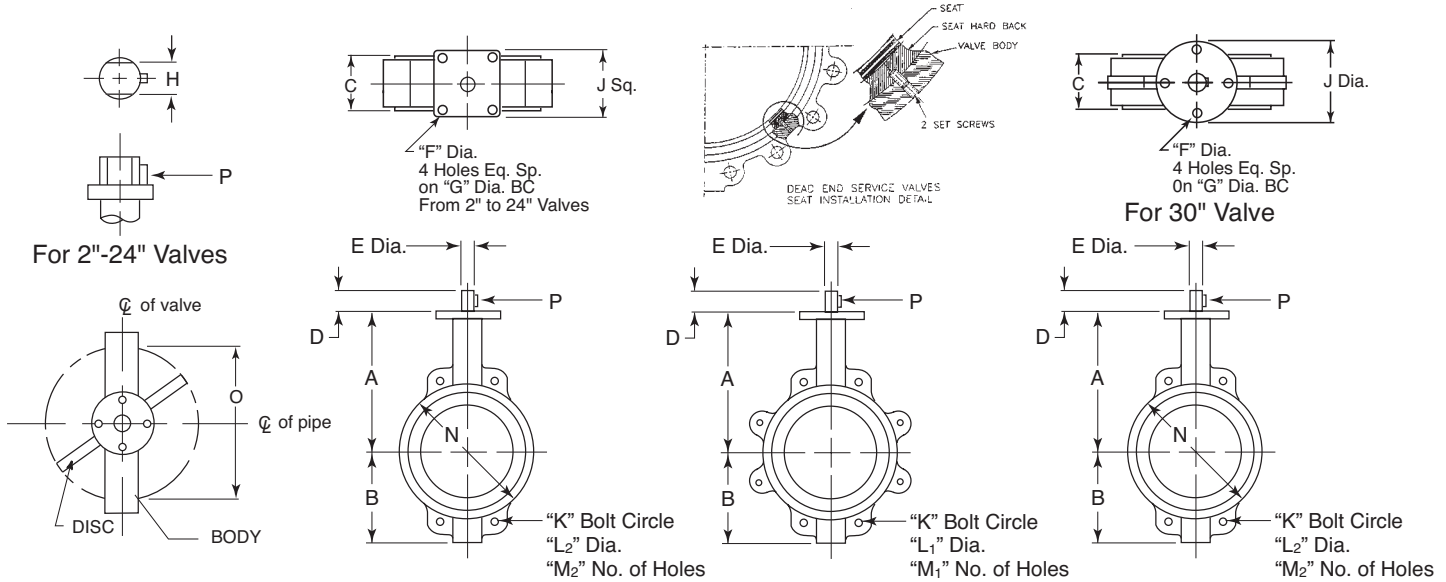

Dimensions 2" - 30" Wafer & Lug

For installation and maintenance instructions, please refer to the IOM manual available at www.cranevalvelit.com

Inches / mm	A	B	C	D	E	F	G	H	J	K	L ₁	L ₂	M ₁	M ₂	N	O	P
2" 50	6 3/8 161.93	3 1/4 82.55	1 3/4 44.45	1 1/4 31.75	1/2 12.70	3/8 9.53	2.76 70	0.39 10	2 3/4 69.85	4 3/4 120.65	5/8-11 17.46	1 1/16 17.46	4 4	4 4	4 101.60	1.26 32.0	Wooduff #3
2 1/2" 65	6 7/8 174.63	3 3/4 95.25	1 7/8 47.63	1 1/4 31.75	1/2 12.70	3/8 9.53	2.76 70	0.39 10	2 3/4 69.85	5 1/2 139.70	5/8-11 17.46	1 1/16 17.46	4 4	4 4	4 3/4 120.65	1.83 46.5	Wooduff #3
3" 80	7 1/8 180.98	4 101.60	2 1/8 47.63	1 1/4 31.75	1/2 12.70	3/8 9.53	2.76 70	0.39 10	2 3/4 69.85	6 152.40	5/8-11 17.46	1 1/16 17.46	4 4	4 4	5 1/8 130.18	2.54 64.5	Wooduff #3
4" 100	7 7/8 200.03	4 7/8 123.83	2 1/8 53.98	1 1/4 31.75	5/8 15.88	3/8 9.53	2.76 70	0.47 12	2 3/4 69.85	7 1/2 190.50	5/8-11 17.46	1 1/16 17.46	8 4	4 4	6 3/4 171.45	3.54 89.9	Wooduff #9
5" 125	8 3/8 212.73	5 3/8 136.53	2 1/4 57.15	1 1/4 31.75	3/4 19.05	3/8 9.53	2.76 70	0.55 14	2 3/4 69.85	8 1/2 215.90	3/4-10 20.64	1 3/16 20.64	8 4	4 4	7 3/4 196.85	4.36 110.7	Wooduff #9
6" 150	8 7/8 225.43	5 7/8 149.23	2 1/4 57.15	1 1/4 31.75	3/4 19.05	3/8 9.53	2.76 70	0.55 14	2 3/4 69.85	9 1/2 241.30	3/4-10 20.64	1 3/16 20.64	8 4	4 4	8 5/8 219.08	5.72 145.3	Wooduff #9
8" 200	10 1/4 260.35	7 3/4 196.86	2 1/2 63.50	1 3/4 44.45	7/8 22.23	7/16 11.11	4.02 102	0.67 17	3 3/4 95.33	11 3/4 298.45	3/4-10 20.64	1 3/16 20.64	8 4	4 4	10 3/8 268.29	7.6 193.0	Wooduff #9
10" 250	11 1/2 292.10	8 1/4 209.55	2 3/4 69.85	1 3/4 44.45	1 1/8 28.58	7/16 11.11	4.02 102	0.87 22	3 3/4 95.33	14 1/4 361.95	7/8-9 23.81	1 5/16 23.81	12 4	4 4	13 1/8 331.79	9.5 241.3	Wooduff #15
12" 300	13 1/4 336.55	9 3/4 247.65	3 1/8 79.38	1 3/4 44.45	1 1/4 31.75	7/16 11.11	4.02 102	0.95 24	3 3/4 95.33	17 431.80	7/8-9 23.81	1 5/16 23.81	12 4	4 4	16 1/8 409.58	11.45 290.8	Wooduff #15
14" 350	14 1/2 368.30	11 279.40	3 1/8 79.38	1 3/4 44.45	1 1/4 31.75	7/16 11.11	4.02 102	0.95 24	3 3/4 95.33	18 3/4 476.25	1-8 26.99	1 1/4 26.99	12 4	4 4	17 1/8 434.98	12.78 324.6	Wooduff #15
16" 400	15 3/4 400.05	12 304.80	3 1/2 88.90	2 50.80	1 5/8 33.34	7/8 22.23	6.50 165	1.06 27	6 1/2 165.10	21 1/4 539.75	1-8 26.99	1 1/4 26.99	16 4	4 4	20 508.00	14.97 380.2	5/16" Sq. x 1 1/4"
18" 450	16 5/8 422.28	15 381.00	4 1/4 107.95	2 50.80	1 1/2 38.10	7/8 22.23	6.50 165	1.06 27	6 1/2 165.10	22 3/4 577.85	1 1/8 - 7 31.75	1 1/4 31.75	16 4	4 4	21 3/8 542.93	16.83 427.5	3/8" Sq. x 1 1/2"
20" 500	18 7/8 479.43	14 5/8 371.48	5 1/4 133.35	2 3/4 63.50	1 5/8 41.28	7/8 22.23	6.50 165	1.26 32	6 1/2 165.10	25 635.00	1 1/8 - 7 31.75	1 1/4 31.75	20 4	4 4	23 3/8 592.14	18.67 474.2	3/8" Sq. x 1 3/4"
24" 600	22 1/8 561.98	18 457.20	6 1/8 155.58	2 3/4 69.85	2 50.80	7/8 22.23	6.50 165	1.42 36	6 1/2 165.10	29 1/2 749.30	1 1/4 - 7 31.75	1 1/4 31.75	20 4	4 4	27 1/8 708.03	22.62 574.5	1/2" Sq. x 2 1/4"
30" 750	25 1/2 647.70	24 1/4 615.95	6 3/4 171.45	3 1/2 82.55	2 1/2 63.50	7/8 22.23	8 1/2 215.90	N/A 285.75	11 1/4 285.75	36 914.40	1 1/4 - 7 31.75	1 1/4 31.75	28 4	4 4	34 3/8 873.13	28.6 726.4	5/8" Sq. x 2 5/8"

L₁ and M₁ refer to Lug style valves, L₂ and M₂ refer to Wafer Style. "C" dimension is listed with elastomer in the relaxed condition. Approximately 1/8" total compression is required for proper sealing with pipe flanges. Valves are designed for installation between ASME B16.1 Class 125 (Iron) and B16.5 Class 150 (Steel) flanges. Gaskets are not needed, and should not be used since the seat face seals against the mating flange. If the valve is to be installed in between any other flanges, consult your Center Line agent or the factory for additional information. Center Line recommends that a blind flange be used on end of line applications.

"O" dimension is the valve clearance dimension.

Resilient Seated Butterfly Valves



Series 200

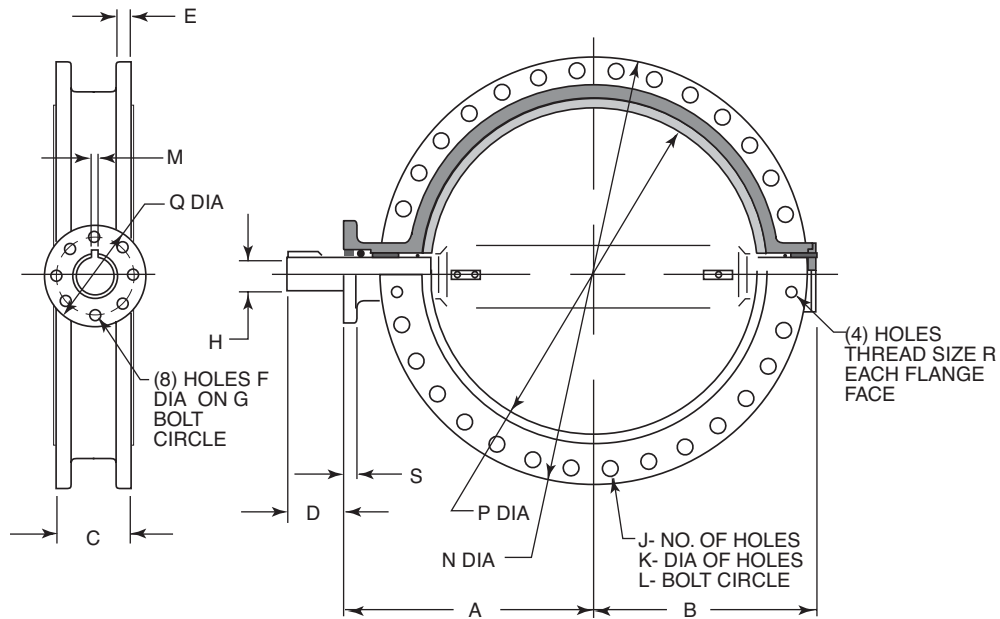

*Dimensions 28" - 48" Double Flanged

For installation and maintenance instructions, please refer to the IOM manual available at www.cranevalvelit.com

	A	B	C	D	E	F	G	H	J	K	L	M	N	P	Q	R	S
28 in	20.8	25	6.6	3.3	2.2	0.7	10	2.5	24	1.4	34	0.7 Sq.	37.1	27.8	11.8	1.25 - 7	1.3
mm	520	624	165	85	54	18	254	63.4	24	35	863.4	18 Sq.	927.1	695	300	-	33
30 in	26.4	22.4	6.7	3.4	2.2	0.7	10	2.5	24	1.4	36	0.7 Sq.	39.4	29.8	11.8	1.25 - 7	1.1
mm	660	560	167	86	54	18	254	63.4	24	35	914.4	18 Sq.	984	744	300	-	28
32 in	23.6	26.9	7.6	3.3	2.4	0.7	10	2.5	24	1.6	39.5	0.8 Sq.	42.4	31.8	11.8	1.5 - 6	1.3
mm	591	672	190	85	60.3	18	254	63.4	24	41.3	977.9	20 Sq.	1060.4	795	300	-	33
36 in	28.8	25.8	8.1	4.6	2.4	0.7	10	3	28	1.6	42.75	0.8 Sq.	47	34.0	11.8	1.5 - 6	1.3
mm	720	656	203	118	60.3	18	254	75	28	41.3	1085.8	20 Sq.	1169	864.7	300	-	33
40 in	28.8	32	8.7	5.1	2.4	0.7	10	3.3	32	1.6	47.25	0.9 Sq.	51.6	38.6	11.8	1.5 - 6	1.5
mm	721	800	218	130	60.3	18	254	85	32	41.3	1200.1	22 Sq.	1289	965	300	-	38
42 in	34.3	30.6	10	5.9	2.6	0.7	10	3.3	32	1.6	49.5	0.9 Sq.	53	40.5	11.8	1.5 - 6	1.4
mm	858	777.2	251	150	66	18	254	85	32	41.3	1257.3	22 Sq.	1346	1030	300	-	35
48 in	37.6	34	10.9	5.9	2.8	0.9	11.7	4.1	40	1.6	56	1.1 Sq.	59.5	45.7	13.8	1.5 - 6	1.5
mm	941	864	276.4	150	70	22	298	105	40	41.3	1422.4	28 Sq.	1511	1160	350	-	38

* Please note that dimensions apply to standard product only.

Weights 2" - 48" - lbs (kg)

	2"	2 1/2"	3"	4"	5"	6"	8"	10"	12"	14"	16"	18"	20"	24"	28"	30"	32"	36"	40"	42"	48"
Wafer	6 (2.7)	7 (3.2)	10 (4.5)	13 (5.9)	18 (8.2)	20 (9.1)	32 (14.5)	42 (19.1)	70 (31.7)	95 (43.1)	117 (53.1)	165 (74.8)	275 (124.7)	440 (199.6)	-	740 (335.7)	-	1660 (754)	-	2145 (975)	3023 (1374)
Lug	7 (3.2)	8 (3.6)	14 (6.4)	26 (11.8)	28 (12.7)	31 (14.1)	49 (22.2)	72 (32.7)	105 (47.6)	155 (70.3)	195 (88.5)	230 (104.3)	396 (179.6)	610 (276.7)	-	1050 (476.3)	-	-	-	-	-
Flanged	-	-	-	-	-	-	-	-	-	-	-	-	-	-	1173 (533)	1173 (533)	1525 (693)	1949 (886)	2141 (973)	2495 (1134)	3711 (1687)

NOTE: TECHNICAL DATA SUBJECT TO CHANGE WITHOUT NOTICE.

Series 200

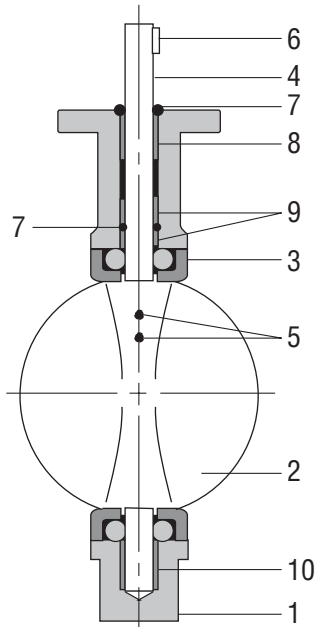

Sizes 2" - 30"

*Quantity of 3 pins required for sizes 30" and above

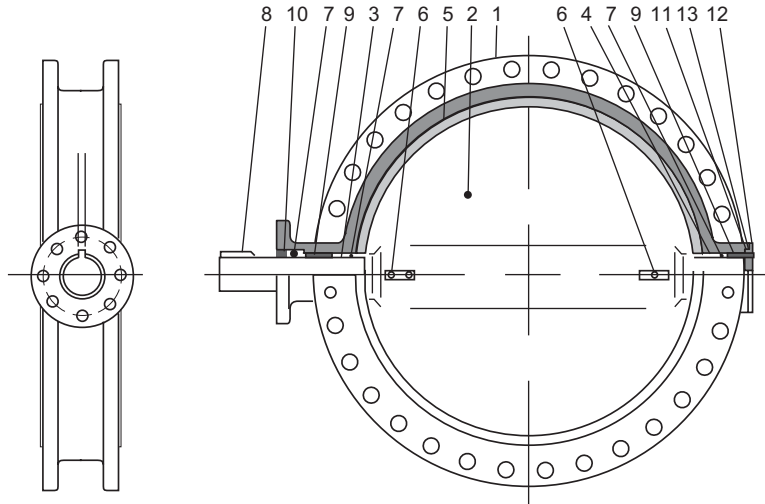

Sizes 28" - 48"

Bill of Materials 2" - 30"

Item	Description	Materials	Optional Materials
1	Body	Cast Iron	Ductile Iron
2	Disc	Ductile Iron†	Aluminum Bronze, 316 SS, Monel
3	Seat	Buna-N or EPDM	Neoprene, Hypalon, Viton, PTFE, FDA, Abrasion Resistant
4	Shaft	416 Stainless Steel	316 Stainless Steel, Monel
5	Taper Pin	300 Series Stainless	Monel
6	Key	Carbon Steel	No Option Available
7	O-Ring	Buna-N	No Option Available
8	Bushing	PTFE	Luberized Bronze
9	Bushing	PTFE	Luberized Bronze
10	Bushing	PTFE	Luberized Bronze

†ENP plated for 2"-12" valves

Bill of Materials 28" - 48"

Item	Description	Materials	Optional Materials
1	Body	Ductile Iron	No Option Available
2	Disc	Ductile Iron	Aluminum Bronze, 316 Stainless Steel
3	Upper Shaft	416 Stainless Steel	316 Stainless Steel (standard with 316 SS disc)
4	Lower Shaft	416 Stainless Steel	316 Stainless Steel (standard with 316 SS disc)
5	Seat	Buna-N or EPDM	Hypalon, Viton
6	Taper Pin	300 Series Stainless	No Option Available
7	O-Ring	Buna-N	No Option Available
8	Key	Carbon Steel	No Option Available
9	Bushing	TFE	Luberized Bronze
10	Bushing	TFE	Luberized Bronze
11	Thrust Washer	TFE	Luberized Bronze
12	End Plate	Ductile	No Option Available
13	O-Ring	Buna-N	No Option Available