

The Moniteur DSS Two Stage Package is a complete unit incorporating two solenoid valves and specially configured limit switches designed for two-stage operation. The package mounts to most rotary pneumatic actuators and allows users to transform an automated valve into a two stage shutoff package. The most common applications are:

- Filling or metering vessels. By being able to reduce the flow rate at a given point during a filling operation, it is possible to more accurately and efficiently fill a vessel.
- Flow dampening. With the two stage package, valves can be partially closed rapidly and then completely closed gradually. This dramatically reduces shock to pipes and valves and water hammer.

Requirements

- Two voltage sources to power both solenoid valves (#1 and #2).
- Contact logic, which may be provided by flow meters, scales, level sensors, or PLCs
- Spring return pneumatic actuator with a clean air source

Features

- Dual flow rate positions for filling vessels or flow dampening
- Fully adjustable set points allow the user flexibility to determine proper stage switching
- Open / Closed limit switches provide additional valve end point monitoring
- Factory assembled and tested, saving users and assemblers time and money

Ordering Information - packages for spring return actuators*

Nema Rating	Package Model No.	3-Way Solenoid (ASCO®)	2-way solenoid (ASCO®)	Solenoid Voltage	Solenoid Body Material
7,9	DSS-AMYB-11B1	EF8320G184	EF8262G93	120 VAC-60Hz	Brass
4,4x	DSS-FMYB-11B1	8320G184	8262G93	120 VAC-60Hz	Brass

* Custom packages to your specifications available on request

Standard Solenoid Valve Configuration**

3-Way Solenoid	Cv	Air Supply Port	Air to Actuator Port	To 2-way Exhaust Port	2-Way Solenoid	Cv	From 3-way Exhaust Port	Filter Exhaust Port
8320G184	0.12	2	1	3	8262G93	0.15	IN	OUT

** For larger actuators, solenoid valves with higher flow rates will be required. Contact Moniteur Devices with your requirements.

Wiring Diagram

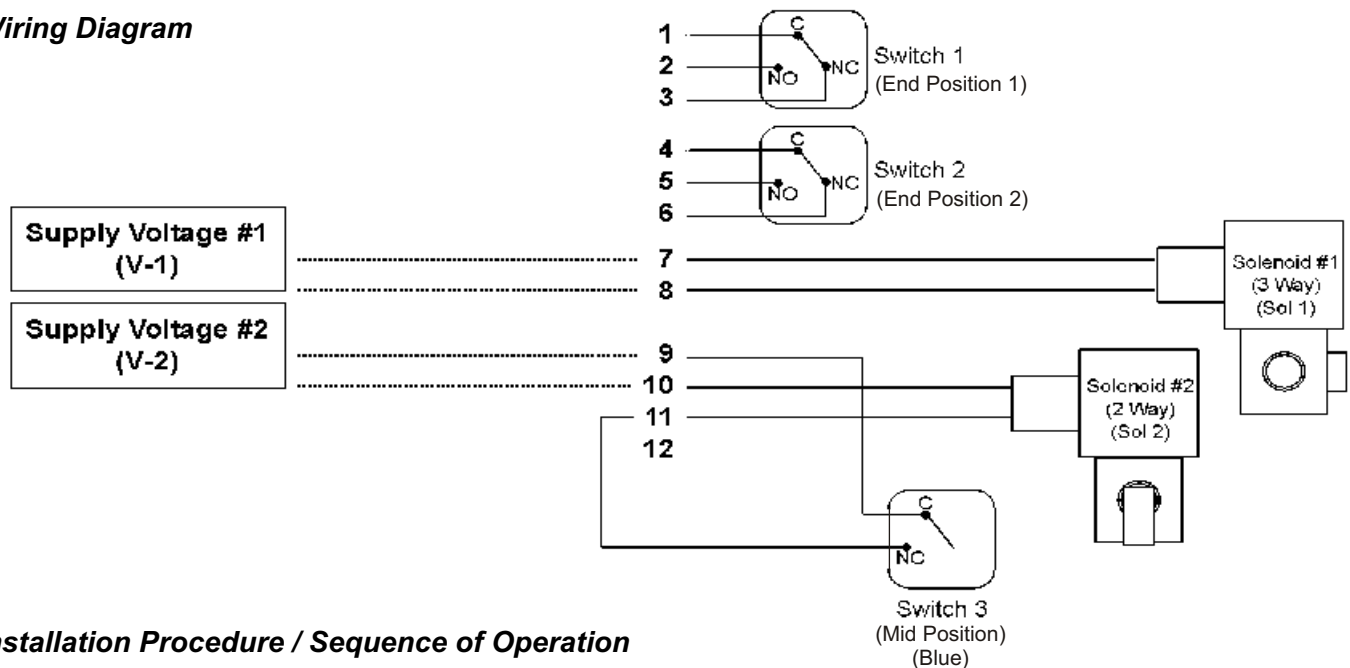

Installation Procedure / Sequence of Operation



Warning:

Be sure voltage and air pressure supplied match solenoid specifications.

1. Mount limit switch package to the rotary actuator with an appropriate mounting bracket.
2. Connect power and clean filtered air to proper positions (see table on other side for standard valves). Ensure that all air connections are tight and all electrical connections are secured at their proper terminal points.
3. With no power to V-1 and V-2, the valve should be in the fully closed position (sequence #1)
4. Energize V-1 and V-2 (sequence #2), solenoid #1 (sol1) will energize allowing the air pressure to rotate the valve/actuator package to the fully open position.
5. De-energize V-1 and the package will rotate in the opposite direction until the white cam trips switch 3 (blue) and energizes solenoid #2 (sol2). This will stop the valve rotation at the set mid position. If the mid position is incorrect, estimate approximately how many degrees of rotation the cam needs to be adjusted. CAUTION - do not adjust cam until the unit is in the fully closed position, as the unit might rotate unexpectedly if the cam is adjusted under power.
6. Finally, de-energize V-2 (both V-1 and V-2 will be de-energized) and solenoid #2 (sol2) will De-energize and the valve/actuator package will rotate to the fully closed position. One full cycle has just been completed. If the mid set position requires adjustment, adjust the package now.
7. Repeat steps 4-6 to verify adjustment and/or re-adjust dribble position.



Caution:

Do not adjust cams while cycling system as the unit might shift unexpectedly

Stage No.	Flow Condition Required	Supply Volt. 1 (V-1)	Supply Volt. 2 (V-2)	Solenoid #1 (Sol 1)	Solenoid #2 (Sol 2)
1	Shut off	De-energize	De-energize	De-energize	De-energize
2	Full Flow	Energize	Energize	Energize	De-energize*
3	Reduced Flow	De-energize	Energize	De-energize	Energize
4	Shut off	De-energize	De-energize	De-energize	De-energize

* Solenoid #2 is de-energized through the limit switch