

Penn Machine

Class 9000 Socketweld Reducing Inserts

For use with schedule 160 pipe

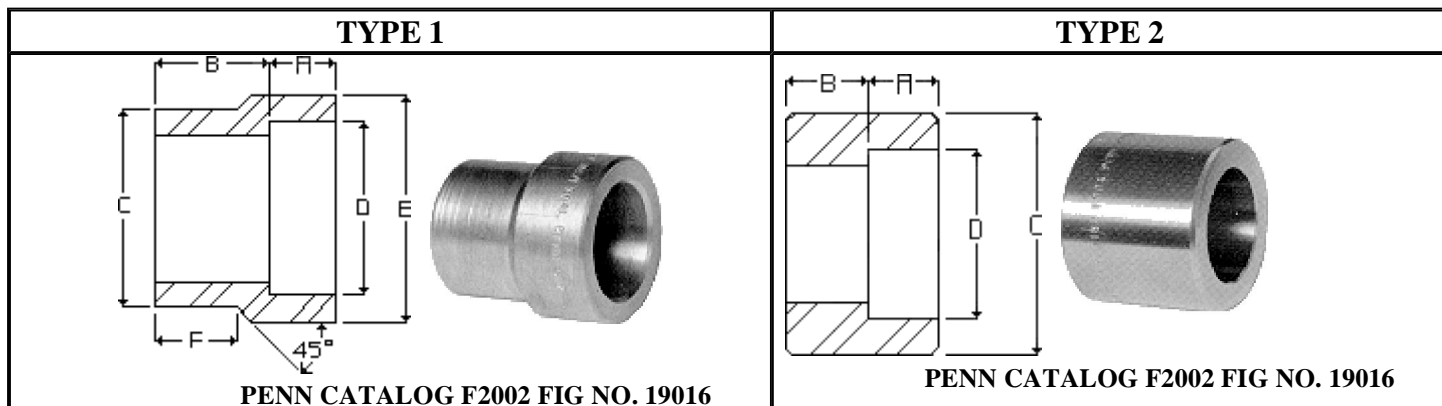

NOMINAL PIPE SIZE	DIA. C	DIA. D	INSERT TYPE	DIMENSIONS			
				A	B	E	F
2 X 1/2	2.375	.859	2	1/2	1-9/16	--	--
2-1/2 X 2	2.875	2.410	1	7/8	1-3/4	4-1/4	1-1/16
2-1/2 X 1-1/2	2.875	1.922	1	3/4	1-7/16	3-5/8	1-1/16
2-1/2 X 1-1/4	2.875	1.682	2	11/16	1-5/8	--	--
2-1/2 X 1	2.875	1.335	2	5/8	1-11/16	--	--
3 X 2-1/2	3.500	2.910	1	15/16	1-15/16	5	1-1/8
3 X 2	3.500	2.410	1	7/8	1-1/2	4-1/4	1-1/8
3 X 1-1/2	3.500	1.922	2	3/4	1-11/16	--	--
3 X 1-1/4	3.500	1.682	2	11/16	1-3/4	--	--
3 X 1	3.500	1.335	2	5/8	1-13/16	--	--
4 X 3	4.500	3.536	1	1	2	5-1/2	1-1/4
4 X 2-1/2	4.500	2.910	2	15/16	1-11/16	--	--
4 X 2	4.500	2.410	2	7/8	1-3/4	--	--
4 X 1-1/2	4.500	1.922	2	3/4	1-7/8	--	--
4 X 1-1/4	4.500	1.682	2	11/16	1-15/16	--	--
4 X 1	4.500	1.335	2	5/8	2	--	--

[Fitting catalog](#) | [Product catalog](#) | [Request quote/information](#) | [Home](#)

Web site created by Penn Machine. Send questions or comments to [James Friant](#).