

Stainless Steel Flanged Ball Valve



FL SS-100-150 FL SS-100-300

 125 PSIG



Stainless Steel
Flanged Ball Valve

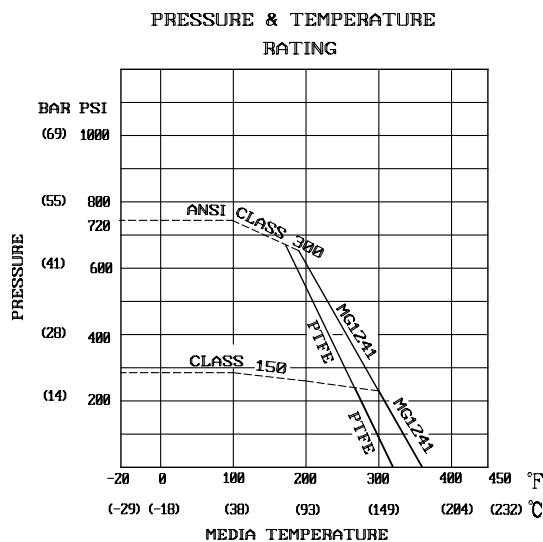

Description

1/4 turn, CF8M Stainless steel body, 316 Stainless steel ball and stem, 100% full port, blowout proof stem, 2-piece body design.

Features

- Full Port
- PTFE seats
- Wrench Operator
- Locking device
- Acuator mounting pad
- Gear operator standard on 10" - 12"
- Fire Safe Item 6:8 Graphite
- Air Tested - Seat Leakage: 6 kgf/cm²G
- Hydraulic Tested - Body: 30 kgf/cm²G

Approvals

- Flange: ANSI B16.5
- Face to Face: ANSI B16.10
- API 607 (fire tite)
- NACE 01-75 stainless steel Approved
- CSA Certified 125 PSIG on sizes 2" - 8"

Warranty

The Company, for a period of one year from the date of shipment, warrants each product or system of its own manufacture to the original purchaser to be free from defects in material and workmanship under normal use, service and maintenance.

WARNING

Do not lock valve handle in **OPEN** poistion on natural gas hazardous service.

Architect/Engineer approval

Job Name _____ Date _____
 Model Specified _____ Quantity _____
 Variations Specified _____
 Customer/Wholesaler _____
 Contractor _____
 Architect _____

Note: Information subject to change without notice.



Jomar International Ltd.
 7243 Miller Drive
 Warren, MI 48092
 Phone: 800-325-5690
 Fax: 800-628-4194
 www.jomar.com

Stainless Steel Flanged Ball Valve

FL SS-100-150 FL SS-100-300



Description

1/4 turn, CF8M Stainless steel body, 316 Stainless steel ball and stem, 100% full port, blowout proof stem, 2-piece body design.

Dimensions in Inches

Stainless Steel Flanged Ball Valve 150lb.

Computer No.	Valve SIZE	A	B	C	D	G	I	L	H	Bolts
600-108	2"	1.968	3.622	4.744	5.984	.626	.063	7.013	.75	4
600-110	3"	3.150	5	6.003	7.480	.752	.063	7.998	.75	4
600-111	4"	3.936	6.181	7.5	9.022	.941	.063	9.022	.75	8
*600-112	6"	5.989	7.322	9.515	10.992	1.000	.063	15.523	.88	8
*600-113	8"	7.988	10.638	11.760	13.514	1.122	.063	18.005	.88	8

*6"-8" SPECIAL ORDER

Stainless Steel Flanged Ball Valve 300lb.

Computer No.	Valve SIZE	A	B	C	D	G	I	L	H	Bolts
601-128	2"	1.968	3.624	5.003	6.501	.626	.063	7.007	.75	8
600-130	3"	3.152	5.003	6.619	8.274	.752	.063	7.992	.88	8
600-131	4"	3.936	6.185	7.880	10.007	.940	.063	9.015	.88	8
*600-132	6"	5.910	8.510	10.638	12.529	.941	.063	14.01	.88	12
*600-133	8"	7.880	10.638	13.002	15.011	1	.063	15.51	1.00	12

*6"-8" SPECIAL ORDER

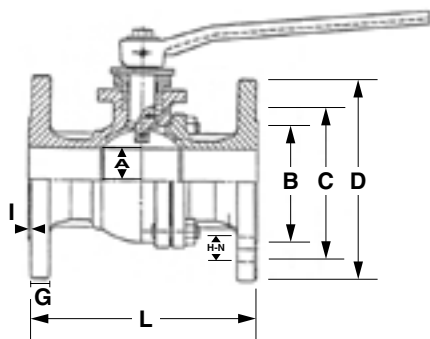

Material Specifications

No.	Part Name	Materials
1	Body	CF8M Stainless Steel
2	End Adapter	CF8M Stainless Steel
3	Seat (2)	PTFE + 15% G.F.
4	Ball	CF8M Stainless Steel
5	Stem	316 Stainless Steel
6	Joint Seal	PTFE/Graphite
7	Gasket	PTFE
8	Seal	PTFE/Graphite
9	Gland Bushing	PTFE
10	Gland Flange	CF8M Stainless Steel
11	Gland Bolts	304 Stainless Steel
12	Stopper	304 Stainless Steel
13	Snap Ring	Steel
14	Handle	Ductile Iron
15	Flat Washer	Steel
16	Handle Bolt	304 Stainless Steel
17	Body Bolt (4)	ASTM A193 B8
18	Handle Set Screw	Steel
19	Static Device	304 Stainless Steel
20	Spring	304 Stainless Steel

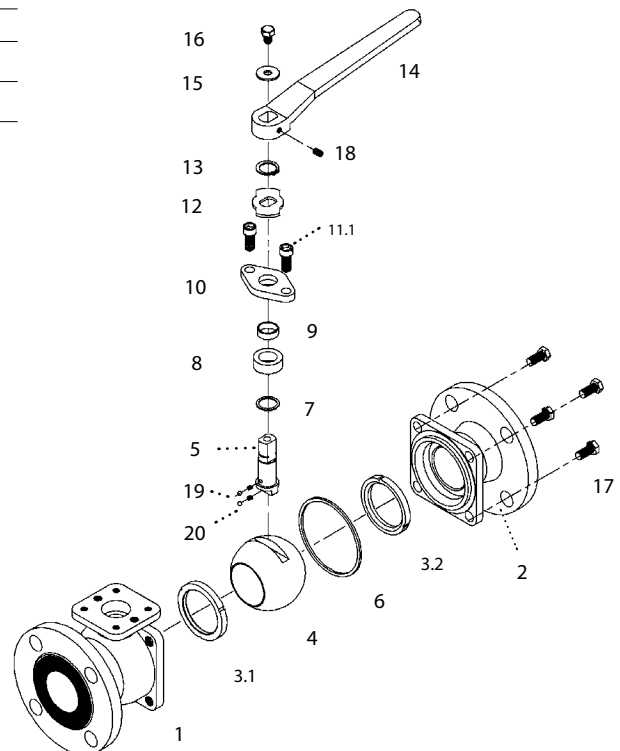

Note: Information subject to change without notice.



Jomar International Ltd.
7243 Miller Drive
Warren, MI 48092
Phone: 800-325-5690
Fax: 800-628-4194
www.jomar.com

© Copyright 2006 Printed in U.S.A.
FL-SS-100-150/300
04/06