

Resilient Seated Butterfly Valves: 2"-12"

Sanitary & Chemical Applications, Wafer & Lug Bodies

399
SERIES
392



ultraflo®

399/392 SERIES

Ultraflo proudly offers the 399/392 Series sanitary/chemical butterfly valve. The 399/392 Series provides a bi-directional pressure rating of **150 psi** with stainless steel disc/stems and **100 psi** with encapsulated disc/stems. Undercut disc/stems, rated for **50 psi** and requiring less operating torque, are also available. The 399/392 Series has been designed for applications requiring high flow, minimal product entrapment and complete protection of valve components from the line media. Valve sizes are from **2"–12"**.

399 valves are **Wafer** style bodies offered in **Stainless Steel, Cast Iron** and **Aluminum**. 392 valves are **Lug** style bodies offered in **Stainless Steel** and **Nodular Iron**.

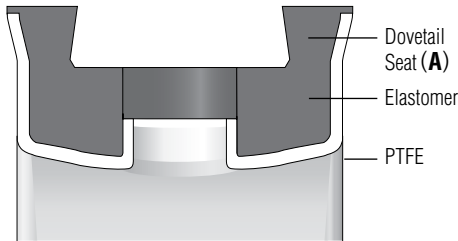

PTFE encapsulated seat. Section view at stem hole.

Ultraflo's resilient **Seat (A)** is the heart of all 300 Series valves. The seat incorporates a dovetail retention system ensuring positive alignment and ease of assembly. The PTFE liner, as shown above, is isostatically molded to extend up through the stem hole, completely isolating the elastomer backing from the line media in the event of primary seal failure. All 300 Series seats include a flange seal molded into the seat face providing a positive seal with all popular flanges. Valves installed in dead end service (downstream flange removed) are derated to 75 psi for 2"–12" valves, 50 psi for 14"–24" valves.

Features Primary and Secondary Seals (B) The primary seal is formed by an interference fit between the disc hub and the seat flat. The secondary seal is an interference fit between the stem and seat stem hole. These seals prevent line media from coming into contact with other valve components. Ultraflo's ultrathin one-piece **Disc/Stem (C)** provides a high flow capacity with smooth flow characteristics that greatly reduce line media pressure drops. The disc edge is CNC machined and hand polished to produce bubble tight shut off, minimum torque and longer seat life. The **Upper Stem Bushing (D)** absorbs operator side thrusts, provides precision alignment to ensure less wear and lowers operating torque. The **Lower Stem Bushing (E)** eliminates gaulding and frozen stems. Both upper and lower bushings are heavy duty non-corrosive thermoplastic polymer. A **Stem Packing (F)** prevents external contaminants from entering the stem bore. The **Split Body (G)** design simplifies field maintenance by eliminating the need for special tools or presses during installation of replacement seats. All 300 Series valve bodies are designed to fit between ASME/ANSI 125 or 150 lb. flanges. **Body Recesses (H)** accommodate lightweight flanges. **Body Bolt (I)** materials are zinc plated carbon steel or stainless steel as standard.

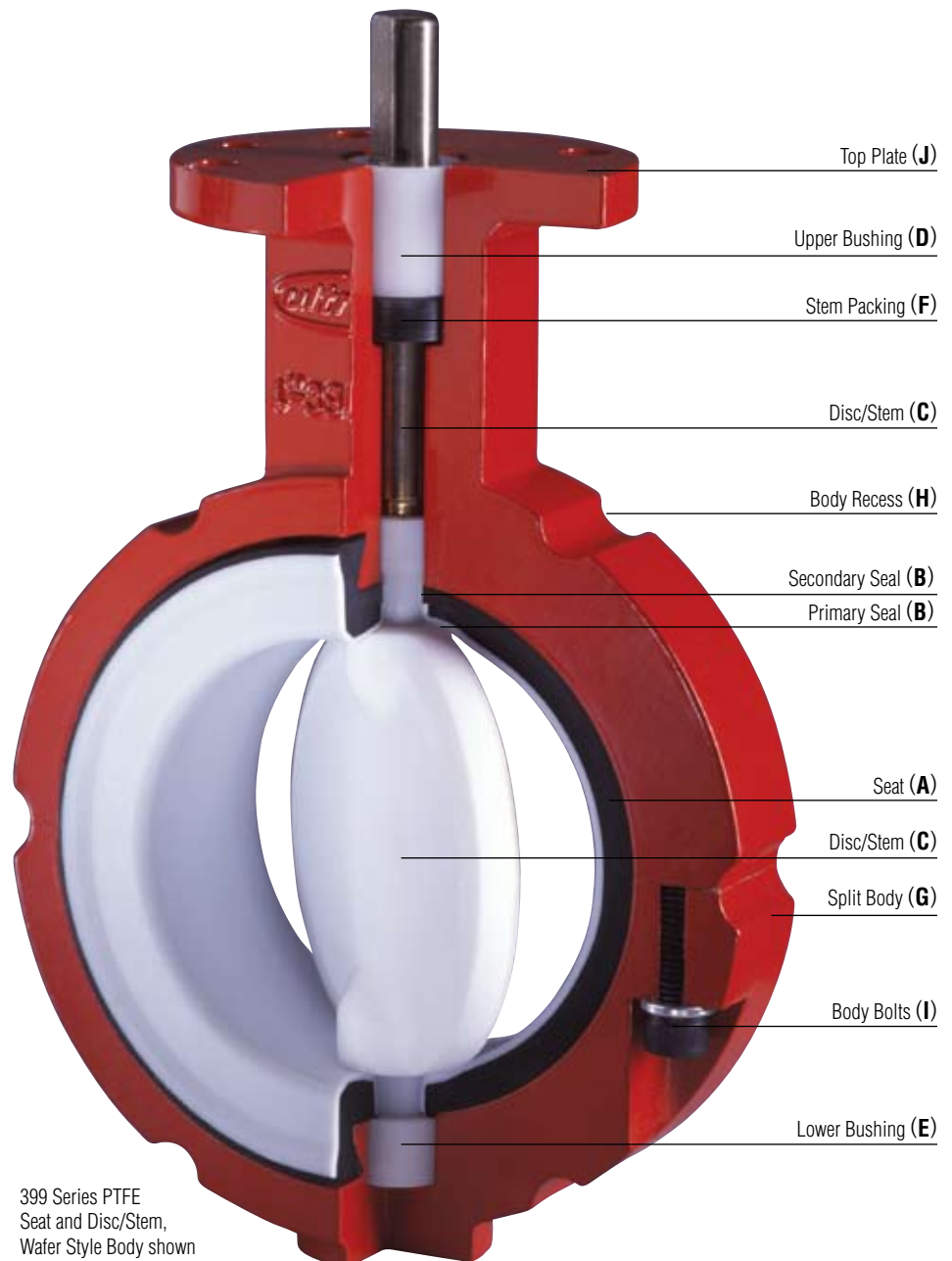

399 Series PTFE Seat and Disc/Stem, Wafer Style Body shown

399/392 SERIES

Ideal for Sanitary, Chemical and Corrosive Applications

The 300 Series is one of the true sanitary butterfly valves on the market today. The two-piece split body allows for a one-piece investment cast disc/stem with a smooth finish free of porosity, voids or cracks. This design provides complete protection from particle entrapment. A variety of coatings are available for chemical and abrasive service as well as sanitary applications.

All sizes of Cast Iron, Nodular Iron and Aluminum bodies and 8"-12" Stainless Steel bodies have a CNC machined **Top Plate (J)** with standardized drilling for total actuator and operator interchangeability. A handle notch plate is supplied with the manual handle kit.

2"-6" Stainless Steel valve bodies feature an integrally cast **Throttling Top Plate** with a self draining recess ensuring complete drainage of wash-down media.



For high corrosive and sanitary applications, discs/stems are offered in high polish or satin finish 316 Stainless Steel, PTFE encapsulated and a variety of other coatings. Bodies are offered in investment cast 316 Stainless Steel for these demanding applications.

Seats are available as standard in PTFE, Nitrile, EPDM, Buna and FKM. All compounds other than FKM are FDA approved.

All Ultraflo valves are tested to 110% of pressure rating for bubble tight shut off before shipment.

All 399/392 Series valves are designed to meet MSS SP67 dimensional standards.

Components

Item	Description	Qty.
1	Split Body	1
2	Seat	1
3	Disc	1
4	Upper Bushing	1
5	Stem Packing	1
6	Lower Bushing	1
7	Body Bolt	2
8	Lock Washer	2

Materials of Construction

Bodies: Cast Iron, Nodular Iron and Investment Cast 316 Stainless Steel in both wafer and lug style split bodies. Aluminum bodies are available in wafer only.

Seats: PTFE, EPDM, Nitrile, Buna, FKM. Nitrile and EPDM seats are available in FDA food grade white.

Disc/Stems: 17-4 Stainless Steel and Investment Cast 316 Stainless Steel, available with satin or high polish finish. PTFE encapsulated and other custom disc coatings are available.

Upper and Lower Bushings:

Thermoplastic Polymer

Stem Packing:

Buna-N

Body Bolts and Lock Washers:

Zinc Plated Carbon Steel or Stainless Steel

399 Series Cast Iron Wafer Style Body

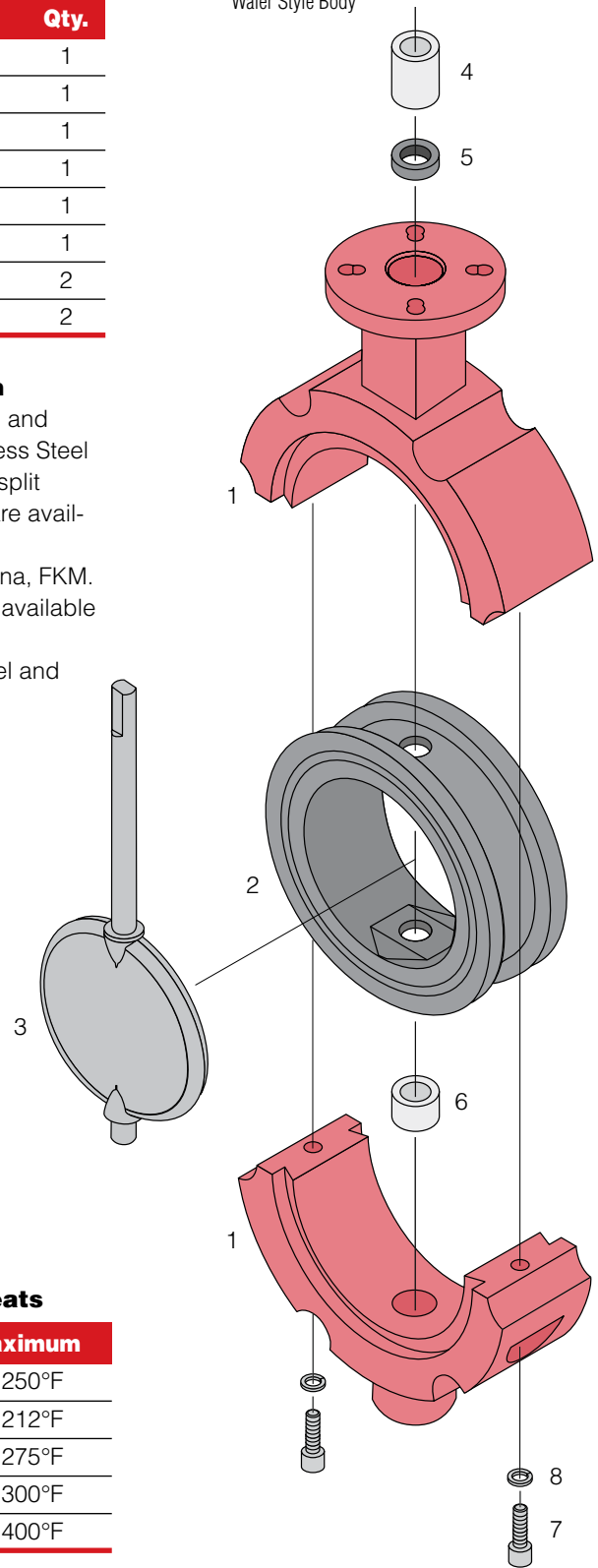

Temperature Range of Seats

Type	Minimum	Maximum
EPDM	-40°F	+250°F
Buna	0°F	+212°F
Nitrile	-20°F	+275°F
PTFE	-20°F	+300°F
FKM	0°F	+400°F

399/392 SERIES

Dimensions

Valve Size ins	mm	A	B	C	D	E	F	G	H	Q	R	S	T	U	Lug Data	
		BC	Tap													
2	50	4.00	.375	.563	1.250	4.063	4.125	2.00	1.625	1.313	3.250	.438	2.760	.375	4.750	.625-11
3	75	4.00	.375	.563	1.250	5.00	5.375	3.00	1.750	2.563	3.250	.438	2.760	.375	6.00	.625-11
4	100	4.00	.438	.625	1.250	6.00	6.875	4.00	2.00	3.563	3.250	.438	2.760	.375	7.50	.625-11
5	125	4.00	.438	.625	1.250	6.00	7.750	5.00	2.125	4.531	3.250	.438	2.760	.375	8.50	.750-10
6	150	4.00	.500	.750	1.250	6.625	8.750	5.750	2.125	5.438	3.250	.438	2.760	.375	9.50	.750-10
8	200	6.00	.625	.875	1.250	8.313	11.00	7.750	2.50	7.438	5.00	.563	4.020	.438	11.750	.750-10
10	250	6.00	—	1.125*	2.00	9.125	13.375	9.750	2.50	9.531	5.00	.563	4.020	.438	14.250	.875-9
12	300	6.00	—	1.125*	2.00	10.645	16.125	11.750	3.00	11.50	5.00	.563	4.020	.438	17.00	.875-9

All 399/392 Series are designed to meet MSS SP67 dimensional standards.

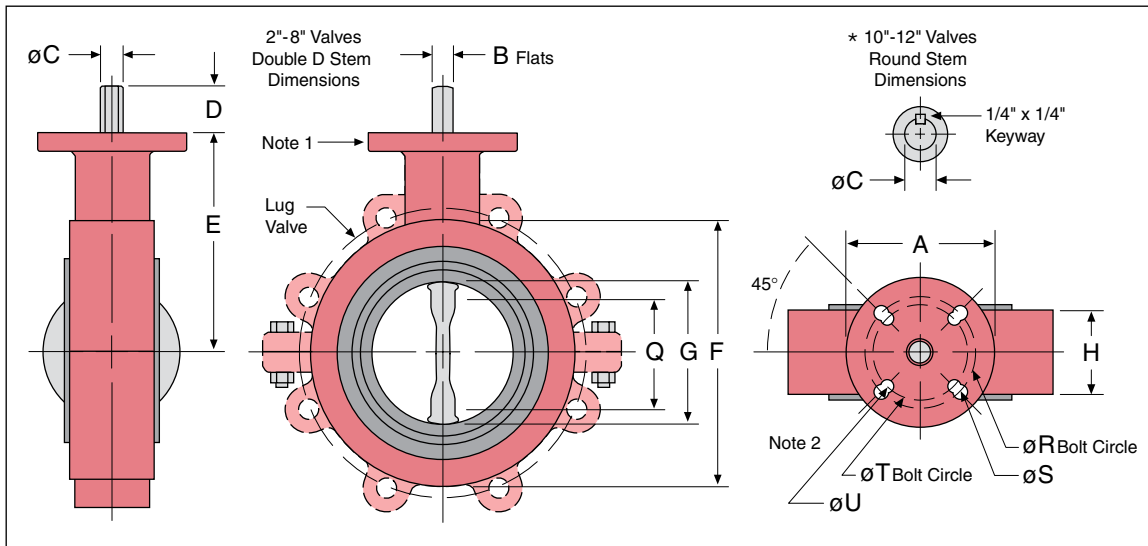

Notes:

- 2" - 6" Stainless Steel Valve Bodies have an integral Throttling Top Plate. 8", 10" and 12" SS Valves, and all sizes Cast Iron, Nodular Iron & Aluminum Valves have standard Top Flanges, notch plates are supplied with handle.
- Bolt Circle T and Hole Diameter U meet ISO 5211 standards for Top Flange Drilling: 2" - 6" = F7 8" - 12" = F12 Not applicable to Aluminum bodies.



Operator and Actuator Mounting

Ultraflo has designed the 300 Series operator mounting Top Flange to ISO 5211 specifications for direct mounting of manual operators and actuators. Designed to recognized industrial standards, the Double D stem connection provides a secure connection with most actuators eliminating the need for brackets.

Ultraflo offers a wide range of automation products including handles, gear operators, rack and pinion pneumatic actuators, pneumatic cylinder and wrench arm assemblies, electric actuators, pneumatic and electro-pneumatic positioners, solenoids, valve position indicators, proximity and limit switches.

Flange Requirements

The valve O.D. and flange bolt circle must share a common center line. The valve is designed to be placed between ASME/ANSI 125 or 150 lb. flanges.

The data represented in this brochure is for general information only. Manufacturer is not responsible for acceptability of these products in relation to system requirements. Consult your Ultraflo representative for specific performance data and proper materials selection for your particular application.



Ultraflo Corporation

A Subsidiary of Bray International, Inc.

8 Trautman Industrial Drive
Ste. Genevieve MO 63670
800.950.1762 Fax 573.883.8882
www.ultraflovalve.com