

TECHNICAL SPECIFICATIONS

Full-Face Wafer/Lug Butterfly Valves: 2"– 16"
Series 710 Lined Fiberglass Composite



1. SCOPE

Full-Face Wafer/Lug Butterfly Valves with through-drilled or threaded flange bolt holes for corrosive and/or abrasive chemical services.

2. SERVICE RATING

Continuous temperature service from -50 to 275° F. Short-term exposures to 300° F are acceptable.

150 PSI PTFE/PFA rating for complete temperature range.

3. MATERIALS OF CONSTRUCTION

- (1) **Body:** Glass fiber reinforced vinyl ester resin
- (2) **Disc:** PFA-lined, UHMWPE-lined, 316 stainless steel, Gr. C-2 Titanium
- (3) **Seat:** PTFE/silicone, PTFE/Viton, UHMWPE/silicone
- (4) **Body Bolts:** PTFE-coated ASTM A193 Gr. B7
- (5) **Flange Connections:** Bolt holes may be through drilled (wafer) or threaded (lug).
- (6) **Actuator Mounting Pad:** Per ISO 5211

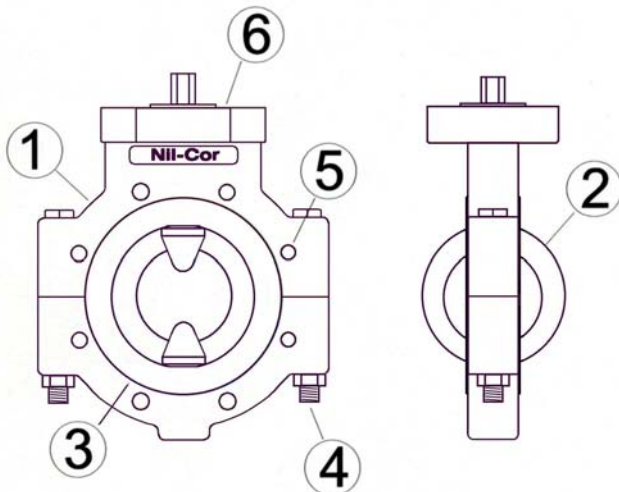

4. DESIGN

- Body shall have flange clearance holes per ANSI B16.5 CL 150 for alignment or be threaded. Threaded valves are fully rated for end-of-line service.
- Body shall have burst pressure at least 4x the rated pressure, per ASTM 1173.
- Face-to-face dimensions per MSS SP67 as listed on Page 2.
- Disc shall be a one piece blowout proof design.
- Stem sealing to be provided by mating primary seat/disc spherical surfaces backed up by tortuous locking barbs
- Valve design shall be such that it can be bolted into a standard PTFE-lined steel pipe and the valve disc not interfere with the lining of the pipe.
- Valve disc/seat to provide bubble tight shut off per API 598 and MSS SP61.
- Gear or lever handle shall be available on all sizes.
- Valves shall be capable of on-off actuation or modulating control with pneumatic, electric or hydraulic actuators.

5. QUALITY ASSURANCE

- The Manufacturer's facility shall be certified to ISO 9001 or equivalent.
- Each valve shall be pneumatically tested to 165 psi with no evidence of external leakage.
- Each valve shall be subjected to a pneumatic seat test at 150 psi with no allowable leakage.

6. PACKING AND SHIPPING

Valves shall be shipped in the closed position. Each valve shall be marked with the manufacturer, size, series, construction materials, serial number, and valve component designation in accordance with MSS SP25.

7. AVAILABILITY

Valves meeting this specification are available from:

Nil-Cor®, LLC
4855 Broadmoor Ave.
Kentwood, MI 49512
P: 616-554-3100
F: 616-554-5623
www.nilcor.com

DIMENSIONS

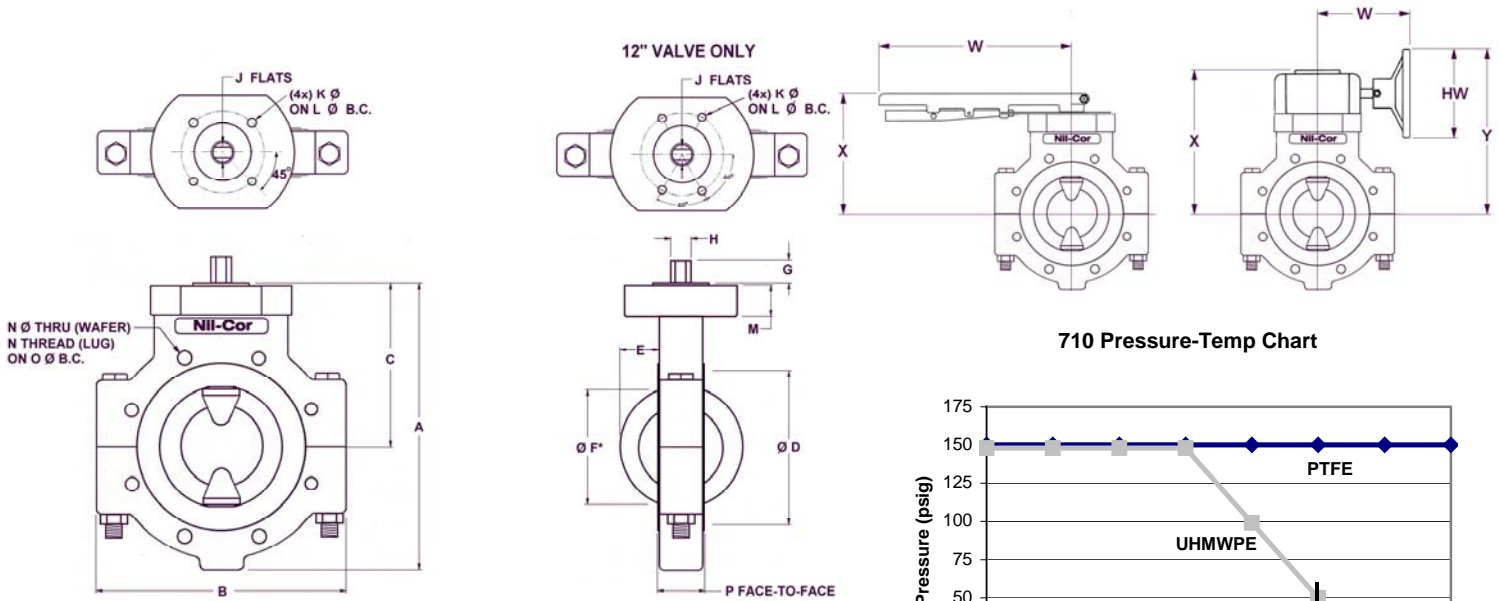

710 Pressure-Temp Chart

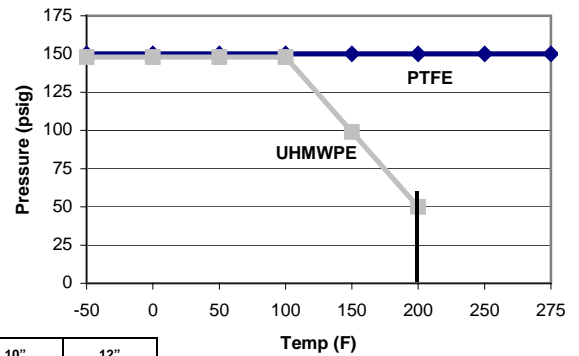

SIZE:	2"	3"	4"	6"	8"	10"	12"
Flow Coefficient Cv	104	350	553	1,460	3,077	5,263	7,897
Break Torque, in-lbs / (NM) PTFE LINER	270 / (31)	330 / (37)	550 / (62)	1275 / (144)	1640 / (185)	3300 / (373)	4145 / (468)
Break Torque, in-lbs / (NM) UHMWPE LINER	400 / (45)	470 / (53)	750 / (85)	3680 / (416)	4090 / (462)	6930 / (783)	8070 / (912)

ENGLISH UNITS (Dimensions in inches)

SIZE	SHAFT																ISO FLANGE		WAFER	LUG	LEVER				GEAR				WT (LBS)
	A	B	C	D	E	F	G	H	J	K	L	M	N	N	O	P	W	X	W	X	Y	HW							
2	8.78	8.25	5.53	3.61	0.47	2.06	1.31	0.625	0.439	0.44	4.016	0.50	0.75	5/8 - 11	4.75	1.69	13.75	6.87	6.25	8.11	9.64	6.00	6						
3	10.06	9.00	6.31	5.00	0.69	2.59	1.31	0.625	0.439	0.44	4.016	0.88	0.75	5/8 - 11	6.00	1.81	13.75	7.65	6.25	8.89	10.42	6.00	9						
4	11.31	10.25	6.81	6.00	1.00	3.47	1.31	0.625	0.439	0.44	4.016	0.88	0.75	5/8 - 11	7.50	2.06	13.75	8.15	6.25	9.39	10.92	6.00	14						
6	14.09	12.22	8.06	8.25	1.88	5.50	1.31	1.000	0.836	0.44	4.016	1.50	0.88	3/4 - 10	9.50	2.22	13.75	9.40	6.75	10.64	13.17	8.00	25						
8	17.19	15.39	8.44	10.25	2.69	7.38	1.31	1.000	0.836	0.44	4.016	1.50	0.88	3/4 - 10	11.75	2.38	NA	NA	6.75	11.02	13.55	8.00	34						
10	21.09	18.81	12.31	12.25	3.63	9.56	1.75	1.375	1.000	0.56	4.921	1.50	1.00	7/8 - 9	14.25	2.69	NA	NA	7.25	15.29	19.69	12.00	52						
12	23.75	21.00	13.31	14.38	4.44	11.56	2.13	1.375	1.000	0.56**	4.921	1.50	1.00	7/8 - 9	17.00	3.09	NA	NA	7.25	16.29	20.69	12.00	65						

METRIC UNITS (Dimensions in mm)

SIZE	SHAFT																ISO FLANGE		WAFER	LUG	LEVER				GEAR				WT (KG)
	A	B	C	D	E	F	G	H	J	K	L	M	N	N	O	P	W	X	W	X	Y	HW							
50	223.0	209.6	140.5	91.7	11.9	52.3	33.3	15.88	11.15	11.2	102	12.7	19.1	5/8 - 11	120.7	42.9	349	174	159	206	245	152	2.7						
80	255.6	228.6	160.3	127.0	17.5	65.8	33.3	15.88	11.15	11.2	102	22.4	19.1	5/8 - 11	152.4	46.0	349	194	159	226	265	152	4.1						
100	287.3	260.4	173.0	152.4	25.4	88.1	33.3	15.88	11.15	11.2	102	22.4	19.1	5/8 - 11	190.5	52.4	349	207	159	238	277	152	6.4						
150	357.9	310.4	204.7	209.6	47.8	139.7	33.3	25.40	21.23	11.2	102	38.1	2.2	3/4 - 10	241.3	56.4	349	239	171	270	334	203	11.4						
200	436.6	390.9	214.4	260.4	68.3	187.5	33.3	25.40	21.23	11.2	102	38.1	22.4	3/4 - 10	298.5	60.3	NA	NA	171	280	344	203	15.5						
250	535.8	477.8	312.7	311.2	92.2	242.8	44.5	34.93	25.40	14.2	125	38.1	25.4	7/8 - 9	362.0	68.3	NA	NA	184	388	500	305	23.6						
300	603.3	533.4	338.1	365.3	112.8	293.6	54.1	34.93	25.40	14.2**	125	38.1	25.4	7/8 - 9	431.8	78.6	NA	NA	184	414	525	305	29.5						

NOTES:

*Lined piping which exceeds the liner thickness specification of ASTM F1545 may require spacers to avoid disc interference.
 ** 12" valve size only, the actuator mounting holes are offset 15° on ISO 5211 F12 bolt circle. (See Above)