

**Maximum Pipe Size:**  
6" Inside diameter  
7.25" Outside diameter

## Specification and Data Sheet **MODEL NO. 6-H**

1. **Product Name:** PILLOW BLOCK PIPESTAND MODEL NO. 6-H **NOTE:** Pillowblock pipestands are given model numbers which correspond to usual or nominal pipe names. Pipe that is called "six-inch" or 6" pipe has a 6" inside diameter and a larger outside diameter. Model 6-H will hold up to all usual and customary 6" and smaller pipe sizes, referring to the inside diameter. The maximum outside dimension of the pipe or conduit the model 6-H will hold is 7.25" diameter.
2. **Design Emphasis:** The Model 6-H has been designed specifically for 4", 5", and 6" gas piping and especially for chilled water and return drain piping of the same size. The versatility of the design for this product enables it to expand to hold any number of pipe running along the roof for maximum efficiency and cost savings to customers, contractors, and owners. Thus, this pipehanger product can be used to hold ganged piping 2, 3, 4 or more across and at varying heights above the roof. See below.
3. **Manufacturer:** MIRO INDUSTRIES, INC., 2700 South 900 West, Salt Lake City, Utah 84119  
Phone (800) 768-6978  
Fax (800) 440-7958
4. **Product Description:** A "roller-bearing" or "clevis hanger" pipe support hanger used to support roof mounted gas pipes, HVAC piping, electrical conduit, solar piping and other mechanical piping. Unique design absorbs thermal expansion and contraction of pipes thus preventing damage to the roof membrane. Pipes rest on a polycarbonate or steel roller or clevis hanger. The pipe support base is made of stainless steel polycarbonate or is hot-dip galvanized and all other metal parts are hot-dip galvanized steel. Pipestand will accommodate up to a 6" inside diameter pipe or up to 7.25" outside diameter pipes.
5. **Product Performance:** The roller or clevis hanger system serves to keep the pipestand hanger system directly over and beneath the pipe without binding and allows for some lateral expansion of the piping system. The base is gently rounded to prevent gouging the roof membrane.
6. **Compatibility:** Pillow Block Pipestands are recommended for use on and compatible with all current types of decking and with all commonly used built-up and single-ply roofing membranes where roof-mounted pipes occur. With heavier loads it is prudent to use a MIRO Support Pad or other traffic pad to further protect the roof membrane.
7. **Load Weight:** Maximum load weight not to exceed 300 lbs. per pipestand or 150 lbs. on each base.
8. **Composition and Materials:** The pipestand consists of three major components: (1) Two roof deck bases of stainless steel, polycarbonate or hot-dip galvanized steel which set upon the roof membrane, (2) A braced strut assembly of hot-dip galvanized steel which is supported by, rests upon, and is connected to the two bases, and (3) a hanger system supported by the strut consisting of a stainless steel all-thread rod which suspends a clevis hanger or a steel or polycarbonate resin roller system all suspended from the strut assembly.
9. **Size:** The Pillow Block Pipestand Model 6-H is made as follows: Each of the two deck bases are 8" by 14" (SS or HDG) or 9" by 15.25" (P), has a cradle width which allows at least 12" between the strut assembly, and can be built to adjust in height to support pipe from a low of 2" to a custom height. The strut is 1-5/8" by 13/16", the strut assembly is constructed at various heights to give pipe clearance adjustment above the roof.
10. **Adjustable Height:** The model 6-H and its related configurations allow adjustable height as desired or required by the code or roof system. Cross-bracing two pipestands every 3<sup>rd</sup> or 4<sup>th</sup> pipestand is recommended and required for elevations 36" and higher. Purchasers should specify desired heights upon quote requests and ordering of the pillowblock hangers.
11. **Installation Process:** (1) Center the pipestand beneath the pipe so that the cradle allows the pipe to be squarely over and through the roller structure or clevis hanger of the pipestand. (2) Adjust the pipestand to the desired height and to even load with other pipestands. Make certain the horizontal support strut is level. (3) Set the pipe in the clevis hanger without dropping or causing undue impact. If desired, an additional sheet of roofing material, a MIRO Deck Plate, or MIRO Support Pad can be installed beneath the pipestand. For built up roofs, all loose aggregate from an area 20" square should be removed from the area directly beneath the pipestand and then follow the installation directions set forth above. Care should be taken to install each pipestand so it supports a proportional and equal amount of weight at each pipestand.  
  
OPTIONAL METHOD OF INSTALLATION (Not Recommended): Where code requires or as desired, the pipestands may be attached to the roof structure by appropriate and compatible rooftop fasteners through holes then drilled in the bases pitchpan at the time of installation.
12. **Spacing:** Manufacturer's recommended spacing is not to exceed 10 foot centers depending upon the load. Do not exceed 300 lbs. load weight (150 lbs. on each base) and make certain each pipestand is adjusted in height to even load at all pipestands.
13. **Availability:** Pillow Block Pipestands are marketed throughout the United States through representatives and distributors.
14. **Maintenance:** Normally maintenance is not required. Semi-annual inspection is required to check pipestand position and set pipe alignment, weight distribution and improper installation which may cause pipestand damage or failure.
15. **Installation and Technical Services:** Please call MIRO INDUSTRIES, INC.: (800) 768-6978.  
[www.miroind.com](http://www.miroind.com) for technical information and for graphic and for CAD drawing downloads.

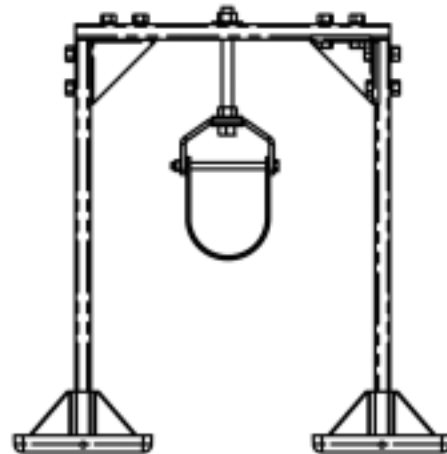
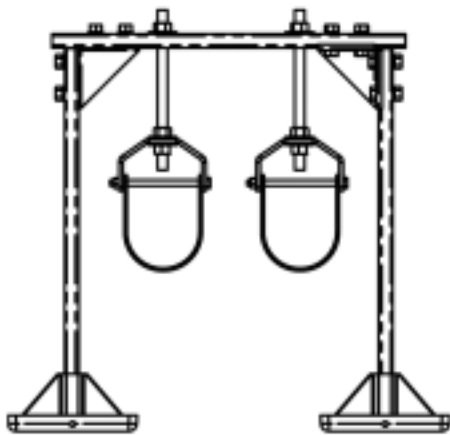
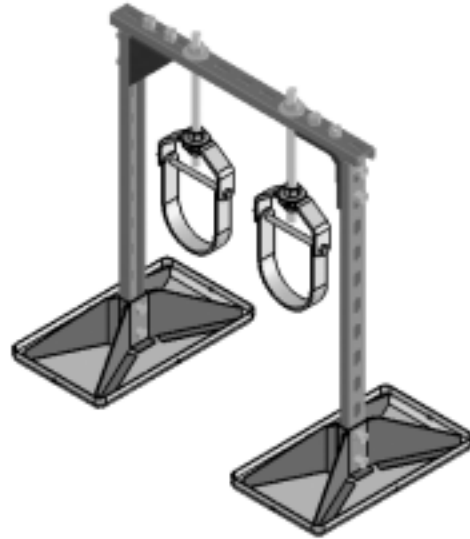
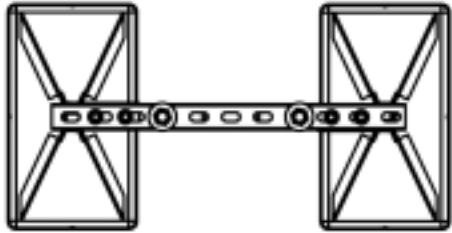

This document, attachments, and all of the information therein are the property of MIRO Industries, Inc. The information contained is loaned, subject to return upon demand, and is not to be used directly or indirectly in any way detrimental to our interest. Further, the information contained therein shall not be used, in whole or in part, except when allowed by written authorization from MIRO Industries, Inc.

Copyright MIRO Industries, Inc. 2003.

**6-H HDG and SS**

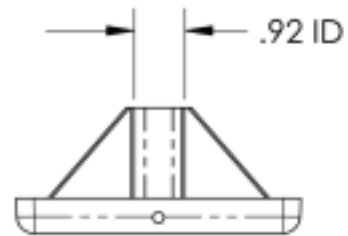
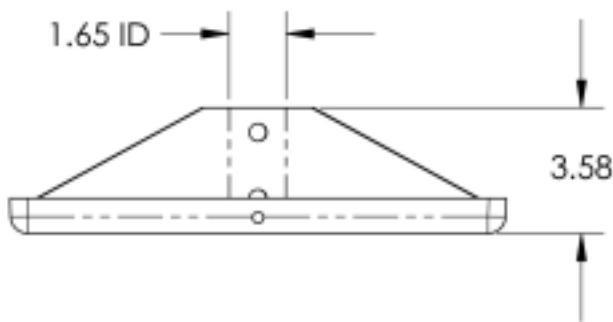
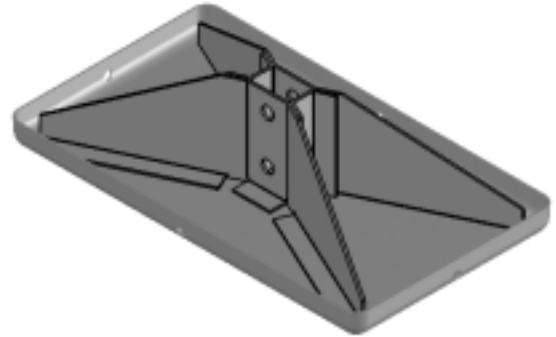
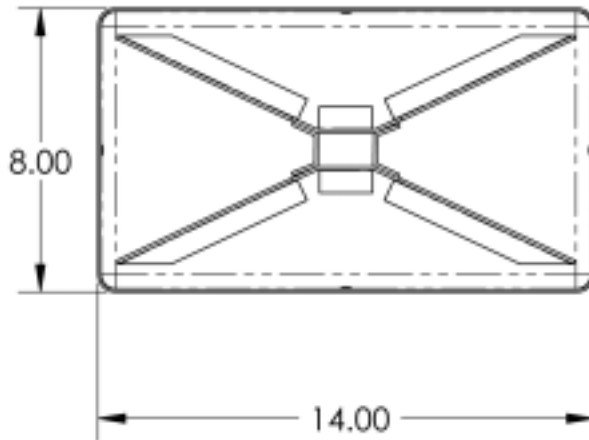

- **LOAD** — Not to exceed 150 lbs./base.
- **MATERIAL** — Base is made of hot dip galvanized or stainless steel.
- **WEIGHT** — Each base weighs 4-1/2 lbs.
- **MIRO warranty** is not applicable to this base.

The warranty for MIRO products is only for complete pipe support systems manufactured by MIRO Industries. The warranty does not cover the sale of this base only.

This document, attachments, and all of the information therein are the property of MIRO Industries, Inc. The information contained is loaned, subject to return upon demand, and is not to be used directly or indirectly in any way detrimental to our interest. Further, the information contained therein shall not be used, in whole or in part, except when allowed by written authorization from MIRO Industries, Inc.

Copyright MIRO Industries, Inc. 2003.

## 6-H Base HDG and SS

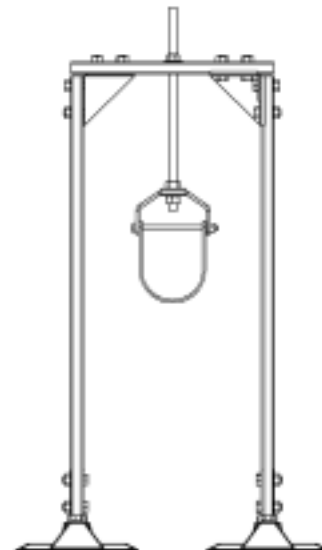
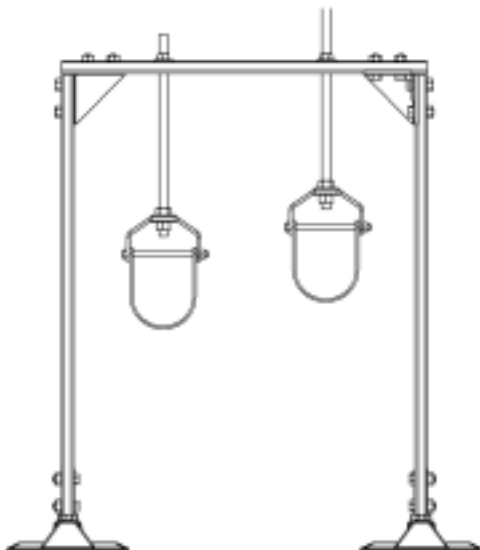
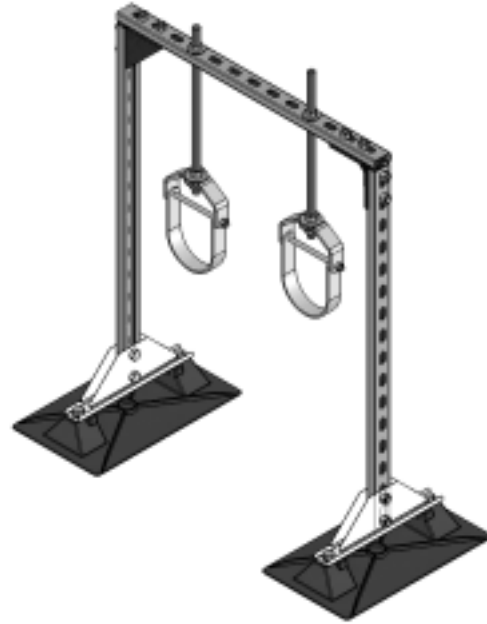

This document, attachments, and all of the information therein are the property of MIRO Industries, Inc. The information contained is loaned, subject to return upon demand, and is not to be used directly or indirectly in any way detrimental to our interest. Further, the information contained therein shall not be used, in whole or in part, except when allowed by written authorization from MIRO Industries, Inc.

Copyright MIRO Industries, Inc. 2003.

**6-H P**

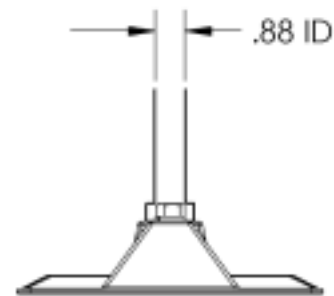
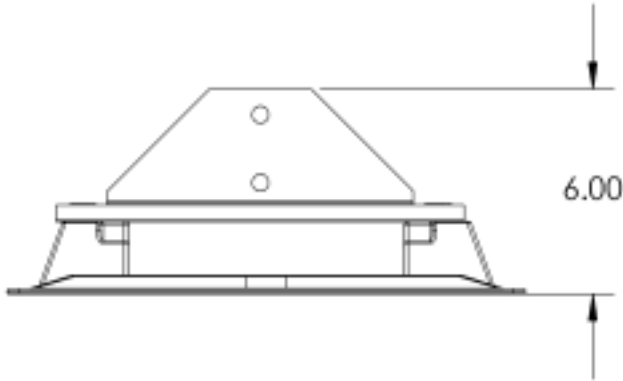
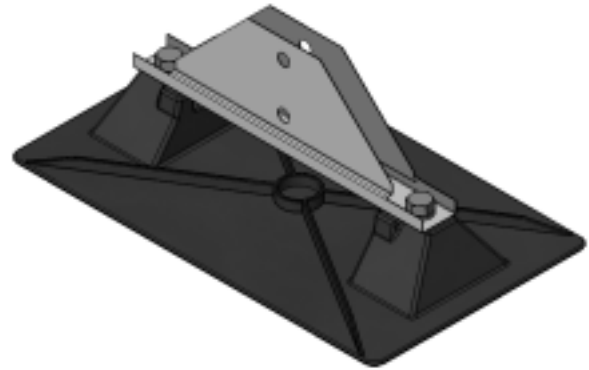
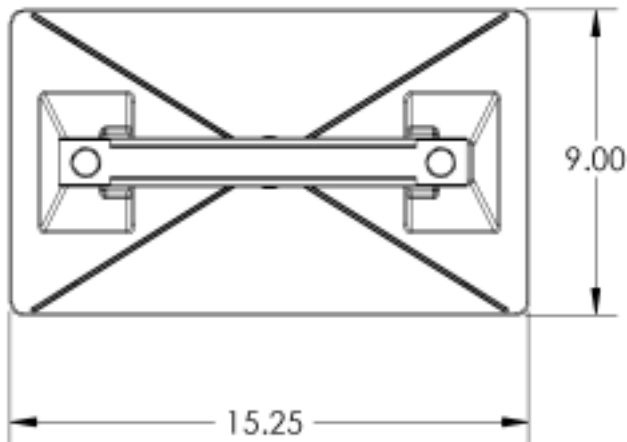

- **LOAD** — Not to exceed 150 lbs./base.
- **MATERIAL** — Base is made of polycarbonate plastic and components are hot dip galvanized steel.
- **WEIGHT** — Each base weighs 2-1/2 lbs.
- **MIRO warranty** is not applicable to this base.

The warranty for MIRO products is only for complete pipe support systems manufactured by MIRO Industries. The warranty does not cover the sale of this base only.

This document, attachments, and all of the information therein are the property of MIRO Industries, Inc. The information contained is loaned, subject to return upon demand, and is not to be used directly or indirectly in any way detrimental to our interest. Further, the information contained therein shall not be used, in whole or in part, except when allowed by written authorization from MIRO Industries, Inc.

Copyright MIRO Industries, Inc. 2003.

## 6-H Base P