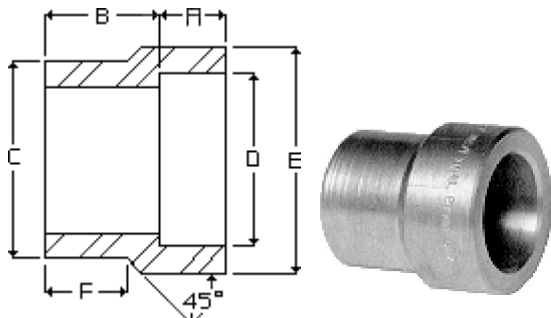

# Penn Machine

## Class 6000 Reducing Inserts

### MSS-SP-79-1999

For use with schedule 160 pipe

							
TYPE 1      PENN CATALOG F2002 FIG NO. 16016				TYPE 2      PENN CATALOG F2002 FIG NO. 16016			
NOMINAL PIPE SIZE	DIA. C	DIA. D	INSERT TYPE	DIMENSIONS			
				A	B	E	F
1/4 X 1/8	.540	.426	1	7/16	13/16	7/8	5/8
3/8 X 1/4	.675	.560	1	7/16	13/16	1-1/16	5/8
3/8 X 1/8	.675	.426	1	7/16	13/16	7/8	5/8
1/2 X 3/8	.840	.693	1	7/16	7/8	1-5/16	5/8
1/2 X 1/4	.840	.560	1	7/16	13/16	1	5/8
1/2 X 1/8	.840	.426	1	7/16	13/16	7/8	5/8
3/4 X 1/2	1.050	.859	1	1/2	1	1-1/2	3/4
3/4 X 3/8	1.050	.693	1	7/16	7/8	1-5/16	3/4
3/4 X 1/4	1.050	.560	2	7/16	7/8	--	--
3/4 X 1/8	1.050	.426	2	7/16	7/8	--	--
1 X 3/4	1.315	1.071	1	9/16	1-1/8	1-3/4	13/16
1 X 1/2	1.315	.859	1	1/2	1-1/8	1-1/2	13/16
1 X 3/8	1.315	.693	2	7/16	7/8	--	--
1 X 1/4	1.315	.560	2	7/16	15/16	--	--
1-1/4 X 1	1.660	1.335	1	5/8	1-3/16	2-1/4	7/8
1-1/4 X 3/4	1.660	1.071	2	9/16	13/16	--	--
1-1/4 X 1/2	1.660	.859	2	1/2	7/8	--	--
1-1/2 X 1-1/4	1.900	1.682	1	11/16	1-3/8	2-1/2	1
1-1/2 X 1	1.900	1.335	1	5/8	1-5/32	2-1/4	1
1-1/2 X 3/4	1.900	1.071	2	9/16	1	--	--
1-1/2 X 1/2	1.900	.859	2	1/2	1-1/16	--	--
2 X 1-1/2	2.375	1.922	1	3/4	1-17/32	3	1-1/8
2 X 1-1/4	2.375	1.682	2	11/16	15/16	--	--
2 X 1	2.375	1.335	2	5/8	1	--	--
2 X 3/4	2.375	1.071	2	9/16	1-1/16	--	--

[Fitting catalog](#) | [Product catalog](#) | [Request quote/information](#) | [Home](#)

Web site created by Penn Machine. Send questions or comments to [James Friant](mailto:James.Friant@pennmachine.com).