

PRODUCT SPECIFICATION DRAWING

QUICK STAND™ #50-SWHP

Suspended Water Heater Platform

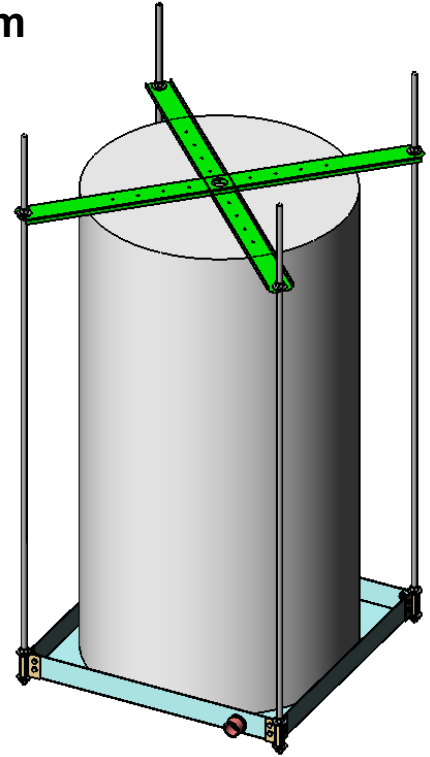
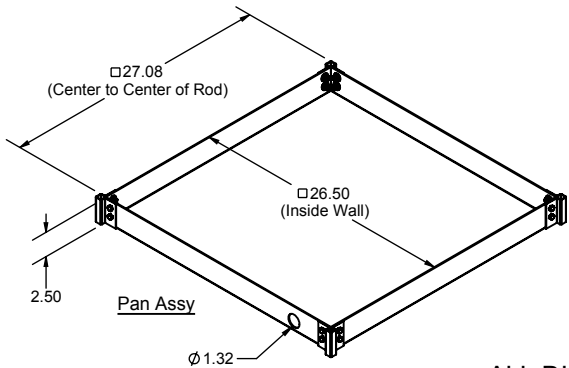

ALL DIMENSIONS IN INCHES

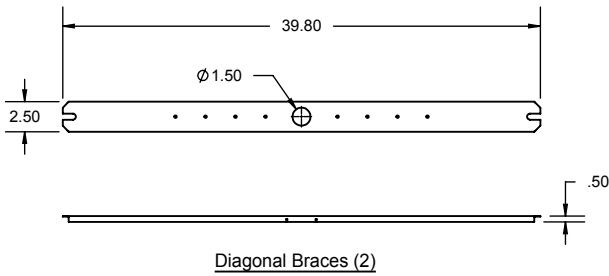

The Suspended Water Heater Platform is engineered to support water heaters up to 50 gallons (up to 600 pounds total weight). This time and labor savings tool is designed for the Professional Contractor. Design features requested by plumbers are incorporated into a professional platform that can be suspended with all thread rod.

Product Information:

- Material:
 - Pan: 12 gage CRS, galvanized
 - Corner Brackets: 14 gage CRS, galvanized
 - Diagonal Braces: 16 gage CRS, galvanized
- Wide platform allows water heaters up to 26-1/2" diameter
- Watertight corners and drain fittings eliminate need for additional drain pan
- Cross-braces (2) two included to capture water heater within the platform
- Static load rating 600 pounds with 2X safety factor (depending on structural anchorage)
- Includes PVC drain body 1" MIPT x 1" FS
- Galvanized steel construction
- Suspends with user supplied 3/8" or 1/2" threaded rod and hardware
- Four corner attachment points allows for seismic/sway bracing connection
- Patent pending

THIS INFORMATION IS PROPRIETARY TO HUBBARD ENTERPRISES AND IS SUBJECT TO CHANGE WITHOUT NOTICE. ANY REPRODUCTION IN PART OR WHOLE WITHOUT THE WRITTEN PERMISSION OF HUBBARD ENTERPRISES IS PROHIBITED.



Product Submittal	
Job Name:	
Date:	
Part Number:	Qty:
Architect / Owner:	
Contractor:	
Notes:	