

# PRODUCT SPECIFICATION DRAWING

## HOLDRITE® Strut Clamp™ #287-P

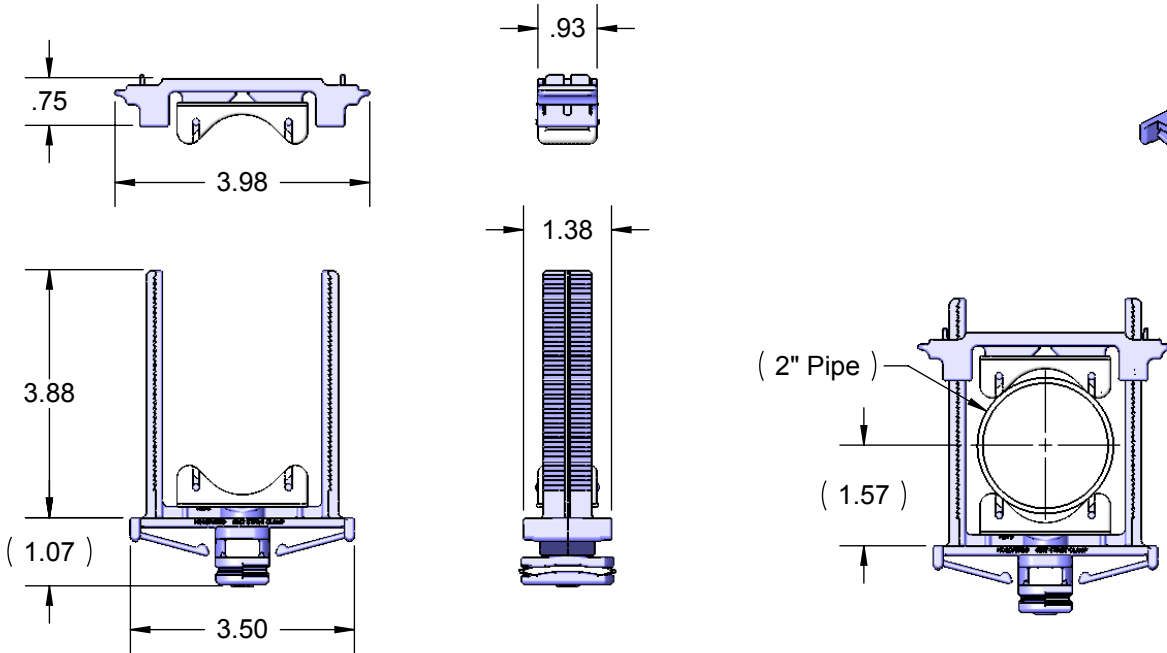
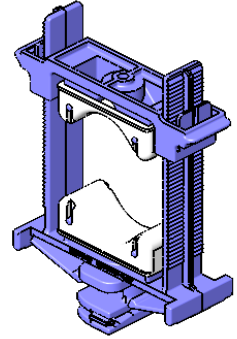

ALL DIMENSIONS IN INCHES

The **HOLDRITE® Acoustical Strut Clamp™ #287-P** is a strong, sound rated variable closure clamp. Two acoustical inserts isolate the pipe from the support structure, reducing piping noise and vibration, while allowing normal pipe expansion and contraction. Clamp supports 1" to 2" CTS/IPS pipe sizes. Supports Copper, PEX, CPVC tubing, conduit, etc. Framework complies with UL94V-2 fire rating.

### Product Information:

- Material:  
 Top & Bottom Clamp: Nylon, medium blue, FR UL94V-2  
 Pads: TPR, natural (off-white), 50 shore A
- Temperature range: -10°F to +180°F
- Load rating: 75 lbs in suspended mode, 300 lbs maximum in top mount
- UPC / IPC / IAPMO listed

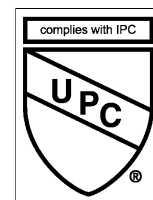

THIS INFORMATION IS PROPRIETARY TO HUBBARD ENTERPRISES AND IS SUBJECT TO CHANGE WITHOUT NOTICE. ANY REPRODUCTION IN PART OR WHOLE WITHOUT THE WRITTEN PERMISSION OF HUBBARD ENTERPRISES IS PROHIBITED.

*.....HUBBARD ENTERPRISES.....*  
**HOLDRITE®**  
*"Converting Makeshift Methods into Engineered Solutions"*

Product Submittal	
Job Name:	
Date:	
Part Number:	Qty:
Architect / Owner:	
Contractor:	
Notes:	