

PRODUCT SPECIFICATION DRAWING

HOLDRITE® Acoustical Standard Clamp™ #255

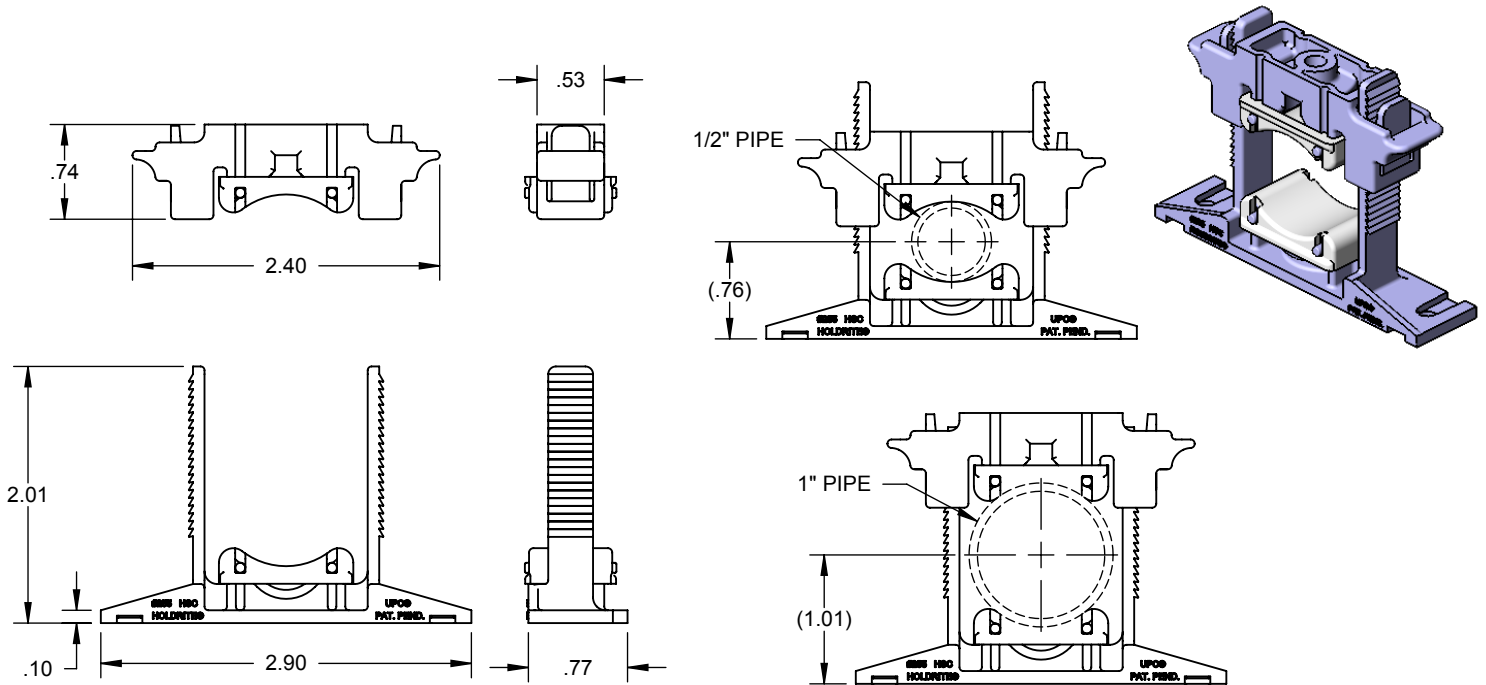

ALL DIMENSIONS IN INCHES

The HOLDRITE® Acoustical Standard Clamp™ #255 is a strong, sound rated variable closure clamp that installs as a standard two hole pipe clamp with one or two screws. Two acoustical inserts insolate the pipe from the support structure, reducng pipng noise and vibration, while allowing normal pipe expansion and contraction. The clamp has a grip strong enough to serve as a stub-out clamp. Clamp supports up to 1" CTS tubing sizes. Supports Copper, PEX, CPVC tubing, conduit, etc. Frame work complies with UL94V-2 fire rating and UPC listed.

Product Information:

- Material:
 Top & Bottom Clamp: Nylon, medium blue, FR UL94V-2
 Pads: TPR, natural (off-white), 50 shore A
- Temperature range: -10 °F to +180 °F
- Load rating: 25 lbs in suspended mode, 200 lbs maximum in top mount
- UPC / IPC listed
- IAPMO listed, per standard PS42-96
- Patent Pending

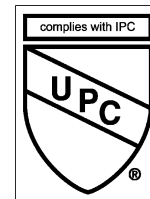

Product Submittal	
Job Name:	
Date:	
Part Number:	Qty:
Architect / Owner:	
Contractor:	
Notes:	

THIS INFORMATION IS PROPRIETARY TO HUBBARD ENTERPRISES AND IS SUBJECT TO CHANGE WITHOUT NOTICE. ANY REPRODUCTION IN PART OR WHOLE WITHOUT THE WRITTEN PERMISSION OF HUBBARD ENTERPRISES IS PROHIBITED.

••••HUBBARD ENTERPRISES••••

HOLDRITE®

"Converting Makeshift Methods into Engineered Solutions"