

PRODUCT SPECIFICATION DRAWING HOLDRITE® #121

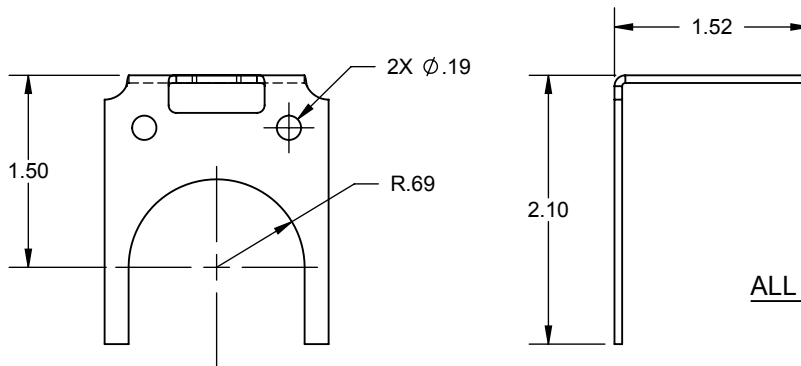
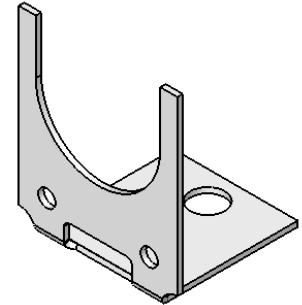
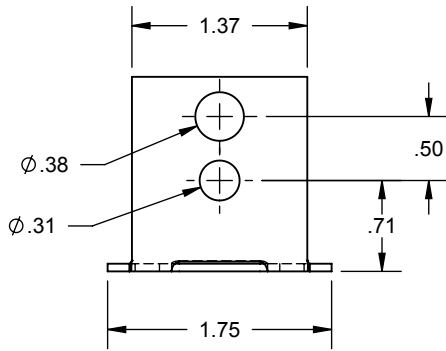

ALL DIMENSIONS IN INCHES

The HOLDRITE® #121 is a 16 gage galvanized steel bracket with an open "U" shape the secures single 1/2", 3/4" and 1" tubing.

Product Information:

- Material: 16 gage CRS, galvanized
- Load rating: 25 pounds
- Supports 1/2", 3/4" and 1" tubing with available inserts
- Available with stainless steel banding from 1" to 5"
- UPC / IPC / IAPMO listed

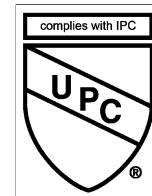

Product Submittal	
Job Name:	
Date:	
Part Number:	Qty:
Architect / Owner:	
Contractor:	
Notes:	

THIS INFORMATION IS PROPRIETARY TO HUBBARD ENTERPRISES AND IS SUBJECT TO CHANGE WITHOUT NOTICE. ANY REPRODUCTION IN PART OR WHOLE WITHOUT THE WRITTEN PERMISSION OF HUBBARD ENTERPRISES IS PROHIBITED.

.....HUBBARD ENTERPRISES.....
HOLDRITE®
 "Converting Makeshift Methods into Engineered Solutions"